

Di-Acro®

OPERATOR'S MANUAL & INSTRUCTIONS

Control-A-Bend CAB-2 for Power Benders

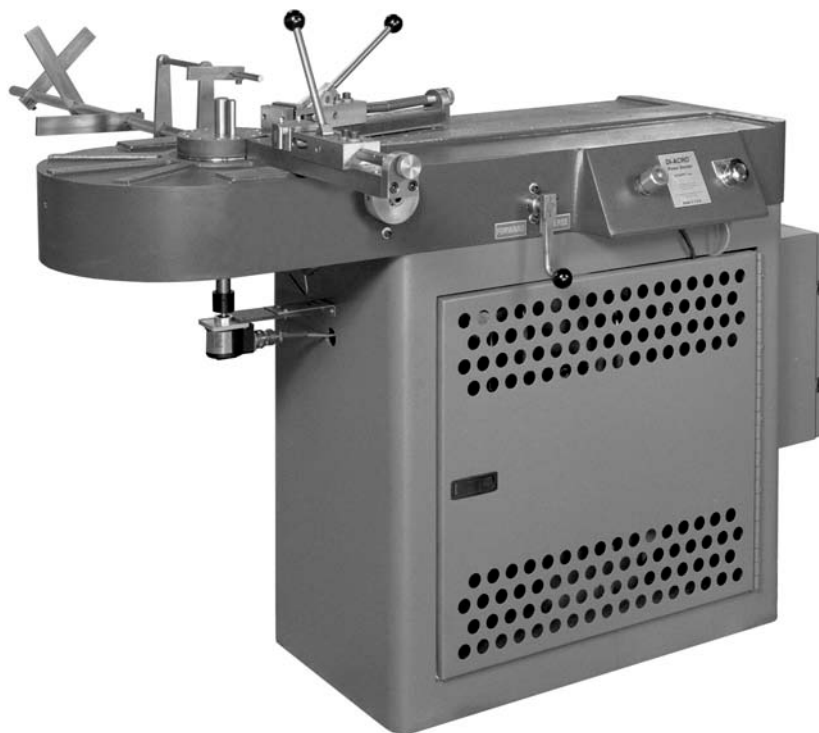

Di-Acro®
METAL FABRICATION EQUIPMENT

579 SCHOMMER DR - STE C
HUDSON, WI 54016

P: 651.342.1756

www.diacro.com

Sale or distribution of this manual is strictly prohibited without the express written consent of Di-Acro.

DISCLAIMER

DI-ACRO by supplying this manual is not liable for any indirect, incidental, or consequential damages or injuries sustained or incurred in connection with using the information in any way contained herein.

DI-ACRO accepts no responsibility or liability resulting from attempts to use this information.

DI-ACRO does not vouch for or warrant the accuracy, completeness or usefulness of any information contained herein.

*** INSTALLATION AND OPERATION INSTRUCTIONS FOR THE CAB-2 ***
(CONTROL-A-BEND Model #2 CNC Control for the Di-Acro Bender)

TABLE OF CONTENTS

INSTALLATION INSTRUCTIONS	A3
OPERATING INSTRUCTIONS	A4
PROGRAMMING	A5
SPRINGBACK TEST	A6
RUN PARTS (Bending)	A7
TROUBLE SHOOTING (Angular Inaccuracies)	A9
SUPPORT ARM INSTALLATION	A10
TRIP ARM SOLENOID MOUNTING INSTRUCTIONS	A11
ENCODER MOUNTING INSTRUCTIONS	A12
TROUBLE SHOOTING (ELECTRICAL PROBLEMS)	A13
ELECTRICAL DIAGRAM	A15

CAUTION

TO PREVENT SERIOUS BODILY INJURY

ALWAYS Keep Fingers, Hands, Arms, Elbows, Head, Feet or other parts of the body clear of swinging arm and out of tooling area while machine is in operation.

*****INSTALLATION INSTRUCTIONS FOR THE CAB-2*****

The CAB-2 (Control-A-Bend Model #2) will allow the user to quickly and accurately produce parts without using the machine's standard Bend Stops. As shipped, your unit is equipped with manual stops to activate the Trip Arm and stop the forming process. Operation of the CAB-2 unit requires installation of a solenoid to activate the Trip Arm and Encoder to monitor Tooling Head positioning. This will eliminate the Bend Stops for this functions. The machine's existing control handles will continue to be used for activation of the specific tooling head.

Read and understand the machine instruction manual before operating the bender. Follow the instructions in this section for installation and explanation of the control operation.

NOTE: Make certain that all electrical power is off before proceeding with installation of CAB-2 control unit.

- 1) SUPPORT ARM INSTALLATION Refer to page 10 for installation.
- 2) Remove the collar and the four (4) Bend Stops that are clamped on the pinion shaft which is located under the bender's nose. With a rag, clean all oil or grease from the shaft.
- 3) TRIP ARM SOLENOID MOUNTING. This step is very important. Please refer to page 11 of this manual for the "TRIP ARM SOLENOID MOUNTING INSTRUCTIONS".
- 4) After installing the Trip Arm Solenoid, the next step is to mount the Encoder. Place two (2) of the Bend Stops back on the pinion shaft and slide them up, out of the way. These will be used later. Please refer to page 12 of this section for the "ENCODER MOUNTING INSTRUCTIONS".
- 5) After installing the Encoder, the next step is to adjust the Bend Stops.

'MAXIMUM TRAVEL' BEND STOP: One Bend Stop should be used as a limit to the Tooling Head's maximum travel. For example: If you are using the #6 Tooling Head, the majority of applications will require less than 180 degrees of rotation. In this case, 185 degrees may be a good place to set the Bend Stop. This will prevent the Rotating arm from colliding with any fixtures or stationary devices which may be affixed to the bender's surface.

'HOME' BEND STOP: The second BEND STOP is used to maintain a constant zero or home for the Tooling Head. To return the Tooling Head, the operator should pull the Control Handle to the return direction, engage and release. The Head will automatically rotate to its Home Position. Providing the bend stop is properly set, the Trip Arm will activate and allow the Tooling Head to come to a rest at the beginning of bend point. It is very important that the Tooling Head components do not collide as this will cause unnecessary wear and tear.



OPERATING INSTRUCTIONS

****OPERATING INSTRUCTIONS****

'CONTROL-A-BEND' is designed to allow the machine operator to program and form required parts while minimizing setup time and reducing scrap. This is achieved through simple part programming, elimination of manual bend stops to achieve desired bend angle(s) and a Springback Calculation routine to quickly attain specific material adjustments. Up to 1000 different part numbers can be stored in memory, each having up to 14 different bend angles.

Before a part can be formed, the control must be programmed. Programs are stored in memory with specific part numbers from 0 to 999. Memory is battery backed. Program information is not lost in a power down condition.

Also, the control can be programmed in decimal format with .1 degree increments. The maximum range for a bend ins 360.0 degrees. If a value greater than this is entered, the control will display the following message:

**Max Angle is 360.0
Any Key Continues . . .**

NOTE: Any time you need to enter or change a value into the controller, you must first press C to 'Clear' the active information.

Helpful Hint: Keep in mind the 'hidden' functionality of the following keys.
They are active in almost every menu:

- A:** Abort (leave current menu)
- C:** Clear (required before a new value can be entered)
- D:** Decimal Point (used on some menus to enter in a '.')
- E:** Enter

All menus are accessible directly via the MASTER MENU. When you turn the Power Switch on, the MASTER MENU will be displayed as follows:

**- MASTER MENU -
A>PGM B> SPRING C>RUN**

All modes of operation are 'menu driven' and virtually self explanatory. To program the control, press the 'A' key on the keypad.

The display will appear as follows:

**- PROGRAM PT# MENU -
Enter Part# : (current part number)**



OPERATING INSTRUCTIONS

You may either accept the current part number by pressing **E** for 'Enter' or you can clear the current value and enter in a new part number (use **C** for 'Clear').

To follow the step by step procedures of this manual, if any number other than on (1) appears as the part number, clear the value by pressing **C**, press **1** and then **E** to enter the value.

The display will appear as follows:

PROGRAM PART# 1
Enter Bend 1: (current value)

We will now program a part with two (2) bends, the first is 90.7 degrees and the second at 60 degrees.

To start, clear the current value by pressing the letter **C** on the keypad. To enter the first bend press **9, 0**, the letter **D** for decimal point, and then **7**.

The display will appear as follows:

PROGRAM PART# 1
Enter Bend 1: 90.7

Press **E** to enter the first bend.

The control will advance to the second bend requirement.

PROGRAM PART# 1
Enter Bend 2: (current value)

Proceed in the same manner as the first bend. Clear any current value and then input **6, 0**, and **E** to enter. Decimal point is not required.

The control should now be at bend three. To finish this part and have the control accept the programmed information, one of two circumstances will apply. If the angle value for bend three is .0, then you may press **E** and the control will advance to the MASTER MENU.

If any value other than .0 appears, then press **C** to clear the value and **E** to complete the program. Once again the the MASTER MENU will appear. The program is now stored.

If you wish to inspect or check the bend angles that have been programmed under a certain part number, you can enter that part number at the PROGRAM PT# MENU and continue to press **E** until the system increments through the bend requirements of the selected program.

NOTE: '**A**' will abort and return you to the MASTER MENU.

If you wish to erase an old part number from memory, you simply program over it with your new bend data.



SPRINGBACK TEST

***** SPRINGBACK TEST *****

One of the most important and useful features of the CAB-2 is the SPRINGBACK TEST function. Used properly, this routine will not only save countless hours of setup time, but also reduce scrap rates that are generally associated with this function. Virtually all material must be overbent to compensate for the materials tendency to return to its original configuration. This will vary from material type (stainless steel, aluminum), configuration (tubing, solid stock) and other variables specific to the application. The required overbend value for many materials is often a percentage of the desired bend angle. This is called the 'proportional' value. However, in certain cases where multiple bend angles are needed a proportional amount may not yield accurate results. Some applications also require a 'constant' value to be added. This control can accommodate both methods.

The SPRINGBACK TEST is a menu driven, self prompting routine. This special menu allows the operator to produce test bends of production material for the selected part requirements. This is accessed from the MASTER MENU by pressing **B** (B>SPRING) on the keypad.

At this time, return to the MASTER MENU of the control and press **B** for the SPRINGBACK TEST feature. The display should appear as follows:

- SPRINGBACK TEST -
Enter Part# : 1

The active part number will be identified. This should be part number 1. Press **E** at this time. The test for a 45 degree bend is now indicated. Make sure that the tooling head is at the home position and that the ARM indication on the display is at .0 degrees. If this is not the case, press **C** to clear the position value. Bend a sample piece of the material for this requirement, remove the part and return tooling head back to the home position. Upon completion, the control will advance to the 90 degree test bend screen. Make a second bend at this time, remove part and return the tooling head to the home position. The control display should look like this:

Enter Test Result OF
45 degree Bend:

Now, measure the results of your 45 degree bend with a protractor and enter this angle in the control as required. Remember, press **C** to clear. Do the same for the 90 degree bend. After entering the results for the second bend a test completed message will appear.

Test Completed . . .
Thanks . . .

The control has now automatically calculated the spring back requirements for this part and stored these values in memory under this number. It is recommended that a spring back test be performed each time the machine is setup for a job, or whenever other variables change.

NOTE: You can bypass the 'constant' calculation routine by ignoring all the 45 degree test and result requirements. Press **E** at the test prompt and enter 0 for angle result.

***** RUN PARTS (BENDING) *****

The Run Mode is accessible only from the MASTER MENU. Any valid programmed part may be entered for operation. If you select a part number that has not been programmed, the following message will appear:

**Bend Not Programmed
Any Key Continues . . .**

Locate the MASTER MENU display and press C. You are now in the Run Part # Menu. Press E if the identified part number is correct, otherwise press C to clear selection. Input the required part number and press E. In order that you may follow along with this manual, make sure that part number 1 is active. Prior to pressing E, the display screen should look like this following:

**- RUN PART# MENU -
Enter Part# : 1**

Whenever you are in the Run Mode, the following screen will be displayed indicating the programmed angles for the various required bend of the active part:

**BEND 1 -ARM- -CNT-
90.7 .0 0**

The bend number indicates the next bend that will be performed. If more than one bend is programmed for the current part, the control will automatically increment to the next number after each bend is completed. To review, advance or skip a specific bend in a multiple bend part, you may use the **F** key to advance forward or **B** to move backward within the program. With this feature, the controller can be re-started at any desired bend number.

The -ARM- section displays the current position of the tooling head (encoder count). This value should be .0 whenever the tooling head is at the home position. The encoder count can be cleared to .0 after a part number has been selected and the control indicated the BEND, ARM, CNT display area of the Run Part# Menu. Simply press **C** to activate the following display:

**D> CLEAR ENCODER
E> CLEAR PART COUNTER**

Now, Press D to clear the encoder and zero the count.

NOTE: At power up of the unit, the control will automatically zero out the encoder. If the tooling head is not at the home position when this occurs, it will be necessary to return the tooling head and press **C** to clear (reset) the encoder.

The -CNT- section displays the current Parts Counter value. The operator may clear or zero this value by pressing **C**, and the **E** (CLEAR PART COUNTER)

The operator may abort the Run Part# Menu by pressing the **A** key

RUN MODE: To run or bend a part that has been programmed, locate the MASTER MENU and select RUM MODE by pressing C. The display will change to the RUN PART # MENU. You may use the active part number or press C to clear the value and then enter in the required part number followed by pressing the E key for enter. Once again, for the purpose of using this manual, make sure that part number 1 is active. The display should look like this:

**BEND 1 -ARM- -CNT-
90.7 .0 0**

In the sample program, Bend #1 was programmed for 90.7 degrees. The ARM position should be .0 degrees and at the home position. If the tooling head is not in the home position and/or the ARM position is not .0, position head accordingly and clear any value indicated in the ARM area of the display. The ARM position is cleared by pressing C and then D (Clear Encoder).

The machine is now ready to produce Bend #1. The operator simply positions and clamps the material into the tooling head, activates the control lever in the required direction, engages level and then releases it. ALWAYS RELEASE THE CONTROL LEVER IMMEDIATELY AFTER IT HAS BEEN ENGAGED. The tooling head will rotate until it reaches the programmed degree of bend. Keep in mind that the tooling head may rotate further than the programmed bend angle due to Springback requirements.

Upon reaching the angle requirements. The Trip Arm Solenoid will be energized, thus stopping the tooling head. After the material is removed, the Control lever should be pulled in the opposite direction, engaged and quickly released. If the 'HOME' Safety Bend stop is properly adjusted, the Bend Arm will come to a rest at the 'HOME' position. The display should read .0 degrees when the Bend Arm is HOME. If the display does not read .0 degrees then press C for Clear. If the display continues to read something other than .0 degrees whenever the Arm is returned home, then most likely the Bend Arm is overshooting the home position, thus causing interference to the controller. IT IS ALSO IMPORTANT TO RELEASE YOUR HAND FROM THE CONTROL LEVER AFTER PULLING IT TO THE REVERSE DIRECTION.

When the tooling head returns home, the controller will search to see if a second Bend is programmed. If a second Bend is programmed, as in the case of our sample, then the controller will increment and display the requirements as follows:

**BEND 2 -ARM- -CNT-
60.0 .0 0**

You may at this point continue to BEND #2 or if for some reason you need to go back to Bend #1 or even go up to another BEND #, then use the 'F' or 'B' keys. F means FORWARD and B means BACKWARD. This feature simply allows the operator to jump in and start at any BEND# that he or she desires. This feature also allows you to inspect every Bend programmed before you run the part. The F/B keys are only active while in the Run Mode.

To exit the RUN MODE, press A for abort and the controller will return back to the MASTER MENU.



****TROUBLE SHOOTING****

CAUSES FOR ANGULAR INNACCURACIES:

- 1) OPERATOR did not immediately let go of the control lever after engaging it forward to make a bend. If you do not let go of the control lever while the machine is bending, you may actually interfere with the controller's attempt to stop the tooling head.
- 2) OPERATOR did not immediately let go of the control lever after pulling it backward to return to HOME. If you do not let go of the control lever while the Head is returning to HOME, you may experience an overshoot of the HOME position causing a collision and/or excessive machine vibration. Excessive machine vibration can cause the control's CURRENT COUNT to be inaccurate. Once again, the CURRENT COUNT should always read .0 degrees when the tooling head is at the HOME position.
- 3) 'HOME' BEND STOP not properly adjusted. (See INSTALLATION INSTRUCTIONS)
- 4) 'TRIP ARM SOLENOID' not properly installed. (See TRIP ARM SOLENOID MOUNTING INSTRUCTIONS).
- 5) ENCODER not properly connected to the control or to the machine. (See ENCODER MOUNTING INSTRUCTIONS).
- 6) CLAMP BLOCK IS SLIPPING. If the Clamp Block is not tight enough, the material being bent will slip and flow into the bend area. An 'uncontrolled' flow as such can actually cause angular inaccuracies because the flow isn't consistent. (Also, tubing applications may wrinkle because of slipping.)
- 7) PRESSURE FROM FOLLOW BLOCK IS NOT CONSISTENT. Make sure that your Follow Block (pressure die) is always in the same position while you are clamping up on the tube for each bend. A Follow Block that is misaligned while being 'advanced' into the tube can actually bend the tube before the Bend Arm even Rotates!
- 8) BENDING SPEED OR PRESSURE IS INCONSISTENT. Make sure that your Flow Control setting for the bend speed is recorded for each set-up and continue to use the same setting each time you run a certain job. The same applies to the pressure setting.

The tooling head speed must be consistent for good repeatability.

IMPORTANT NOTE: ADHERE TO AND FOLLOW ALL PRECAUTIONS LISTED IN THE DI-ACRO POWER BENDER MANUAL!!!

***** SUPPORT ARM INSTALLATION *****

A) **DISCONNECT ALL POWER TO THE MACHINE.**

B) Open door on the electrical disconnect box. Two holes will be drilled in the top. Make sure that you protect the internal components from any chips that may possibly work inside the box.

C) Locate control support arm and position it according to the diagram below.

D) Mark the location of the two holes required for mounting.

E) Drill two holes at .265" diameter. Once again protect the inside of the box from metal chips during the drilling process.

F) Mount the support arm with the hardware supplied. Close electrical disconnect box door.

G) Locate the CNC Control, open the front cover of the unit and attach to the support arm with hardware supplied. Close and secure front cover of the control.

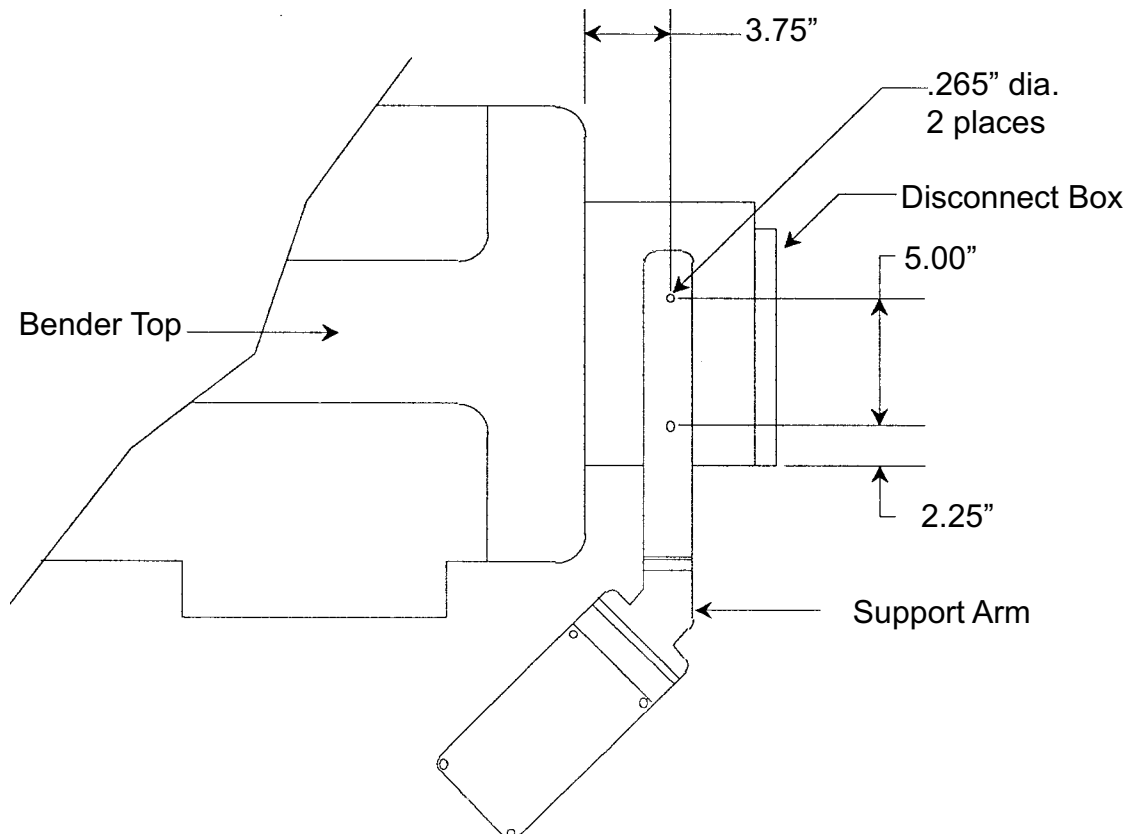

***** TRIP ARM SOLENOID MOUNTING INSTRUCTIONS *****

- A) Loosen TRIP ARM CLAMP and allow TRIP ARM to drop free.
- B) Position SOLENOID BRACKET over Bender's Casting and tighten the two capscrews.
- C) Position TRIP ARM between the cutout in the Solenoid Bracket (DO NOT TIGHTEN TRIP ARM CLAMP YET....)
- D) Allow SOLENOID PLUNGER to drop around the TRIP ARM (Use the Metal Strip located at the end of the PLUNGER to secure the TRIP ARM to the SOLENOID PLUNGER).
- E) With the TRIP ARM attached to the PLUNGER, push the PLUNGER up until the TRIP ARM is about 1 inch from the Bender's Casting; Rotate CONTROL ROD counter clockwise as far as you can; Tighten TRIP ARM CLAMP. (CHECK AND MAKE SURE THAT THERE IS ABOUT 1 INCH BETWEEN THE TRIP ARM AND THE BENDER'S CASTING!)
- F) Manually push the PLUNGER up and make sure that it 'bottoms out' in the SOLENOID without any interference. The PLUNGER must 'bottom out' when the SOLENOID is energized to prevent 'CHATTERING'.
- G) Make sure that the TRIP ARM can move up and down without any interference or binding (this is important!).
- H) Connect Solenoid cable to the control.

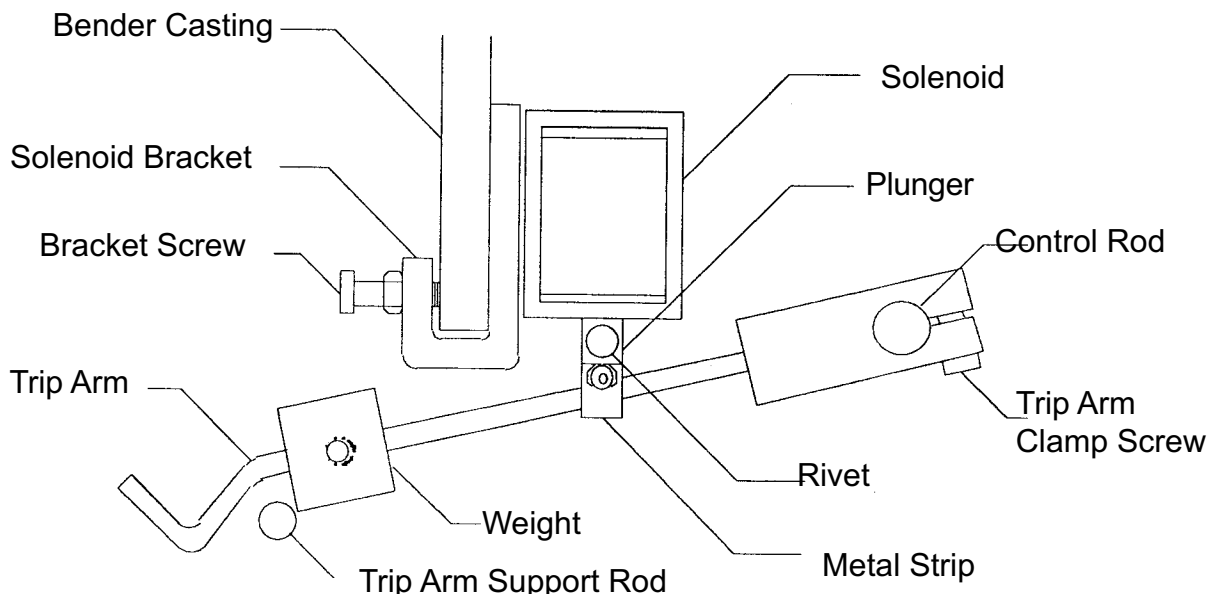

**** ENCODER MOUNTING INSTRUCTIONS****

- A) Remove the two lower screws and nuts from ANGLE BRACKET. Loosen the two upper screws on CONNECTING BRACKET.
- B) With the Encoder assembly intact, Slide the Encoder COUPLING over the Bender's Drive Shaft and secure it with the two set screws.
- C) The Encoder's weight is supported by the ENCODER COUPLING. The CONNECTING BRACKET is designed to prevent the ENCODER from rotating.

Place a level on the CONNECTING BRACKET and level it. Use a center punch to mark two holes on the bender's surface through the two lower holes existing in the ANGLE BRACKET. Drill two .169" diameter holes through the bender's surface. (.169" is a number 18 drill). Re-install and tighten the two lower screws and nuts on the ANGLE BRACKET (connecting it to the bender).

NOTE: MAKE SURE THE CONNECTING BRACKET IS LEVEL...

Now, tighten the two screws and nuts between the CONNECTING and ANGLE BRACKETS.

- D) Connect Encoder cable to control.

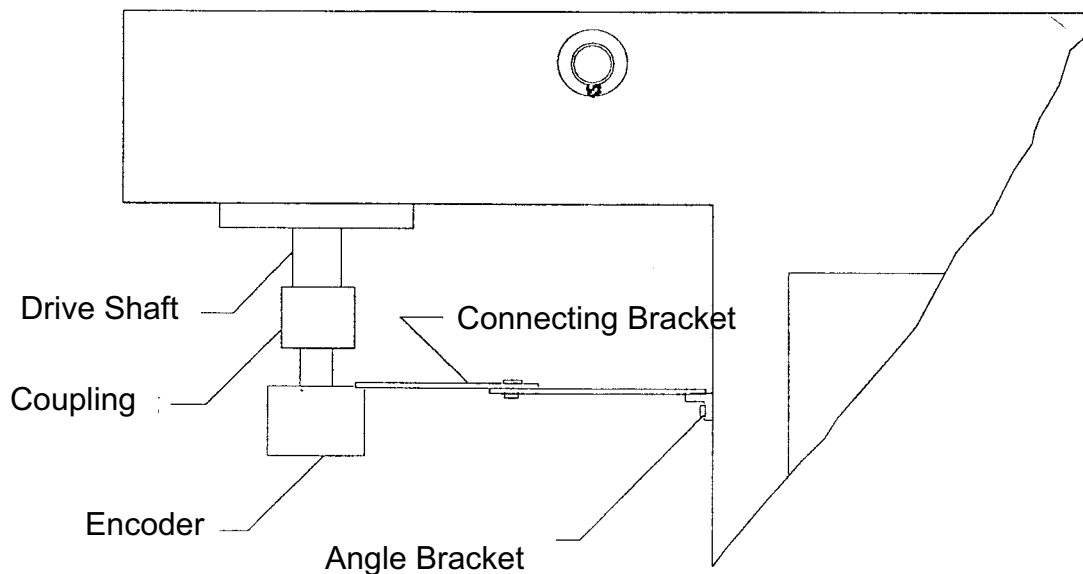



ELECTRICAL TROUBLE SHOOTING

**** TROUBLE SHOOTING FOR ELECTRICAL PROBLEMS ****

WARNING: ALL ELECTRICAL TROUBLE SHOOTING MUST BE DONE BY QUALIFIED PERSONNEL ONLY.

PROBLEM

SOLUTIONS

No Display

- 1) Check for a physically damaged display.
- 2) Check to make certain that the display cable is not loose
- 3) Check the 1AMP fuse in the fuse holder which is located in the 'Power Entry' module on the controller's, side. The power entry module also houses the power switch.
- 4) Check the output of the 5V DC power supply which is located in the controller.
- 5) Replace Display.

Only some of the display dots are illuminated:

- 1) Replace the display

Display works, but the 'Current Count' is not illuminated.
(no zeros, no characters):

- 1) Check encoder.
- 2) Check encoder cable.

Display works, but the keys you press are not displayed:

- 1) Check keypad cable, make certain it is not loose.
- 2) If any of the keys on the keypad are damaged, or have lost their 'Tactile' feedback while depressing them, then replace the keypad. The keypad is easily removed by using a razor blade to peel up one corner and then gently pulling the unit from the control cabinet.

Memory is lost when power is removed:

Replace battery backed ram chip #DS1220 on the CPU card

Bend arm does not stop and 'Current Count' appears to be correctly updated:

- 1) Trip arm solenoid may not be properly mounted or adjusted. Refer to the instructions in this manual.
- 2) Trip arm solenoid plunger may be causing binding or interference with the bender's trip arm. Refer to the instructions in this manual
- 3) Metal strip on solenoid plunger may need to be replaced if it is worn or torn.
- 4) Make certain that you release the bender's control handle immediately after moving it forward or backwards.
- 5) If bender's control handle is 'Locked' in one position, then check for a misaligned control rod assembly.
- 6) Check the solid state relay which is mounted inside the control cabinet

Bend arm does not stop and 'Current Count' is illuminated but remains unchanged:

- 1) Check encoder.
- 2) Check encoder cable.

Input fuse keeps blowing:

- 1) The solenoid plunger may be too far out of the solenoid body. Re-adjust solenoid mounting as per the instructions in this manual.
- 2) Make certain that you are using a 1 AMP fuse only.

***** ELECTRICAL DIAGRAM *****

