

SET-UP AND ADJUSTMENT OF THE DI-ACRO QUIK-LOK

In order to provide sufficient clamping pressure for bending with a Quik-Lok, it must be set up properly. Failure to follow these instructions may result in poor performance from your Di-Acro bender.

NOTE: Read the entire procedure prior to setting up the Quik-Lok. A Model 2 bender is shown throughout this procedure. All other Quik-Lok assemblies will be set up in the same manner.

1. Place the desired radius collar on your bender, and mount the Quik-Lok assembly so that the clamp block is parallel with the flat side of the radius collar, as shown in Figure 1, below. Leave the bolts slightly loose for now.

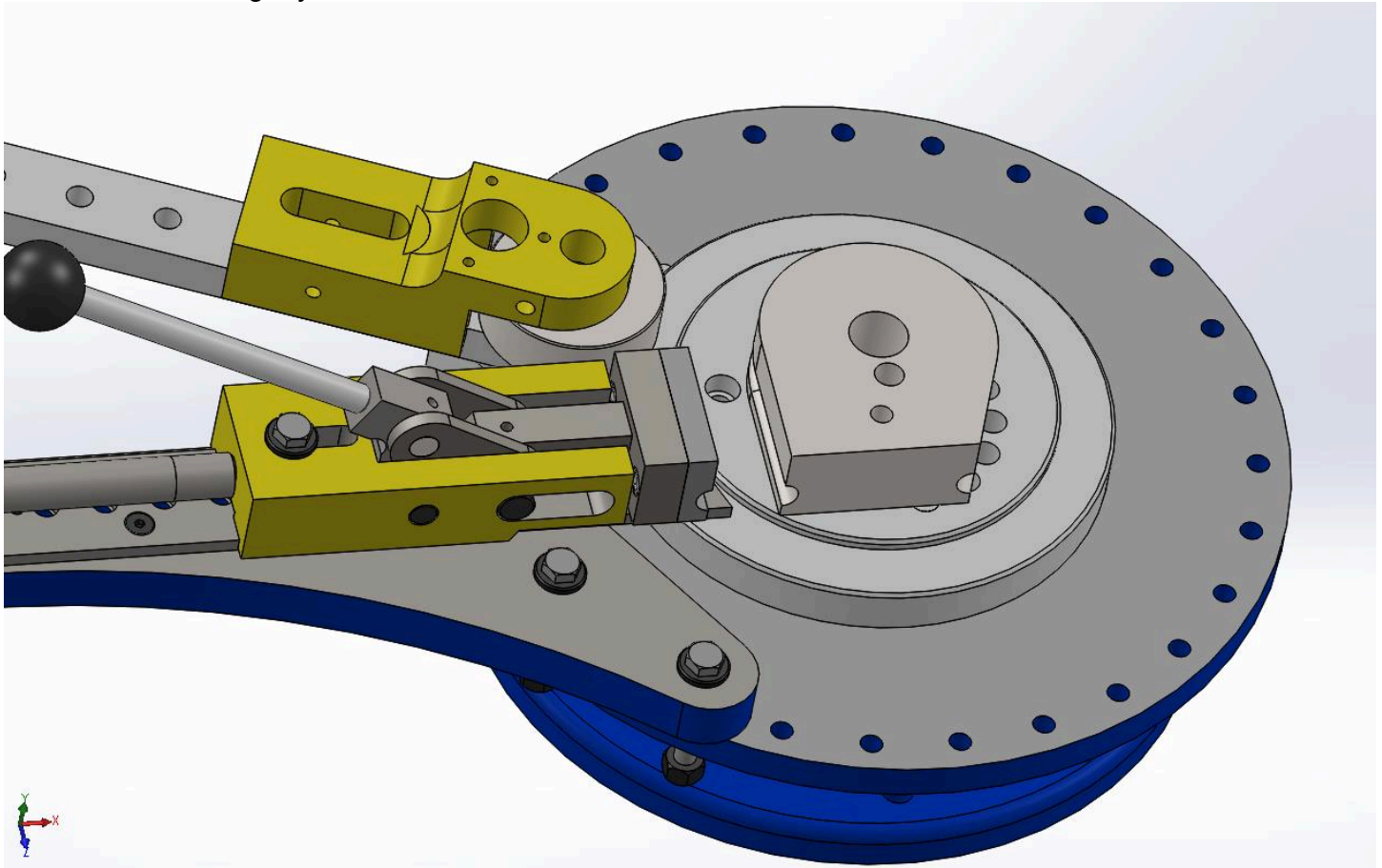

Figure 1: Proper Quik-Lok placement

2. With the Clamp Block that corresponds to the radius collar installed onto the Quik-Lok, Index the handle rod forward, as shown in Figure 2.

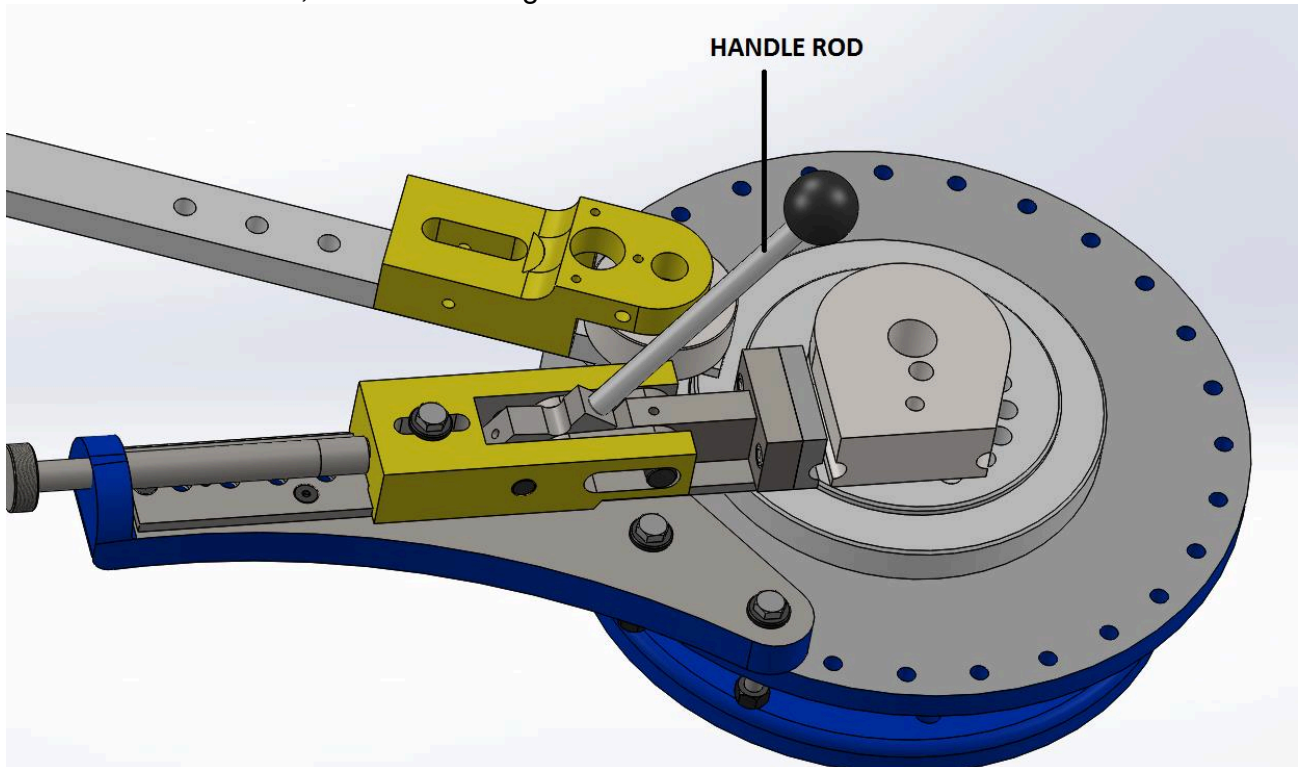

Figure 2: Handle Rod in the Forward, or Clamped, position

3. Loosen the hold-down bolt on the hanger, and adjust the knurl head screw in or out until the clamp block touches the radius collar. Note that you may need to change the spacer rods and/or move the hold-down bolt to another hole in the Quik-Lok base to achieve this position. Tighten the knurl head screw until it becomes hard to turn. Tighten the bolts for the Quik-Lok base and the hold down bolt in the hanger at this time.

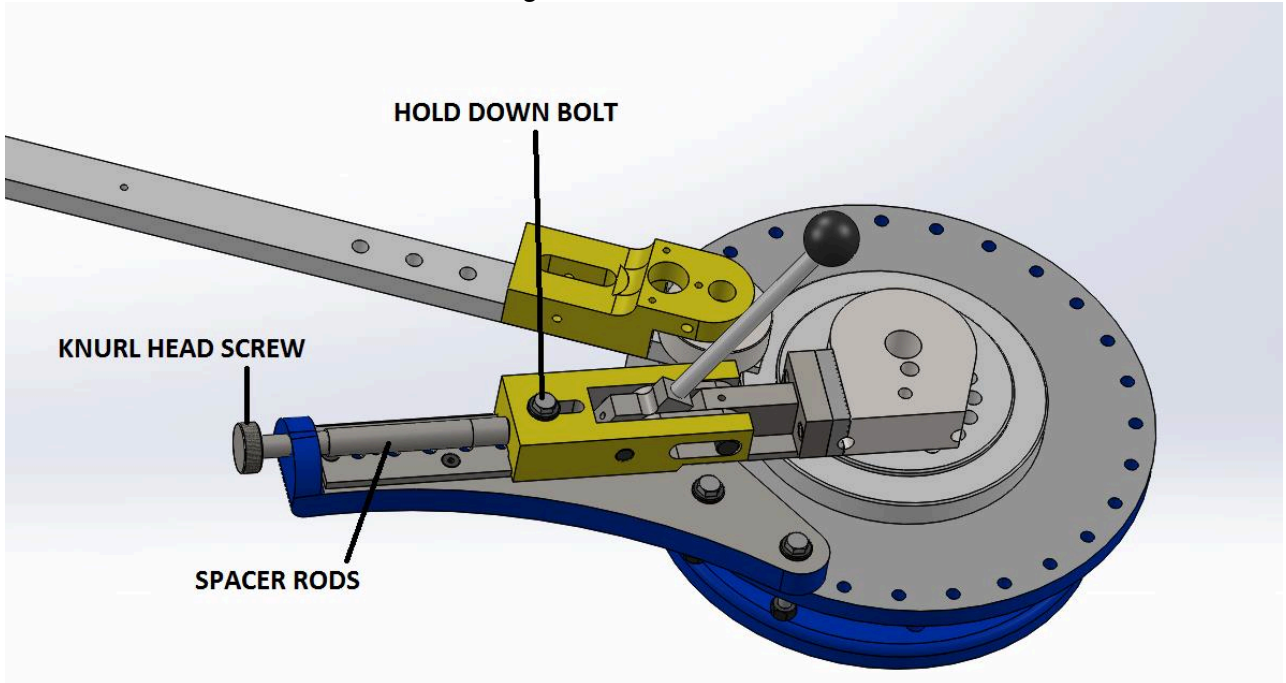

Figure 3: Clamping pressure adjustment

The Quik-Lok is now adjusted properly for Di-Acro tooling. Unclamp the Quik-Lok by indexing the Handle Rod away from the bender. Now adjust the forming nose or roller and start bending!