

HAND SHEARS OPERATIONS MANUAL

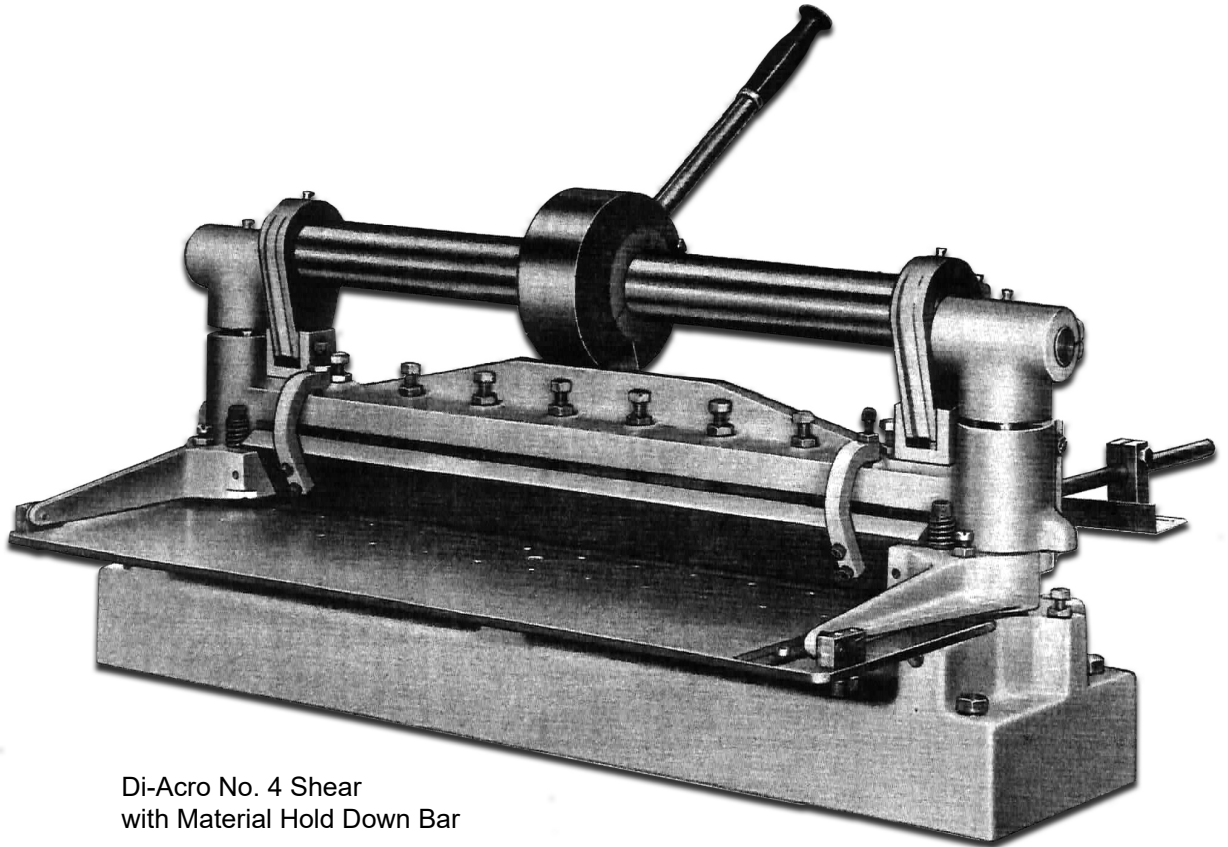

Di-Acro No. 4 Shear
with Material Hold Down Bar

Di-Acro[®]

METAL FABRICATION EQUIPMENT

579 SCHOMMER DR - STE C

HUDSON, WI 54016

(651) 342-1756 (P)

OBSOLETE MACHINE

MANUAL DISCLAIMER

DI-ACRO by supplying this manual is not liable for any indirect, incidental, or consequential damages or injuries sustained or incurred in connection with using the information in any way contained herein.

DI-ACRO accepts no responsibility or liability resulting from attempts to use this information.

DI-ACRO does not vouch for or warrant the accuracy, completeness or usefulness of any information contained herein.

Hand Operated Shears

Cutting speed with these machines on certain operations rivals that of the power operated shears. Manually operated Di-Acro shears are compact and easily operated by anyone. Blades are made of alloy tool steel, properly hardened and precision ground.

Specifications and Capacities

Di-Acro Hand Operated Shears	No. 1	No. 2	No. 3	No. 4
Maximum Shearing Width	6"	9"	12"	24"
Material Capacity – Sheet Steel	16 gauge	16 gauge	16 gauge	16 gauge
Net Weight	35 lbs.	80 lbs.	150 lbs.	275 lbs.

Accessory Equipment

High Carbon-High Chrome Blades are available for all models. They are especially recommended when cutting stainless steel, monel and high silicon-high alloy sheets.

A Spring Charged Material Hold Down Bar, for hand operated Shears No. 3 and No. 4, eliminates slippage when shearing heavy materials, It is recommended for use whenever extreme precision is required.

Shear Stand - available for all Models. Made of heavy gauge steel, finished in machine tool gray. Thirty-three inches high.

"Quik-Set" Micrometer Gauges - available as an accessory for all hand operated Di-Acro Shears. Makes fast, accurate gauging possible for shearing to close tolerance. Rods are 12 3/4" long, gauges have graduations of .001" and one complete turn moves assembly 1/10". By depressing Micrometer Gauges, assembly can be moved to any position on rods for squaring and can be angled for special shearing jobs.

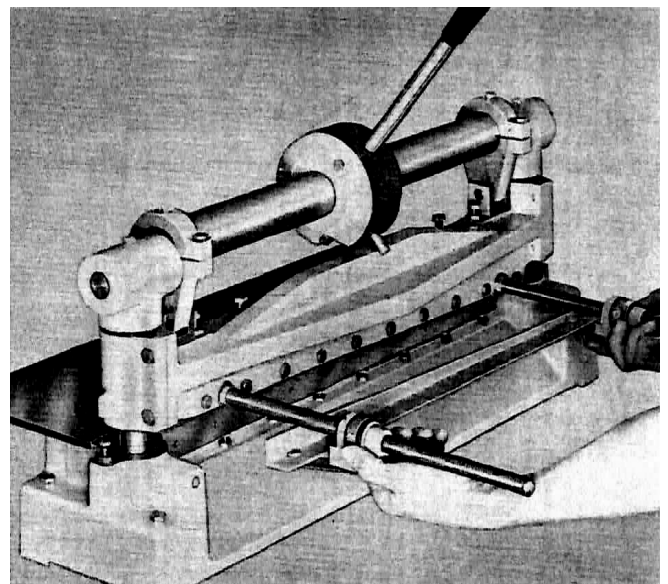

The Di-Acro Shear is shipped partially "knocked down" for convenience in handling. To set it up for operation, follow this suggested procedure:

1. Insert the handle in the holder and tighten it in place.
2. Mount the shear table on the base casting with the table screws provided for this purpose.
3. Mount the protractor gauge on the table with the gauge screws.
4. mount the proper material gauge on the shear as outlined under point two in the section titled "Operating Instructions on page 4.
5. Bolt the shear to a flat surface such as a rigid table or bench stand. Shim if necessary to assure level mounting. Four holes are provided in the base casting for mounting purposes. The smaller model Shears can also be vise mounted.

Slitting and Notching with Hand Operated Shears

Because the top shear blade of all manually operated Shears is set at an angle, it is possible to perform slitting and notching operations. This is accomplished by adjusting the Stop Bolts and properly locating the protractor gauge so that the shearing action is stopped at the desired point.

When slitting or notching heavy material, the work may be marked beyond the actual point of shearing. To minimize work marking, the angle or pitch of the top shear blade can be increased by loosening the blade mounting bolts and adjusting the blade support bolts.

If work marking cannot be tolerated, grind a small notch in the cutting edge of the top shear blade at the point where you want the shearing action to stop.

CAUTION

Do not grind across the entire surface of the shear blade, as you will also notch the opposite cutting edge. Both top and bottom blades have four cutting edges. The blades are interchangeable and reversible in every direction. It is therefore possible to grind six cutting edges of these blades for notching operations and still retain two un-notched edges for ordinary shearing operations. An exception to this are the blades for the No. 1 and No. 2 shears. Because of a difference in size, each of them has but two cutting edges.

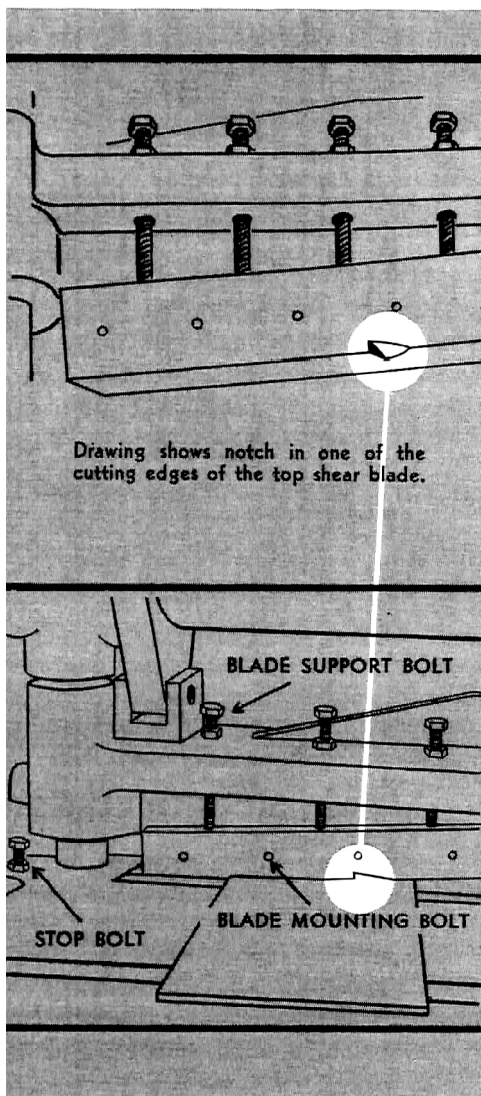

Operating Procedures for all Di-Acro Shears are the same as listed below except for gauging instructions. Power Shears are equipped with "Quik-Set" Micrometer Gauges. See page 6 for instructions on "Quik-Set" Micrometer Gauges.

When Setting up a Di-Acro Shear for production run, follow these suggested procedures:

1. Mount the ruled squaring gauge or the protractor gauge to the most practical position on the work table and adjust it to the desired angle. In the event a square cut is required, one edge of a precision square should be placed against the top shear blade. The other edge can then be used for accurately adjusting the Squaring Gauge.
2. Mount and position the proper material gauge. Two gauges are supplied with each shear. The one material length gauge is for use when gauging longer lengths of material. It is quickly mounted on the front of the shear for the accurate trimming of parts or on the back of the shear for precision sizing of stock.

An additional rear gauge is provided which can be adjusted inward to the very edge of the lower blade allowing extremely narrow strips to be precisely duplicated. Fine adjustment is accomplished through the use of an additional set of gauge blocks with socket screws which are mounted behind the regular gauge blocks. Here is an example of how this adjustment is made:

The operator first sets the regular gauge blocks for the approximate length of cut. Then he positions the fine adjustment blocks about one-half inch behind them. Upon test shearing a piece of material he finds from a micrometer reading that he is .030" over (or under) the desired length. The socket screws in the fine adjustment blocks are one inch long and have 16 threads to the inch. One complete turn of each of these screws therefore moves the gauge 1/16 of an inch or 0.62". To compensate for a .030" difference in the length of the material, the operator makes approximately a one-half turn for both socket screws.

The gauges can also be set at an angle if it is desirable to gauge material that way. To Operate the shear all that is necessary is to:

- A. Place the material on the work table, gauge it.
- B. Perform the shearing operation.
- C. Advance the material and repeat the cycle.

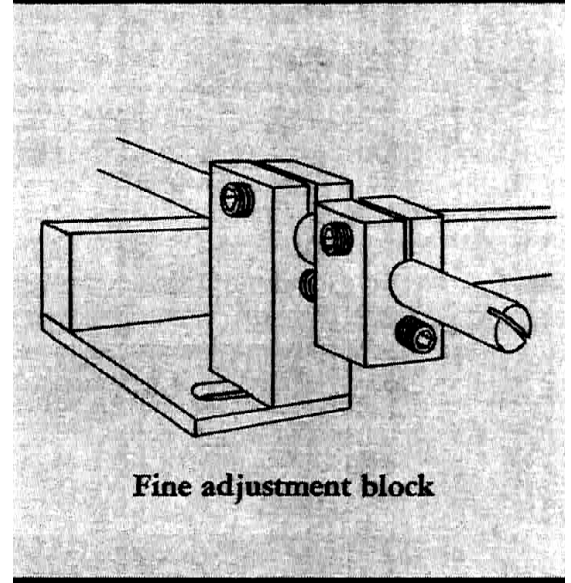
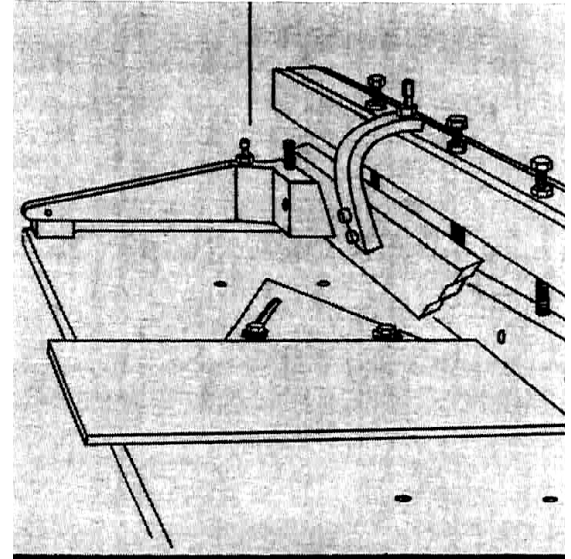

Fine adjustment block

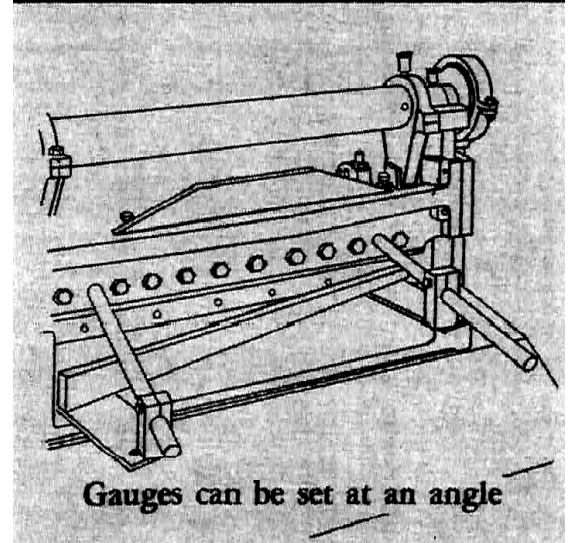

Gauges can be set at an angle

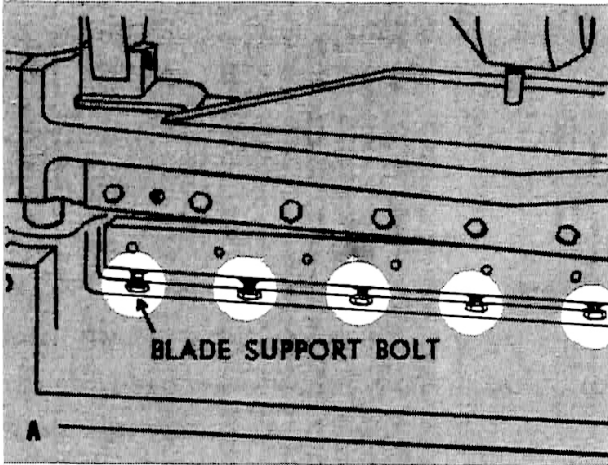

The precision standards to which Di-Acro Shears are built eliminate the necessity of adjusting the shear blades after they have been bolted into position against the based and top blade castings.

When shipped from the factory, these machines are adjusted to accurately shear 16 gauge steel and the thinnest of sheet materials. Should a finer adjustment become necessary, it can be obtained by placing a shim between the bottom blade casting and the shear blade.

The bottom shear blade should at all times be located so that its upper edge is flush with the top of the base casting and shear table.

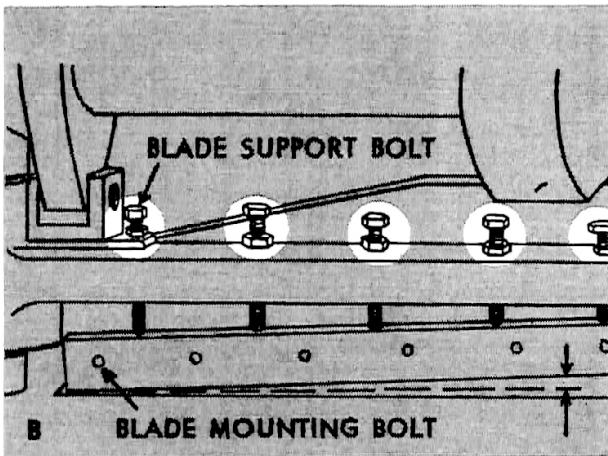

Vertical adjustment of the bottom shear blade is obtained by use of the blade support bolts which are locating in the base casting directly below the bottom blade (illustration A).

The angle of pitch of the top shear blade can be increased or decreased by loosening the blade mounting bolts, and adjusting the blade support bolts. After this adjustment has been made, the blade mounting bolts and the lock nuts on the blade support bolts should be tightened (illustration B).

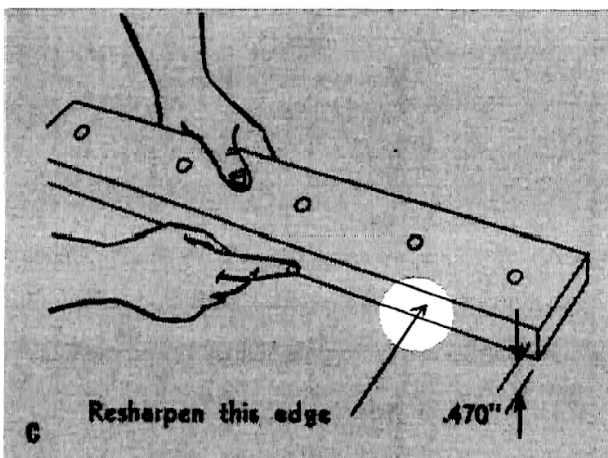

Di-Acro Shear blades are made from high quality, oil hardened tool steel properly heat treated and precision ground. They are easily resharpened on an ordinary surface grinder by merely grinding the narrow edge of the blade which measures .470 inches.

CAUTION

Do not grind the wide surface of the blade as this will reduce the size and necessitate shimming to obtain proper adjustment.

"Quik-Set" Micrometer Gauges are shipped from the factory installed on Power Shears. To install "Quik-Set" Micrometer Gauges on Handle Models or Power models already in the field, follow the procedures listed below:

Installation:

1. Remove old material gauge and bearing rods from shear.
2. Mount Material Stop C on Micrometer Gauge E.
3. Screw in Threaded Rods A and B by hand until they stop. Make sure lock nuts are loose.
4. Synchronize gauges.

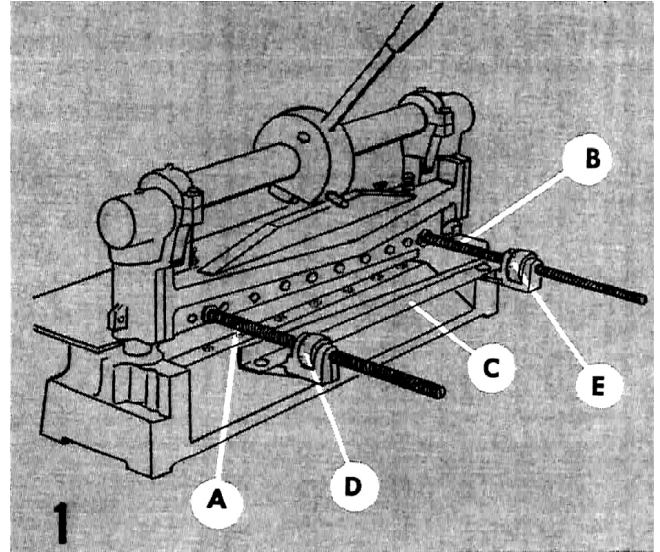

Adjusting "Quik-Set" Micrometer Gauges:

Operator can easily and quickly adjust Gauges while standing either in front or back of Shear. To adjust:

1. Set both Micrometer Gauges on zero and push down or depress. This releases the Material Stop Assembly from the threaded rods.
2. Move Material Stop to approximate desired location (complete assembly can be freely moved back and forth on threaded rods when Micrometer Gauges are depressed) and adjust Micrometer Gauges to accurately position Material Stop.

To Synchronize Gauges:

- A. Set Micrometer Gauges D and E on zero.
- B. Push down or depress spring loaded Micrometer Gauges to release them from Threaded Rods and slide Material Stop Assembly forward to approximately 1/2" from the lower shear blade.
- C. Turn Micrometer Gauges D and E back and forth to engage Threaded Rods
- D. Turn Micrometer Gauges D and E clockwise until material Stop C touches lower shear blade then back off Micrometer Gauges to zero.
- E. Turn Threaded Rods A and B counter clock-wise* until material Stop C touches lower shear blade on each end. Tighten lock nut on Threaded Rods.

*Note: It is important that both threaded rods are adjusted at the same time to accurately synchronize the Micrometer Gauges.

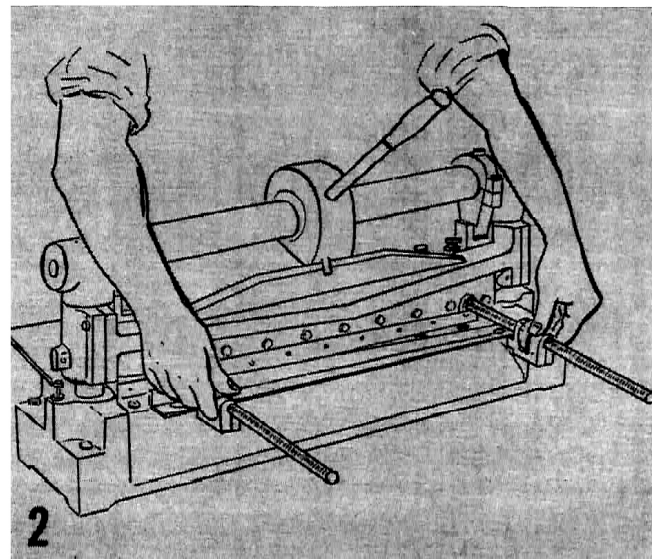

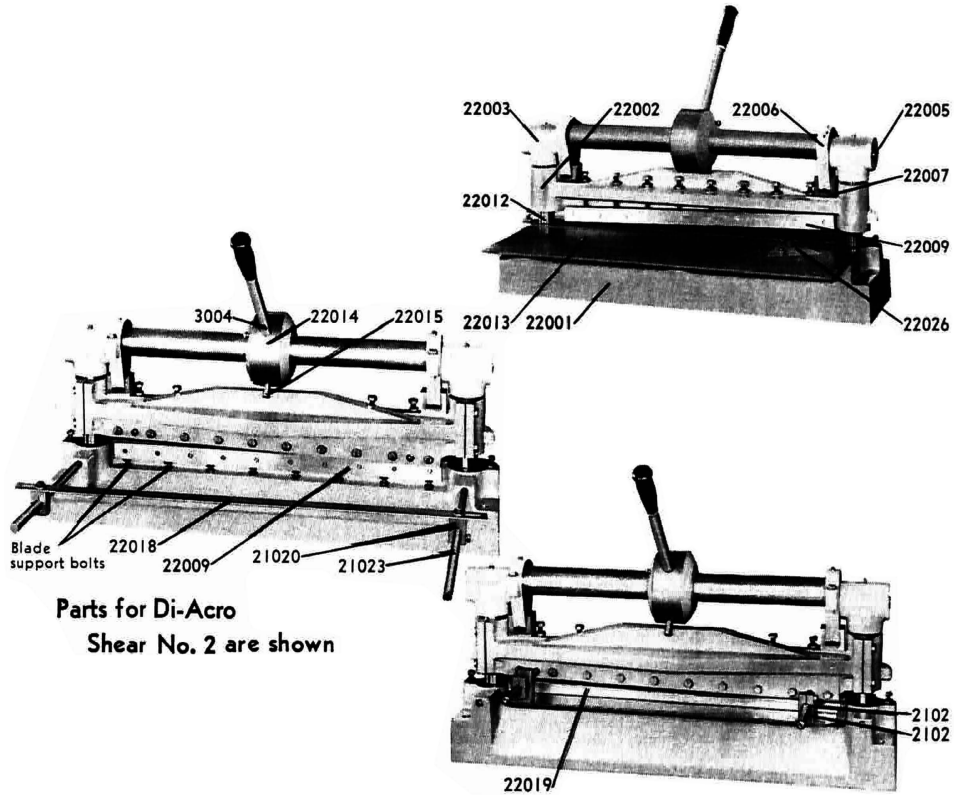

Parts for Di-Acro
Shear No. 2 are shown

Description	No. 1	No. 2	No. 3	No. 4
Base	21001	22001	23001	24001
Blade Casting	21002	22002	23002	24002
Shaft Bearings (2)	21003	22003	23003	23003
Shaft	21005	22005	23005	24005
Shaft Links	21006	22006	23006	24006
U Links	21007	22007	23007	23007
Blades	21009	22009	23009	24009
Posts (2)	21012	22012	23012	24012
Table	21013	22013	23013	24013
Handle Holder	21014	22014	23014	24014
Handle Stop Bolt	21015	22015	23015	24015
Handle Arm Long			3005	3005
Handle Arm Short	21017	3004	8004	8004
Material Stop Lower	21018	22018	23018	24018
Material Stop Upper	21019	22019	23019	24019
Material Stop Clamp A	21020	21020	33015	33015
Material Stop Clamp B	21021	21021	23021	23021
Material Stop Clamp C				24022
Fine Adjustment Stop	21077	21007	25007	25007
Lower Rod	21023	21023	33017	33017
Upper Rod	21024	21024	33553	33553
Protractor Gauge	21026	22026	23026	23026
Squaring Gauge (not shown)	21084	21084	25084	25084