

OPERATOR'S MANUAL & INSTRUCTIONS

MODEL 48 POWER SHEAR

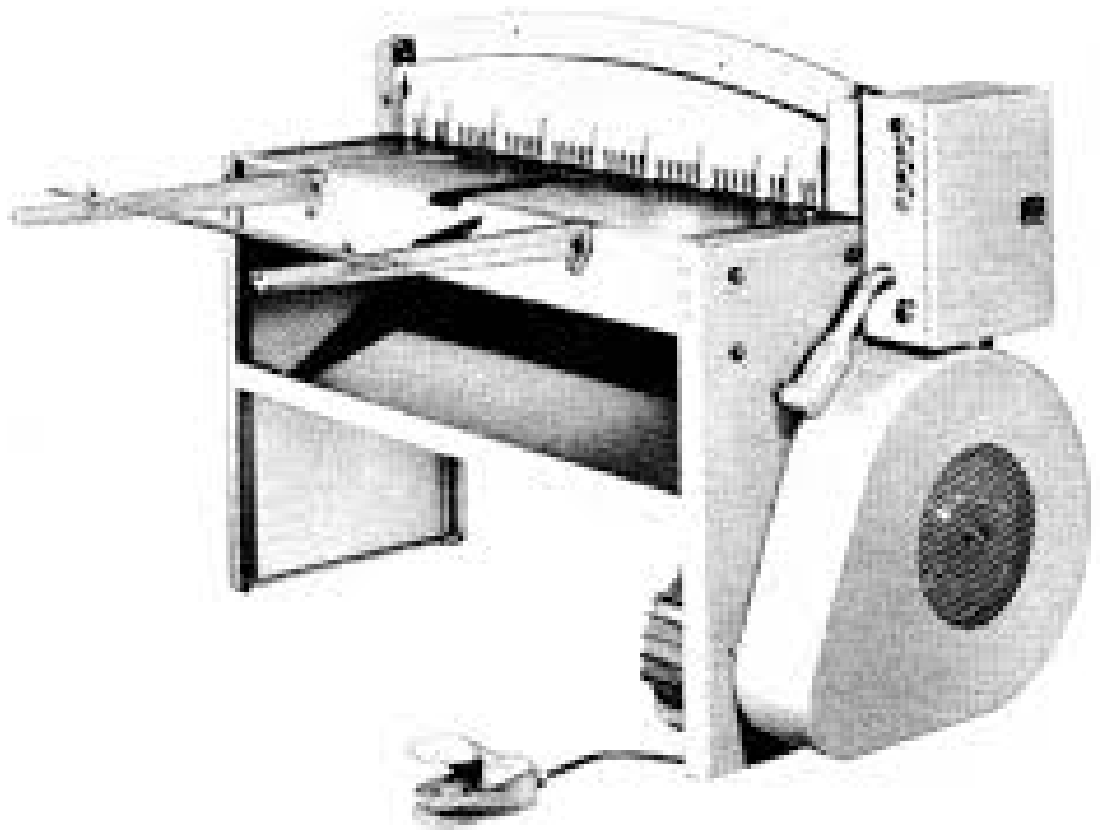

DiAcro[®]
METAL FABRICATION EQUIPMENT

579 SCHOMMER DR - STE C
HUDSON, WI 54016

P: (651) 342-1756

OBSOLETE MACHINE

MANUAL DISCLAIMER

DI-ACRO by supplying this manual is not liable for any indirect, incidental, or consequential damages or injuries sustained or incurred in connection with using the information in any way contained herein.

DI-ACRO accepts no responsibility or liability resulting from attempts to use this information.

DI-ACRO does not vouch for or warrant the accuracy, completeness or usefulness of any information contained herein.

LEVELING AND SECURING

The Di-Aero Power Shear No. 48 should be bolted to the floor to prevent creeping. Shear has three foot pads with bold holes for this purpose, the fourth foot pad is adjustable to compensate for an uneven floor.

After machine has been set in its permanent location, check with a feeler gauge to make certain that the bed is seated on its rails on both side frames.

If Bed is not Seated:

1. Loosen bed clamp bolts A (four) and bed adjusting screw B on side that is not seated.
2. Adjust screw C on foot pad until bed is seated on rail. Tighten lock nut.
3. Check clearance between blades and tighten bed screws A. Note: clearance between blades should be as close as possible without rubbing. Too close a clearance will dull blades and possibly chip them. See page 11 Adjusting Clearance of Blade.

If Bed is Seated:

1. Loosen adjustable screw C on foot pad so that it is not touching the floor.
2. Lower adjustable screw C so that it touches floor, then turn screw in additional one half turn and tighten lock nut. This should eliminate any twist or strain.

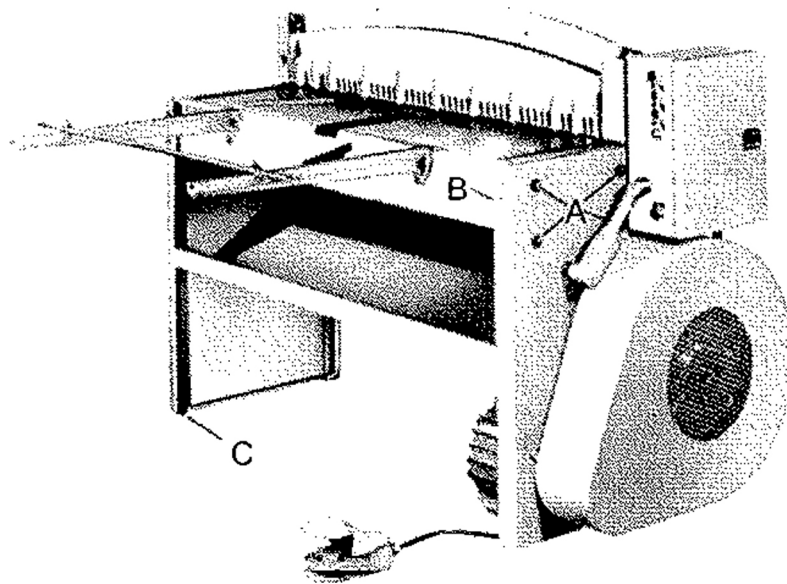

WIRING

Check if motor is wired to proper line voltage. Rotation of the flywheel should be counter-clockwise when facing flywheel end of machine or the top of the flywheel should come toward you when standing in front of the machine. If rotation is wrong, interchange any two of the main line leads.

SEE WIRING DIAGRAM ON PAGE 4

Note: If Shear is equipped with switches for automatic tripping, use wiring diagrams shown on page 5.

CONNECTION DIAGRAM 48 POWER SHEAR

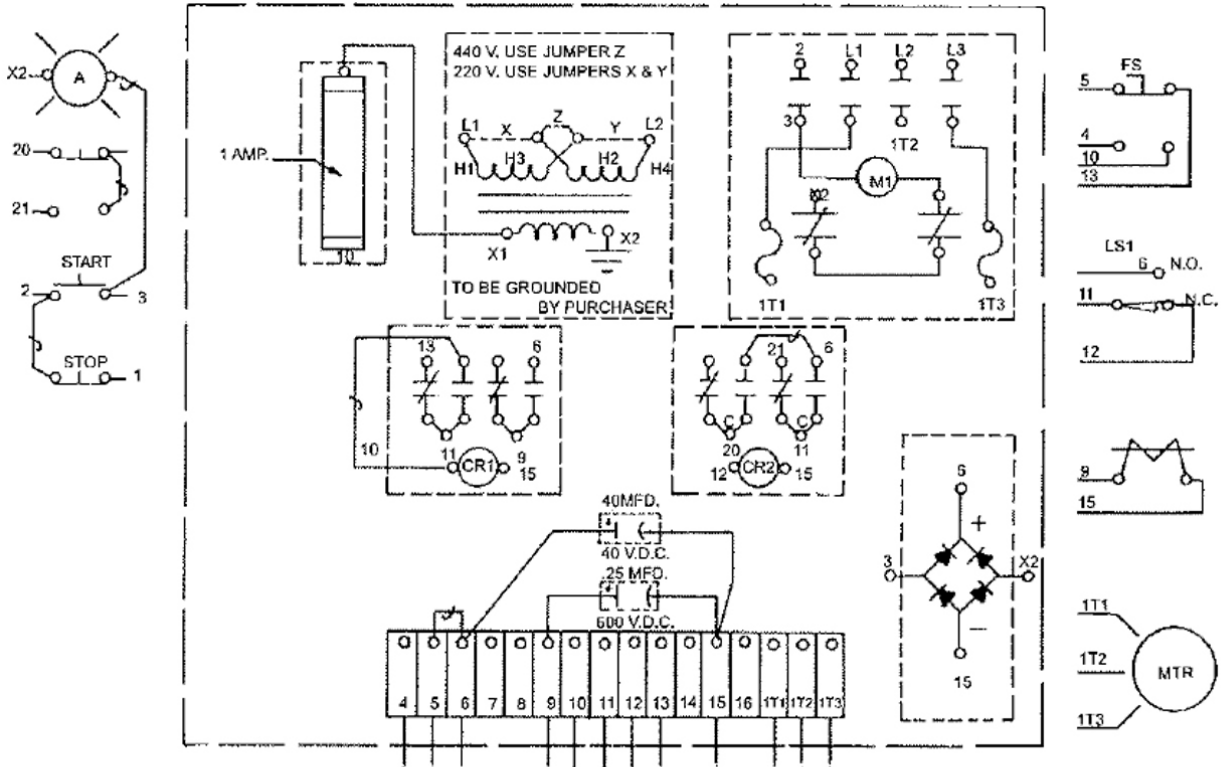

LINE DIAGRAM
48 POWER SHEAR

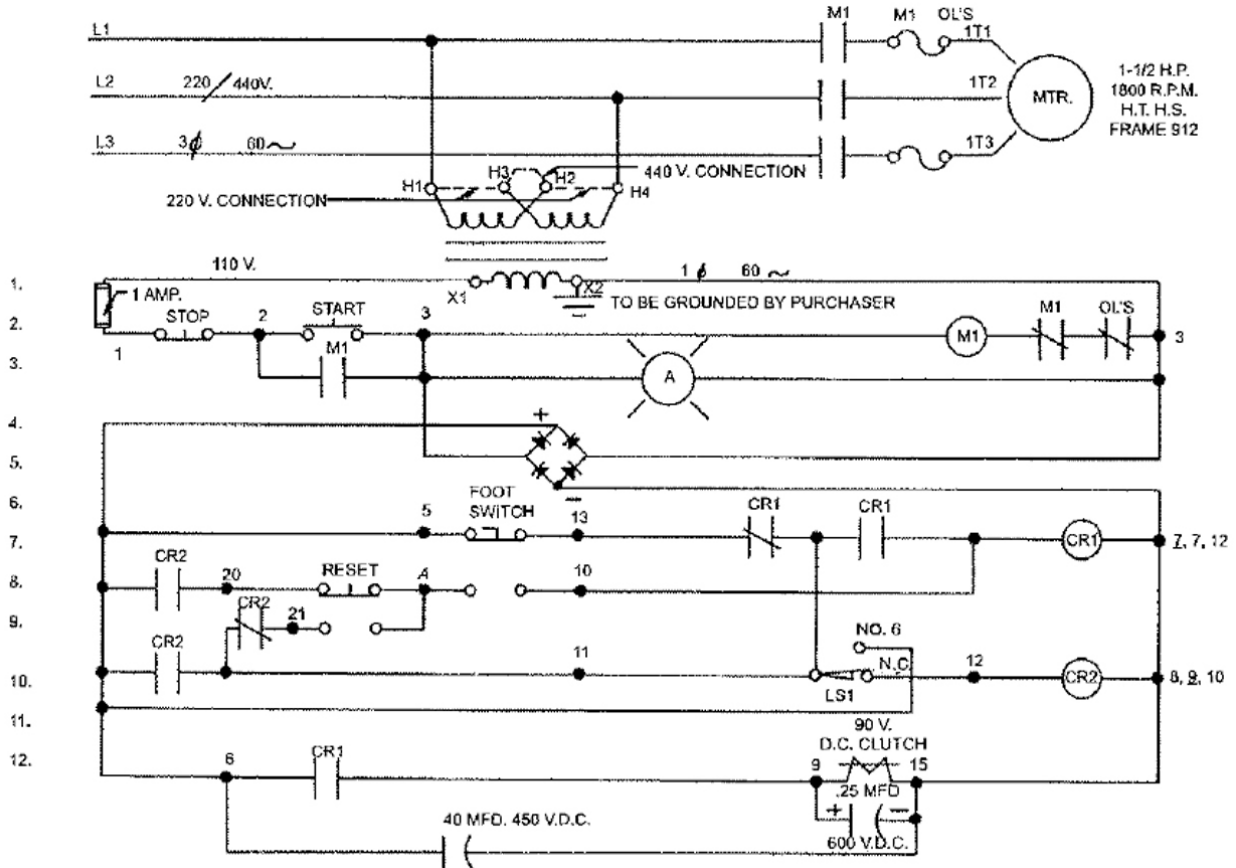

CONTROLS

To start machine press "start" button. When motor is running pilot light will light up. Depress foot pedal. Cutting blade should make a complete shearing cycle and stop. If blade stops at the bottom of the stroke, press "reset" button while simultaneously depressing foot pedal. If blade does not stop at the top of the stroke, the brake is set too loose. Readjust brake (see Brake Adjustment page 12)

NOTE: Machine is not equipped with a jog control. To stop ram at the bottom of the stroke, loosen brake until crankshaft rotates past top center of stroke or rotate shaft by hand (see paragraph 1 page 11)

ADJUSTING GAUGES:

Front gauge is furnished as standard equipment. T-slotted front brackets are bolted to the bed and a gauge bar for supporting and gauging material is provided. The protractor gauge is located on the left side of shearing table.

The standard back gauge dial reads in .001" increments while the closest 1/16" may be read on the scale on the side of the screw housing.

TO PARALLEL GAUGE:

Move in until material stop bar contacts the lower blade. If the bar is not parallel to the blade:

Loosen nut A. Hold opposite end of shaft A to prevent turning

Turn micrometer dial until material stop bar is parallel. Tighten nut A.

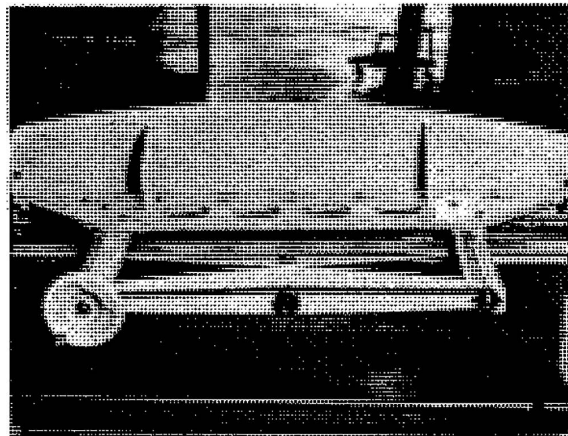

TO ZERO GAUGE:

Loosen screws B on dial and set to zero. Retighten screws. NOTE: to lock back gauge in position, tighten thumb screw C.

TO ELIMINATE BACKLASH:

Tighten set screw located on rear side of bronze lead screw nut.

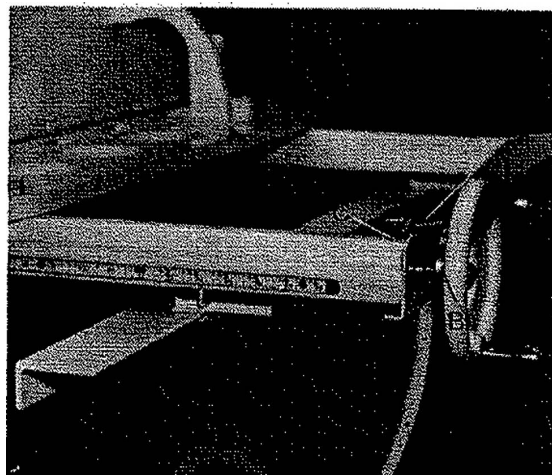

FRONT OPERATED MICROMETER GAUGE

Zero Back Gauge (see page 6 Adjusting Gauges). Instead of zeroing dial, set micrometer counter to desired reading. To lock back gauge in place tighten thumb screw Z.

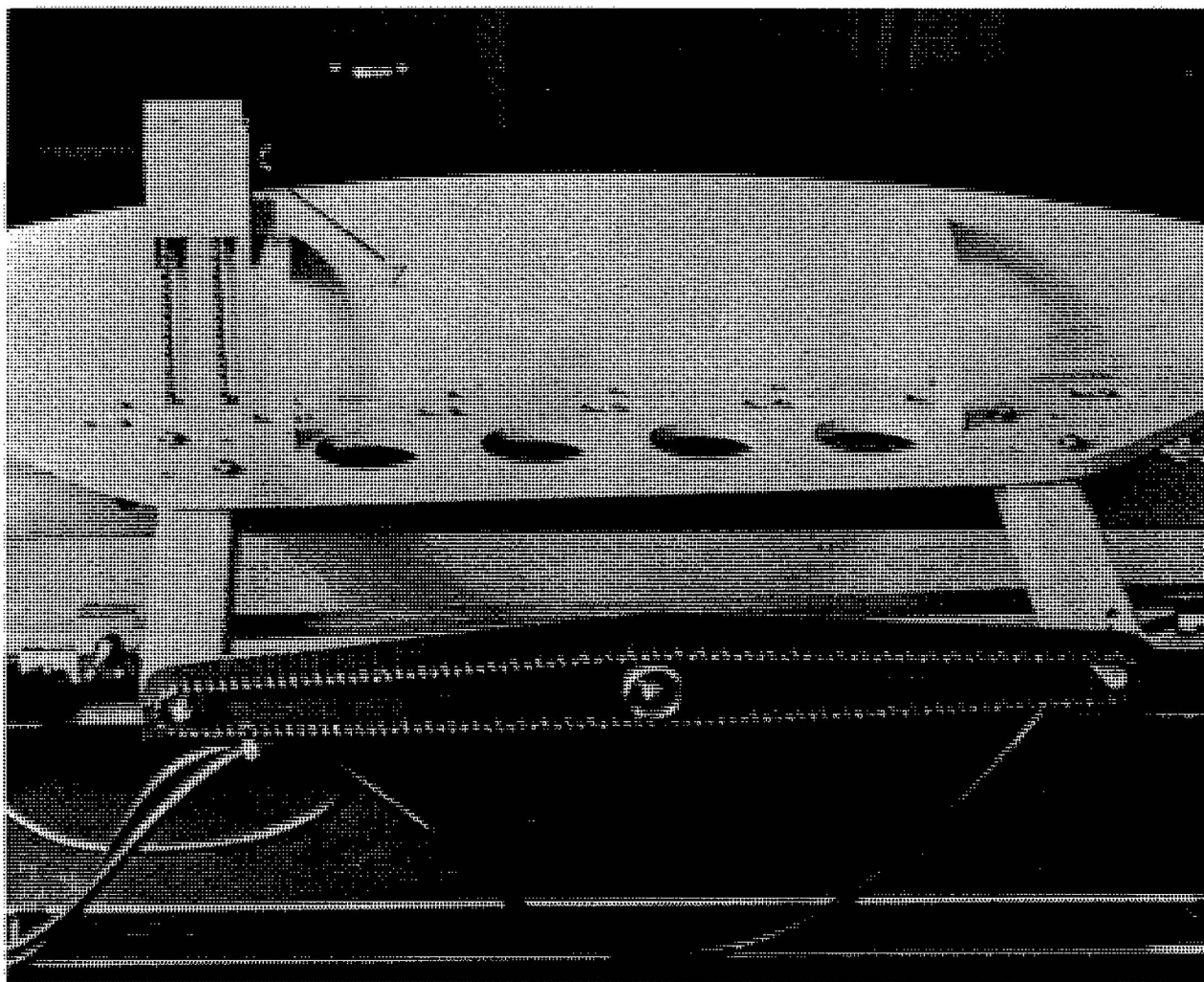

LUBRICATION

Lubricate flywheel bearings, brake release and points indicated in photo below with Mobile Sovare XLT or an equivalent grease. Optional Bijur lubricating system uses Mobil Compound BB or equivalent. Frequency of lubrication will depend on use of machine.

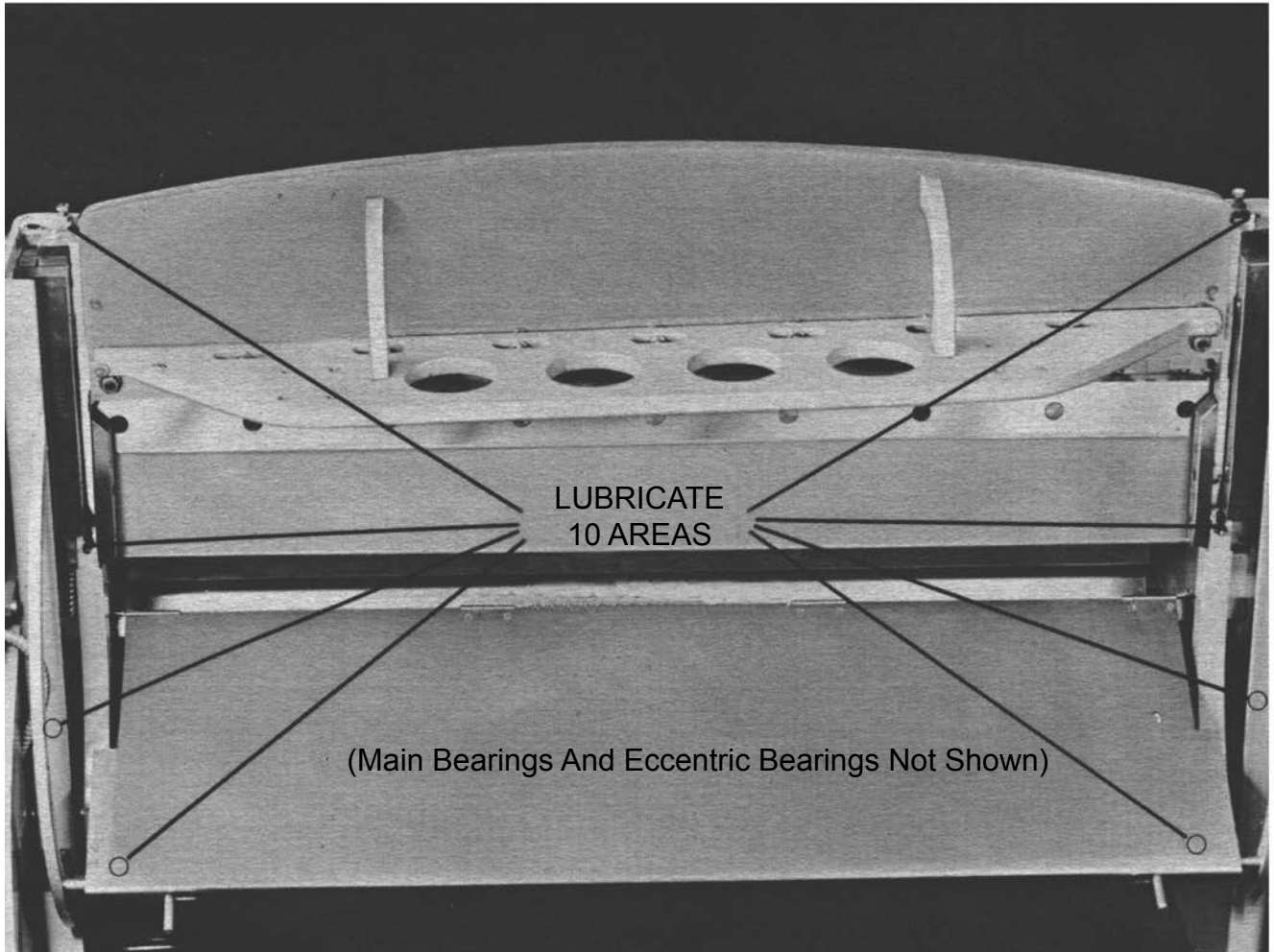

BLADE SHARPENING:

Sharpen the widest sides only as bed can be adjusted in this direction. If other sides are ground it becomes necessary to shim lower blade to raise it to table level.

TO REMOVE LOWER BLADE:

1. Remove flat head bolts X accessible through opening in bottom of bed.

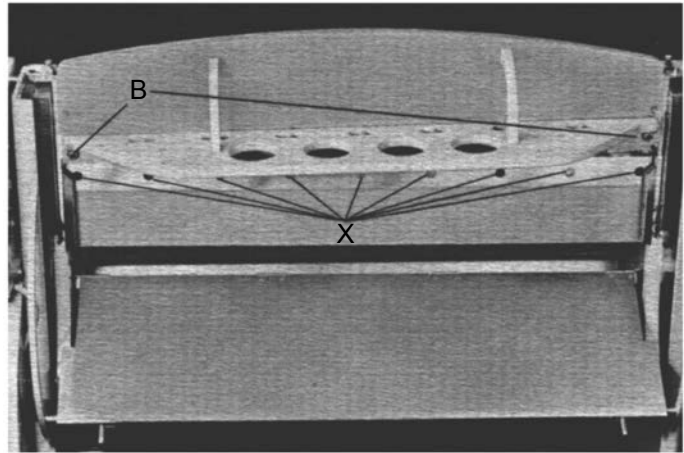

TO REMOVE UPPER BLADE:

1. Back off screws T. Remove holddown pickup stud A through slots in holddown. Remove screws W on ends of holddown and remove from the machine.
2. Remove flat head bolts B fastening blade to ram.

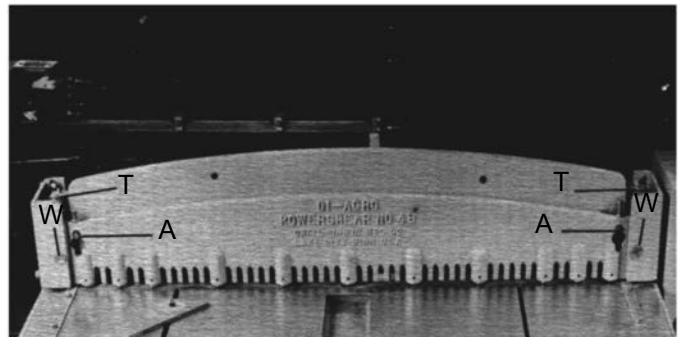

ADJUSTING CLEARANCE OF BLADE:

If bed clamp screws A have been loosened to level machine or blades have been sharpened, it will be necessary to adjust clearance of blades. Blade clearance may be varied but for longer blade life, a few thousandths clearance is better than the blades in actual contact with each other. Best results may generally be obtained with .004" clearance on ends and .002" - .003" in center.

TO ADJUST BLADE CLEARANCE:

1. Insert a bar in crankshaft hole on brake end and turn until ram is at the bottom of its stroke. It may be necessary to loosen brake adjustment knob A (page 12) to rotate crankshaft. Count turns on knob A to aid resetting.
2. Check clearance between blades, adjust to obtain equal clearance on both ends of ram. Opposing screws B & C on both ends will move bed in or out when bed clamp bolts A (both ends) are loose.
3. If clearance is different in center or anywhere along blade, adjust nuts H & J. This will align top blade with lower blade (loosening inner nut and tightening outer nut will pull blade and ram forward or decrease the clearance.)

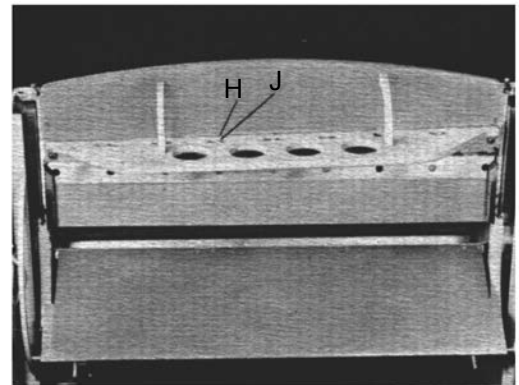
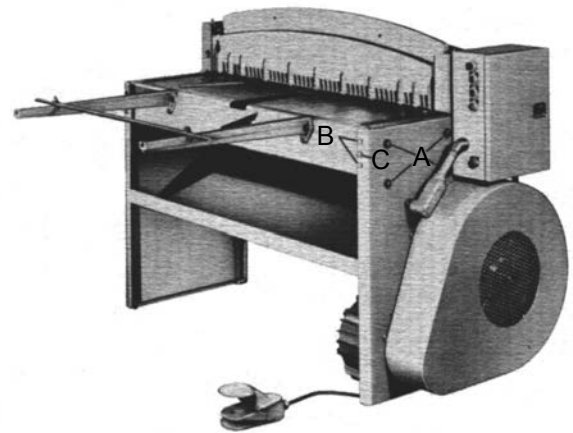

4. When final adjustment is complete, nuts H & J should be licked against blade straightener. Note: Check clearance while this is being done—1/16" of a turn can vary blade straightness approximately .007". Be sure to tighten bed clamp bolts A.

BRAKE ADJUSTMENT:

If machine does not stop at end of the cycle the brake is set too loose.

TO TIGHTEN BRAKE:

1. Turn knob A clockwise slowly while cycling machine until correct operation is acquired. Do not over tighten, as this will put unnecessary strain on the brake release mechanism.

If ram does not return completely to the top of the stroke the holddown will not release the material. This may be caused by the brake being too tight.

TO LOOSEN BRAKE:

1. Turn knob A counterclockwise. Brake is released during shearing operation by rollers B riding up on cam machined on the brake drum.
2. Proper releasing of the brake may be checked by turning the crankshaft by hand with a bar (a hole is provided) until ram is on the downstroke. In this position the brake is released and there should be no drag felt when rotating by hand. If the brake is dragging it may be released by tightening screw C.

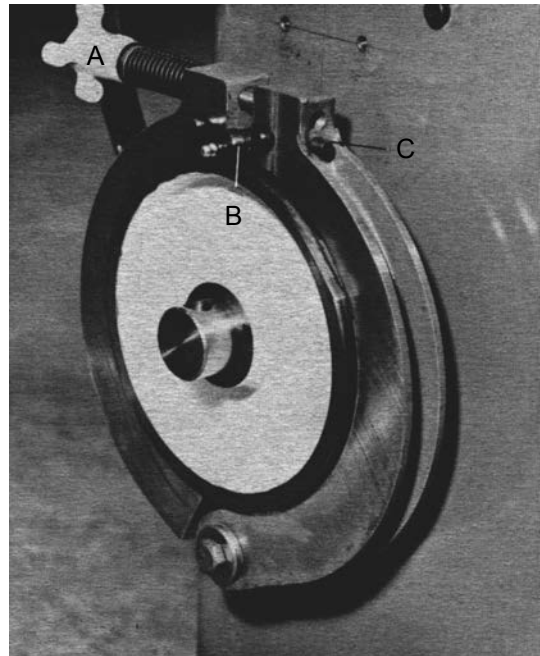

CLUTCH:

The clutch is self-adjusting and should not require any service. For trouble free operation make sure that clutch friction surface and magnet are kept free of oil at all times. When machine is first operated brake may squeal. This will cease as friction surface comes in contact with armature.

EXTENSION SQUARING GAUGE

Shear bed is tapped with two sets of holes for mounting this extension gauge. The inner set is used except where greater capacity in width is required. In normal position (inner holes) material as wide as 48-1/4" can be sheared. The narrower position is preferred, especially when stacking sheared material because there is no interference between sheared material and the ram.

Squaring of the gauge is accomplished with a square along the blade surface. The mounting holes are oversized to allow gauge to be squared. The scale on the bar is adjusted to compensate for sharpening of the blades.

(Height to table approx. 34-1/2")

ADJUSTING HOLD DOWN BAR:

Make sure crankshaft is at top dead center.

1. Loosen screws T.
2. Adjust screws U until holddown opens to desired opening and tighten lock nuts.
3. **Tighten screws T until they bottom on spring, back off two turns for maximum pressure. Tighten lock nuts. Reduce pressure if holddown pads mar material.**
4. **CAUTION:** Do not adjust screw U to raise holddown without readjusting screw T. Failure to adjust both screws will result in damaging holddown pickup studs A.

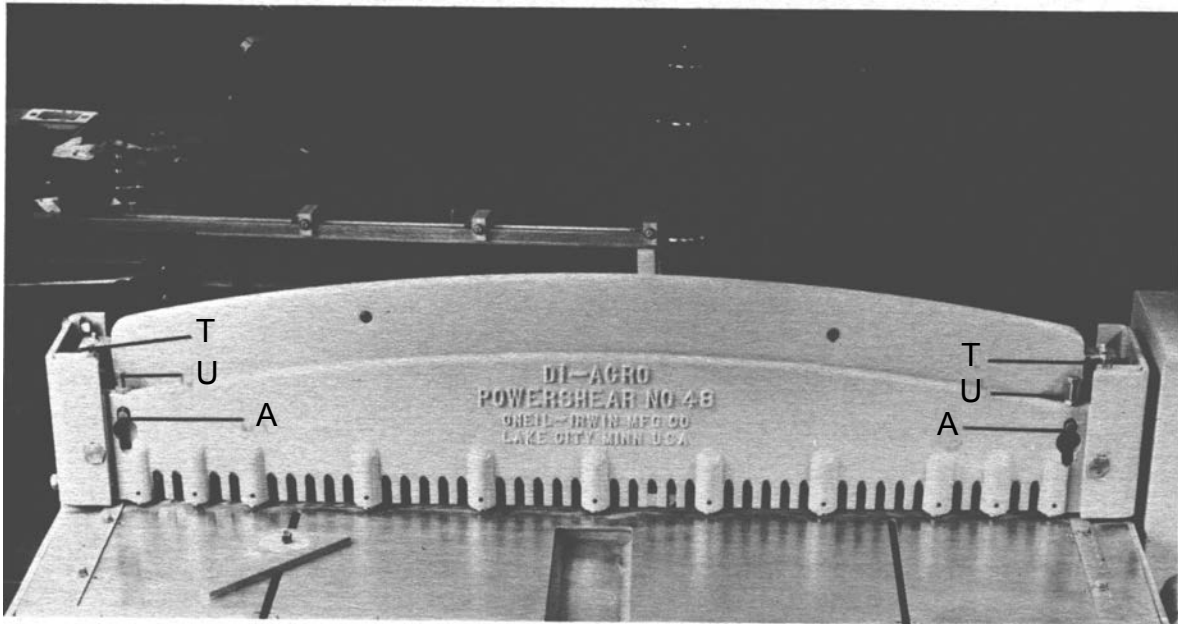

ADJUSTING CLEARANCE ON RAM SLIDES

Standard clearance on ram slides is .002". If less clearance is required or adjustment for wear necessary:

1. Loosen bolt A and remove required amount of shims or grind spacer B.
2. Tighten bolt A.
Recheck clearance with feeler gauge.

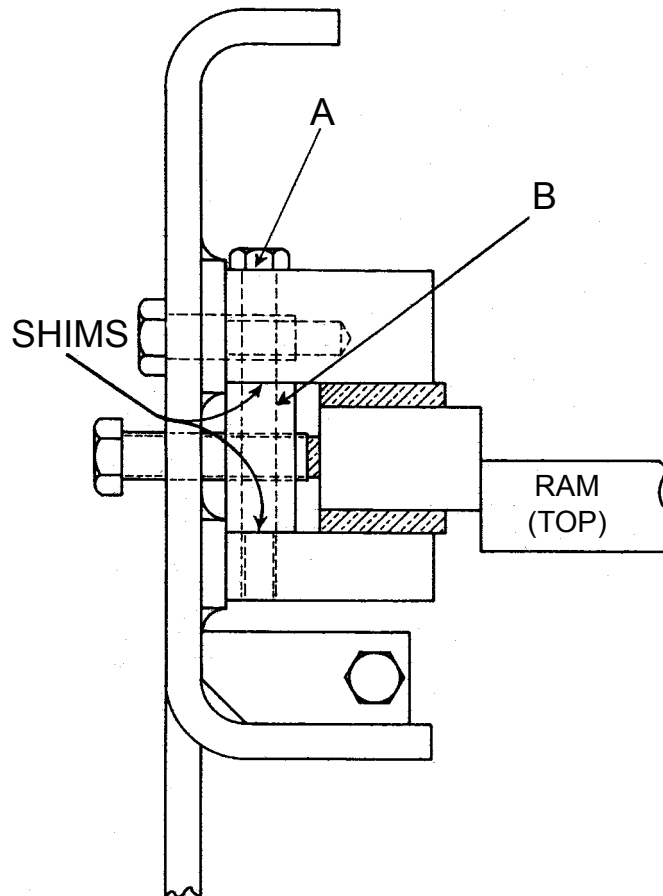

TROUBLE SHOOTING

1. Machine will not operate when foot pedal is depressed.

CAUSE:

Ram is at bottom of the stroke.

REMEDY:

Press reset button while depressing foot pedal.

CAUSE:

Blown fuse in control circuit.

REMEDY:

Replace fuse.

2. Ram will not stop at top of stroke.

CAUSE:

Brake too loose.

REMEDY:

Readjust Brake (see brake adjustment page 12)

CAUSE:

Limit switch not actuating.

REMEDY:

Check to see if cam is operating switch. If not, loosen switch mount and move towards cam.

If cam is actuating switch, replace switch.

3. Holddown will not release material.

CAUSE:

Brake too tight.

REMEDY:

Release brake (see brake adjustment page 12)

CAUSE:

Holddown not set properly.

REMEDY:

Reset holddown (see holddown adjustment page 8)

HANDY TIPS TO GET THE MOST OUT OF YOUR DI-ACRO SHEAR

Di-Acro Shear No. 48 is designed to shear material to extremely close tolerances. For satisfactory result the machine must be level and proper clearance of shear blades maintained. Holddown bar prevents drawing of material to insure straightest possible cut, however, excessive holddown pressure is detrimental. Extreme accuracy and highest degree of straightness is obtained by first shearing material oversize, then cut to finish size by trimming.

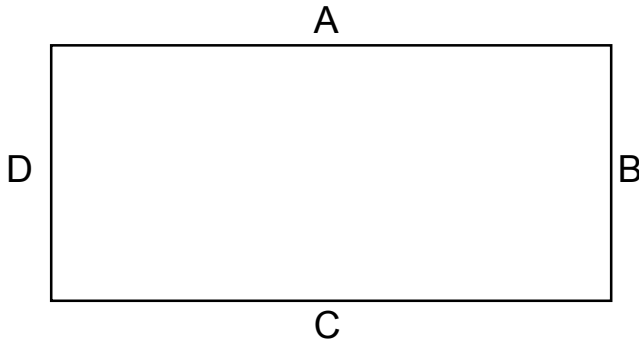

PARALLEL SHEARING

Either front gauge or back is used. The narrower the strip, the greater the difficulty in shearing straight and parallel. The front gauge always gives the most accurate results, especially on narrow widths. It is not necessarily set absolutely parallel with the shear blade to obtain a parallel cut; the difference varies according to the strain in the metal. The most perfect parallel edges are obtained by shearing oversize, then trimming to the exact size.

SHEARING TO A SCRIBED LINE

A scribed line on material can be seen through the openings in the holddown and aligned with cutting edge of shear blades for ordinary accuracy. Most accurate shearing to a line can be done by sighting down between the holddown and ram using the cutting edge of the lower blade for alignment.

SQUARING

Side gauges may not be absolutely square with the shear blade; their position can best be determined by actual shearing. The following method of squaring a sheet will produce the least amount of irregularity. Without turning the sheet upside down between operations, trim long edge A; with edge A against side gauge, trim edge B; with edge A against front gauge, trim long edge C; with edge C against same side gauge used in the second cut, trim edge D.

SHEARING SHORT LENGTHS

When the material to be sheared is narrow or stripped, and the cut is choppy, shearing should be done at the extreme right side of machine

REPETITIONAL SHEARING OF LONG SHEETS

When shearing in lengths greater than the range of the back gauge, or when a predetermined succession of various sizes are to be sheared, a front extension gauge with a series of adjustable stops should be used. The operator moves the sheet forward, then pulls it back to the stop to gauge.

MATERIAL TWIST

The narrower the strip being sheared the greater the amount of twist. Twist can be almost avoided by feeding the sheet from the back and gauging against the front gauge and shearing on the bed in front of the blades.

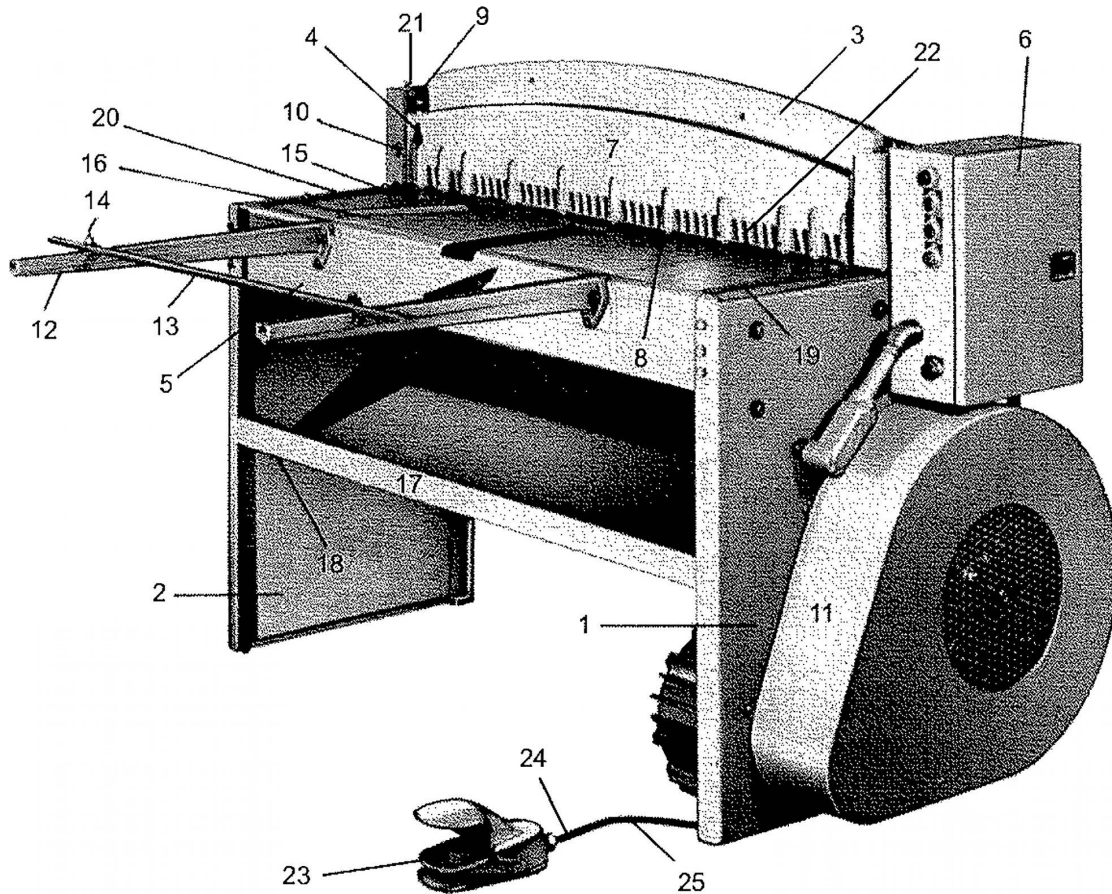

Item No.	Part No.	Description	Item No.	Part No.	Description
1	280-1103001	Side Frame Assy R	17	28080	Front Chute
2	280-1103002	Side Frame Assy L	18	28083	Chute Bracket (2)
3	280-1213015	Ram Assy	19	280-1432102	Squaring Gauge R
4	280-4701023	Holddown Pickup Stud (2)	20	280-1432101	Squaring Gauge L
5	280-1104030	Bed Assy	21	5102112	Holddown Spring
6	280-3307062	Control Enclosure	22	280-1106113	Plastic Guard
7	280-1213066	Holddown Bar	23	3303002	Foot Switch Assembly
8	280-1213067	Holddown Pads (11)	24	3315209	Cord Grip Assembly
9	280-1213068	Holddown Spring Plug (2)	25	3316912	Black Cord
10	280-1213069	Holddown Guide		3322006	Brush Holder Assembly
11	280-1106071	Drive Belt Guard		3370001	Brushes
12	280-1434072	Front Gauge Extension (2)		3317009	Light Bulb
13	280-1434073	Front Gauge		6999004	Rubber Stem
14	4701135	T Bolt (3)		4701103	Blade Screw Lower
15	28075	Protractor Clamp		4701102	Blade Screw Upper
16	23628	Protractor Body			

Item

No.	Part No.	Description
1	280-1108005	Rear Guide (2)
2	280-1108006	Front Guide (2)
3	280-1108007	Ram Guide Spacer (2)
4	280-3107008	Thrust Bearing
5	28009	Take Up Screw
6	280-5701011	Ram Guide Shims
7	280-3120021	Ram Slide A (2)
8	280-3120022	Ram Slide B (2)
	2803322	Electric Clutch
	3322008	Mg for Clutch
	3104137	Roller Brg
	4705019	Lok Ring
	31X0102C	Hex Jam Nut
	5102114	Spring

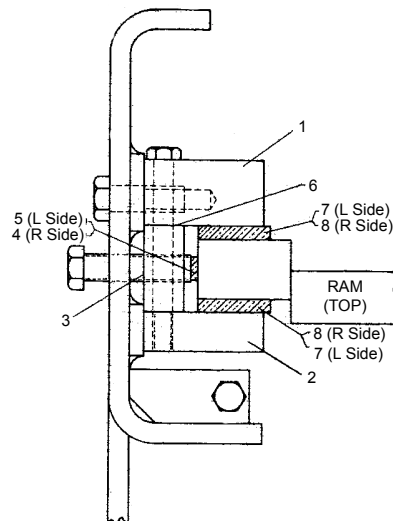

Item

No.	Part No.	Description
1	280-1106026	Brake Guard (not shown)
2	280-1203027	Brake Release Pin (C)
3	280-1203028	Brake Release Pin (A) Bijur
4	280-1207029	Brake Release Roller
5	280-1203033	Brake Release Pin (A)
6	280-1203034	Brake Release Pin (B)
7	280-1207045	Brake Drum
8	280-1207046	Brake Shoe R
9	280-1207047	Brake Shoe L
10	280-4701048	Brake Adj Screw
11	280-1207049	Brake Adj Knob
12	280-1203050	Torque Pin
13	4901114	Washer
14	280-1207052	Brake Link (4)
15	280-1207055	Brake Lining (2)
	4703102	Rivet
	280-1207712	Brake Assembly
	280-1207701	Brake Shoe Assy R
	280-1207702	Brake Shoe Assy L

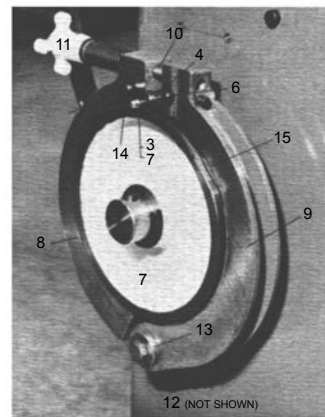

Item

No.	Part No.	Description
1	280-1432090	Extension Squaring Arm Bar L
2	280-1432091	Sheet Support
3	280-1601092	Rule
4	280-1432093	Leg Assy
5	280-1432094	Gauge Stop Body R (2)
6	280-1432095	Gauge Stop L
7	280-1432096	Extension Squaring Arm Bar R
8	280-1432097	Gauge Staop Body R (2) L
9	280-1432098	Gauge Stop R

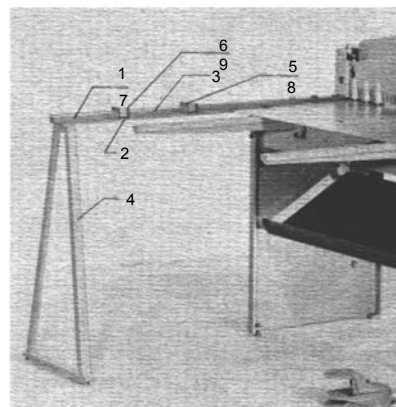

Item

No.	Part No.	Description
1	280-1205035	V Belt Sheave
2	280-1204036	Flywheel

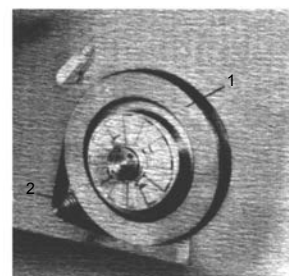

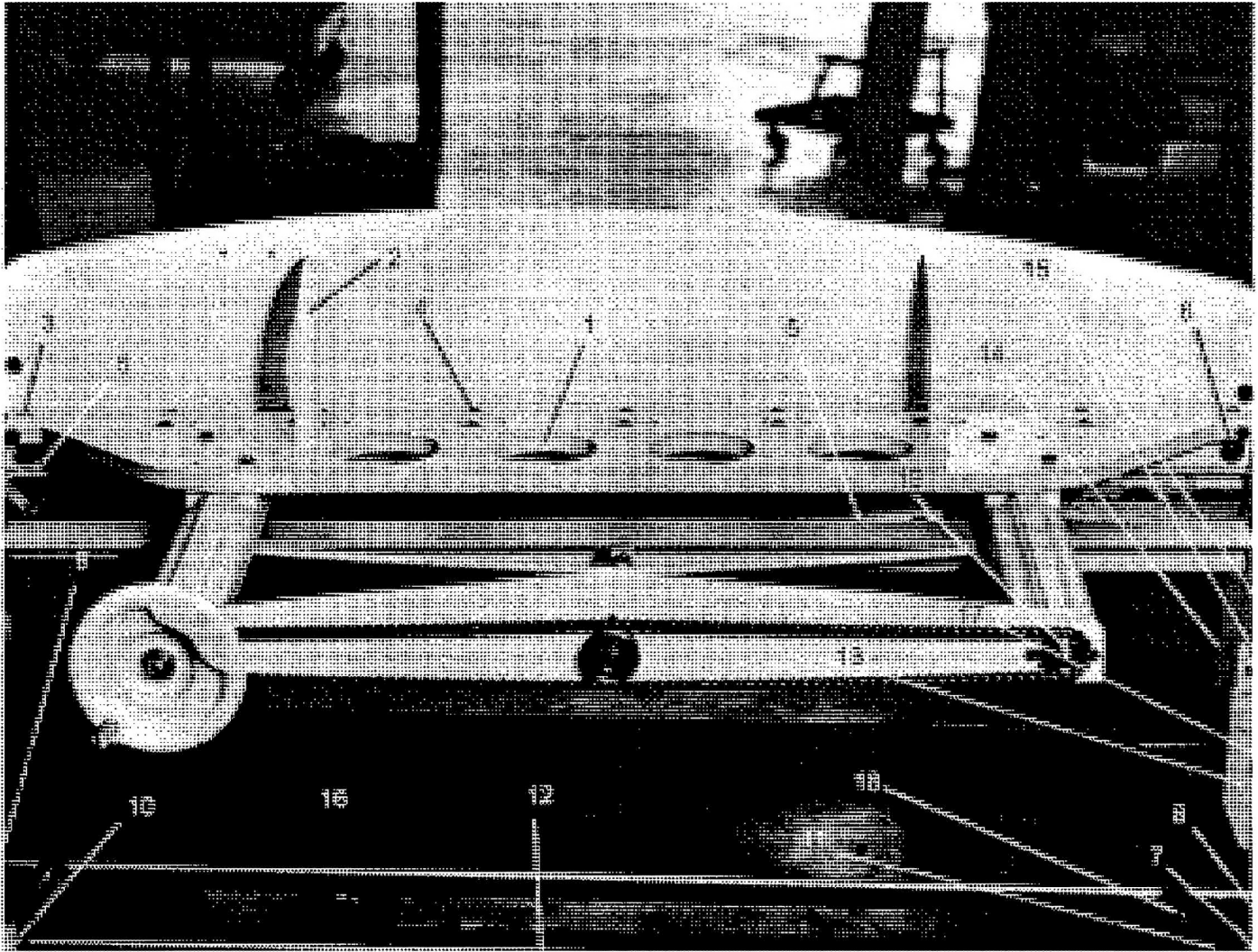

Item No.	Part No.	Description	Item No.	Part No.	Description
1	280-1213016	Blade Straightener	11	280-1202042	Eccentric L
2	280-1213017	Ram Gusset (2)	12	280-1201043	Crankshaft
3	280-1108018	Spacer (2)	13	280-1212044	Pitman (2)
4	280-4701019	Stud Bolts (7)	14	280-1203053	Pitman Pin (2)
5	280-0000611	Blades	15	280-4706054	Pin Retainer (2)
6	280-0000610	Washer	16	280-1109081	Rear Chute
	280-1209040	HCHC (2)	17	280-1109082	Support Angle (not shown)
	280-1209024	Alloy (2)	18	280-1109085	Adjustment Pin (2)
7	280-1103038	Main Bearing Housing	19	281-5301013	Lead Screw Sprocket A
8	280-3106039	Main Bearing (2)			
9	28040	Switch Cam (not shown)			
10	280-1202042	Eccentric R			

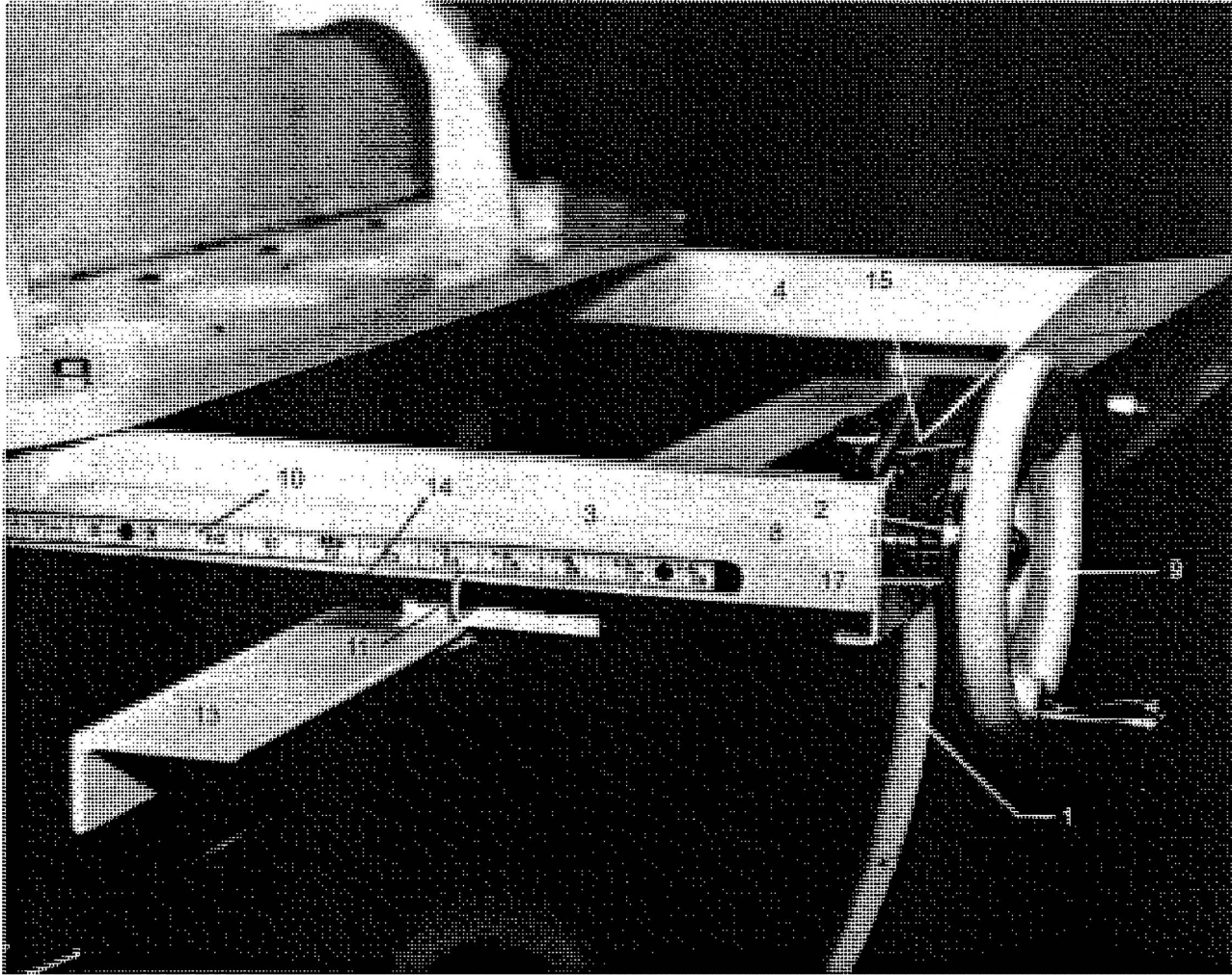

Item No.	Part No.	Description	Item No.	Part No.	Description
1	280-1109084	Angle Stop (2)	11	281-1431008	Rule Indicator
2	280-1603099	Calibration Ring	12	281-1431009	Truss Bar
3	281-1431000	Lead Screw Housing R	13	281-1431010	Gauge Bar
4	281-1431001	Lead Screw Housing L	14	281-1431011	Housing Cap (4)
5	281-1431002	Lead Screw R (not shown)	15	281-1431015	Dial Pointer
6	281-1431003	Lead Screw L (not shown)	16	281-5301013	Lead Screw Sprocket A
7	281-4704004	Lead Screw Nut (not shown)	17	281-5301014	Lead Screw Sprocket B
8	281-1431005	Spacer Sleeve		5102113	Spring
9	281-1431006	Gauge Wheel		25X0102X1104	Shoulder Bolt
10	281-1601007	Rule		280-5901001	Counter

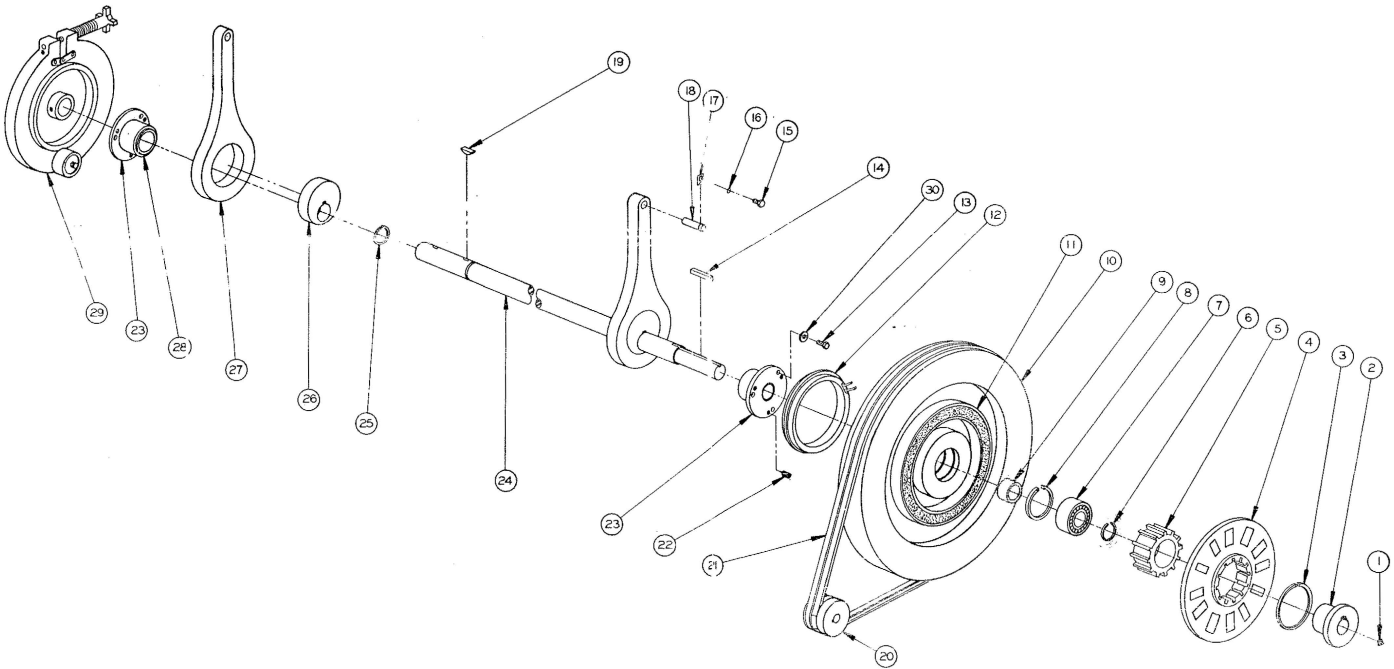

Item No.	Part No.	Description	Qty Used
1	6901004	Grease Fitting	1
2	3322003	Bushing 1-1/2	1
3	3322005	Retaining Ring	1
4	280-3322078	Armature	1
5	3322004	Splined Hub	1
6	4705110	Retaining Ring 1-9/16	1
7	3102002	Ball Bearing	2
8	4705108	Retaining Ring 3-5/32	2
9	280-1108037	Bearing Spacer	1
10	280-1204036	Flywheel	1
11	3322008	Magnet	1
12	3322001	Collector Ring and MTG	1
13	21Z0308C1000	HEX HD Cap SCR	6
14	5501121	Key 3/8 SQ x 2-3/4	1
15	21A0104C0304	HEX HD Cap SCR	2
16	4902005	LK Wash 1/4 M	2
17	280-4706054	Pin Retainer	2
18	280-1203053	Pitman Pin	2
19	5501102	WDF Key 1211	3
20	280-1205035	V Belt Sheave	1
21	4401004	V Belt 7/A75 Set -2	1
22	23A0516C0308	Socket Set SCR	6
23	280-1103038	Main Bearing Housing	2
24	280-1201043	Crankshaft	1
25	4705106	Retaining Ring 1-3/4	2
26	280-1202042	Eccentric	2
27	280-121201	Pitman SUR ASSY	2
28	280-3106039	Main Bearing	2
29	280-1207712	Brake Assembly	1
30	4902008	Lockwasher 3/8	6