

DI-ACRO #36 FINGER BRAKE INSTRUCTION MANUAL



Di-Acro[®]
METAL FABRICATION EQUIPMENT

579 Schommer Dr - Ste C

Hudson, WI 54016

Phone: 651.342.1756

Email: info@diacro.com

TABLE OF CONTENTS

SAFETY INFORMATION	PG. 3
SPECIFICATIONS	PG. 3
ANGLE ADJUSTMENT	PG. 4
MICROMETER BACKGAUGE	PG. 5
#36 FINGER BRAKE BREAKDOWN AND PARTS LIST	PG. 6-8
MICROMETER BACK GAUGE	PG. 8
OPTIONAL STAND	PG. 9
WARRANTY	PG. 10

SAFETY INFORMATION



Before brake is set up for operation, mount on work bench or stand. Ensure the base is flush with the front edge of the stand or work bench, and bolt in place and secure stand to the floor.

***IF BRAKE IS MOUNTED ON ITS OWN STAND, SECURE STAND TO FLOOR.**

SPECIFICATIONS	No. 36	
	in.	mm
Max. Capacity, Mild Steel	16 ga.	1.5
Max. Forming Width	34	914.4
Clearance thru Top Opening	1	25.4
Max. Depth of Box or Pan	3	76.2
Min. Reverse Bend	1/4	6.4
Max. Angle Bend (one operation)	135°	
Max. Back Gauge Adjustment	24	609.6
Shipping Weight	470#	123 kg
Stand, Shipping Weight	140#	63 kg

ANGLE ADJUSTMENT

To adjust Brake for bending clearance, raise folding blade 90 degrees, insert material between edges of folding blade and leading edge of fingers (for heavy material, clearance should be twice the thickness, less for lighter gauge or if sharper bend is desired). Adjust finger mount weldment by turning arm adjustment bolts (item 48). To adjust clamping pressure, insert material under fingers and turn arm adjustment bolts until material is held securely when fingers are lowered. To adjust degree of bend, pins (item 44) located on both ends of folding blade for desired degree of bend.

REVERSE BENDS

Remove the five Hex head cap screws 3/8-16x1 (item 67) the support bar (item 64) and adjust Brake as shown.

NOTE: Based on 16 gauge material. (with support bar in place)

MINIMUM LENGTH OF BEND WHEN FORMING A REVERSE BEND = 1/4

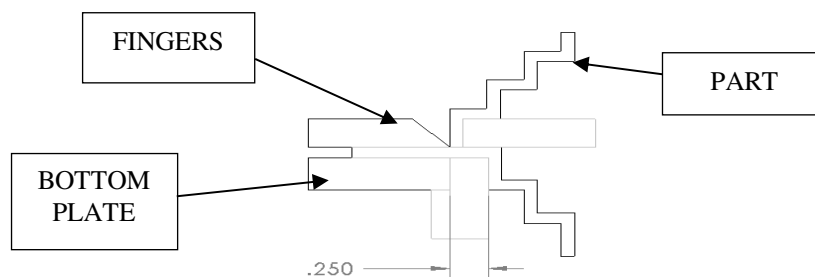

NOTE: Di-Acro Brakes are rated for 1" minimum flange when bending full capacity. Caution should be used if necessary to bend heavier gauge material in short widths.

MICROMETER BACK GAUGE ASSEMBLY - #8348144-170

Typically the back gauge is assembled when the finger brake is shipped from the factory. Occasionally it is removed for ease of palletizing. To install and/or zero the gauge follow the instructions below.

1. Install Quik-Set rod (item 82) in holes located in rear of the base casting.
2. Set Quik-Set nut assembly (items 79, 80 and 83) on zero and screw rods in until gage (item 78) lines up with folding blade. Quik set rods can be locked in place by tightening screws located behind folding blade.
3. To position micrometer back gauge rapidly, turn dial nut assemblies to zero. Depress the nut assembly and slide complete back gauge to desired position. For fine adjustment turn rotate dial nut assemblies in regular manner.

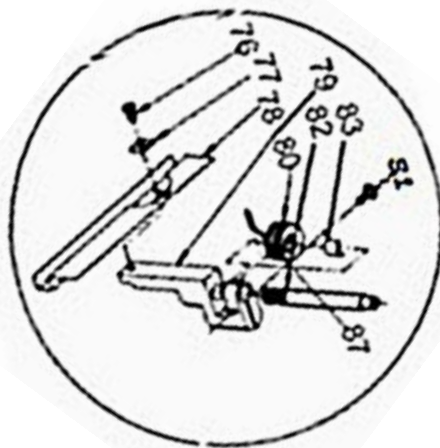

#36 FINGER BRAKE 8348820-080

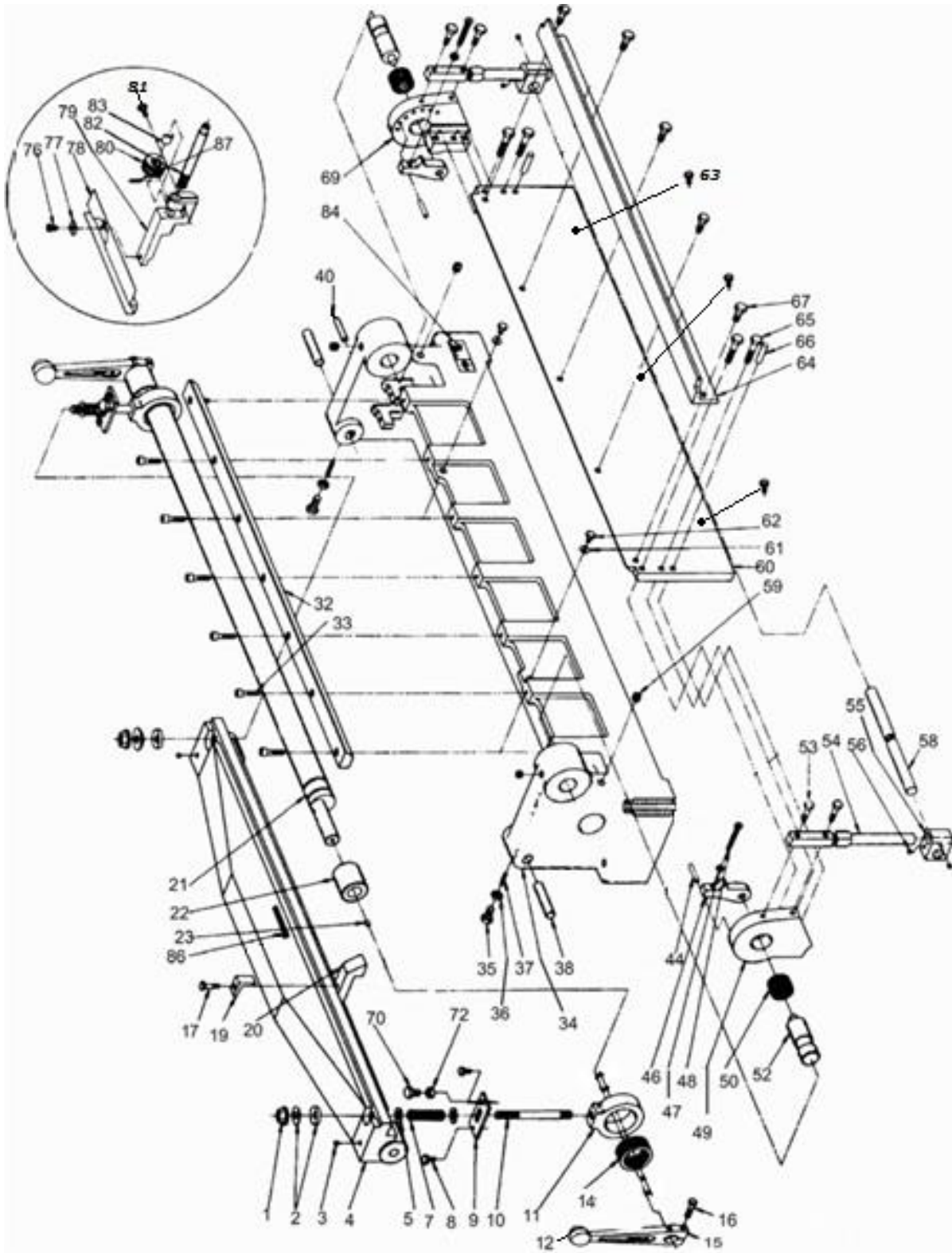

PARTS LIST

ITEM	PART NUMBER	DESCRIPTION	QTY
1	30X0102C	NUT-FULL 1/2-13	2
2	8490500-100	WASHER SET	2
3	23A0104C0308	SCREW-SSS 1/4-20X3/8	2
4	8348111-000	FINGER MOUNT	1
5	8348310-700	THRUST BRG	4
7	8348510-200	SPRING	2
8	21A0104C0102	SCREW-HHCS 1/4-20X1/2	4
9	8348140-700	SPRING BRACKET	2
10	8348121-100	STUD	2
11	8348121-200	CONNECTING ARM	2
12	8120810-700	PLASTIC KNOB	1
14	8310300-900	NEEDLE BEARING	2
15	346-1208030	CLAMP HANDLE BLOCK	1
15A	8500111-300	CLAMP HANDLE ROD	1
16	21A0516C1104	SCREW-HHCS 5/16-18X1-1/4	1
17	21A0516C1308	SCREW-HHCS 5/16-18X1-3/8	16
19	8347110-203	FINGER CLAMP	16
20	8000122-203	FINGER STD 3/4	2
20	8100122-203	FINGER STD 1	2
20	8000122-204	FINGER STD 1-1/4	2
20	8200122-203	FINGER STD 3	2
20	8347122-204	FINGER STD 6	4
21	8700122-000	BRAKE SHAFT	1
22	8346110-302	BEARING ASSEMBLY (SEE BELOW)	
	346-1103024	BUSHING HOUSING	2
	8346110-302-1	BRONZE BUSHING	2
23	8690100-200	DRIVE FITTING	2
32	8348110-400	BOTTOM PLATE	1
33	20A0516X1000	SCREW-SHCS 5/16-18X1	7
34	8348110-100	BASE	1
35	21A0308C1304	SCREW-HHCS 3/8-16X1-3/4	2
36	31X0308C	NUT-JAM 3/8-16	2
37	8060510-205	SPRING	2
38	19A0508X3102	PIN-DOWEL 5/8X3-1/2	2
40	18A0308X2102	PIN-SPRING 3/8X2-1/2	1

PARTS LIST - CONTINUED

ITEM	PART NUMBER	DESCRIPTION	QTY
44	19A0104X1000	PIN-DOWEL 1/4X1	2
46	8500122-000	FOLDING BAR STOP	2
47	31X0516C	NUT-JAM 5/16-18	2
48	8251470-101	ARM ADJUSTMENT BOLT	2
49	8400122-000	LEFT ARM	1
50	8310300-600	NEEDLE BEARING	2
52	8346120-300	TRUNNION	2
53	21A0308C1102	SCREW-HHCS 3/8-16X1-1/2	4
54	8346120-801	HANDLE ARM	2
55	8348131-000	HANDLE BLOCK	2
56	23A0104C0308	SCREW-SSS 1/4-20X3/8	2
58	8348131-200	HANDLE CROSS BAR	1
59	23A0102C0102	SCREW-SSS 1/2-13X1/2	4
60	8348122-001	FOLDING BAR FRONT	1
60A	8348122-002	FOLDING BAR REAR	1
61	61X0104	WASHER-FLAT 1/4	2
62	21A0104C0102	SCREW-HHCS 1/4-20X1/2	2
63	20C0104C0304	SCREW-FHSCS 1/4-20X3/4	3
64	8600122-600	FOLDING BAR SUPPORT	1
65	21A0308C1104	SCREW-HHCS 3/8-16X1-1/4	4
66	19A0308X1102	PIN 3/8X1-1/2	2
67	21A0308C1000	SCREW-HHC 3/8-16X1	5
69	8346122-000	RIGHT ARM	1
70	21A0308F0304	SCREW-HHCS 3/8-24X3/4	2
72	30X0308F	NUT-FULL 3/8-24	2
76	21A0104C0102	SCREW-HHCS 1/4 -20X1/2	2
77	8346144-106	BLOCK	2
78	8348144-100	GAUGE	1
79	8346144-103	QUICK SET BRACKET	2
80	8210143-104	QUICK SET DIAL NUT	2
81	22B0104C0708	SCREW-FLHMS 1/4-20X7/8	2
82	8046144-103	QUIK SET ROD	2
82A	22D0516C0102	SCREW-THMS 5/16-18X1/2	2
83	8000143-104	QUIK SET DIAL SHOE	2
86	8150650-110	LABEL - NAMEPLATE	1
87	8210510-204	SPRING	2
	8030650-301	LABEL – PINCH POINT	1
	030-6503001	LABEL – CAUTION	1

OPTIONAL STAND

Part Number: 838110-900

Stand Dimensions: 48" WIDE, 15" DEEP, 33-1/4" HIGH

CALL DI-ACRO FOR PRICE AND AVAILABILITY



Fasteners needed to attach Finger Brake to stand are the following:

(Fasteners to attach stand to floor are not included.)

PART NUMBER	DESCRIPTION	QTY
21A0102C4102	SCREW-HHCS 1/2-13X4-1/2	4
61X0102	WASHER-FLAT 1/2	4
30X0102C	NUT-FULL 1/2-13	4

Warranty & Limitation of Liability

Defective parts, of a product manufactured by DI-ACRO, will be replaced or repaired at no charge for twelve (12) months following delivery to the original purchaser. Labor is included for the first 90 days. This warranty becomes void when products have not been used according to instructions furnished by DI-ACRO, nor does it cover any altered parts or unauthorized repairs. We cannot be responsible for the cost of repairs made or attempted outside of our factory. All other warranty claims are made FOB our plant, providing such items(s) is returned freight prepaid to our plant for examination.

This warranty does not apply to parts, components or systems not manufactured by DI-ACRO. These products are covered instead by the existing warranties, if any, of their manufacturers. Normal service items with a reasonable life expectancy of less than one year are warranted only to the extent of the reasonable life under normal use and service.

Authorization must be obtained from DI-ACRO before returning parts or equipment to the factory. DI-ACRO will satisfy this warranty by replacing the product or refunding the purchase price upon receipt, inspection and defect identification.

DI-ACRO's liability under this warranty shall not exceed the amount paid for the product.

THIS IS DI-ACRO'S SOLE WARRANTY IN LIEU OF ALL OTHER WARRANTIES, EXPRESS OR IMPLIED, WHICH ARE HEREBY EXCLUDED, INCLUDING IN PARTICULAR ALL WARRANTIES OF MERCHANTABILITY, FITNESS OR ANY LOSS, DAMAGE OR EXPENSES DIRECTLY OR INDIRECTLY RELATED TO THE USE OF ITS PRODUCT OR FROM ANY OTHER CAUSE OR FOR CONSEQUENTIAL DAMAGES INCLUDING, WITHOUT LIMITATION, LOSS OF TIME AND LOSS OF PRODUCTION.

IT IS EXPRESSLY UNDERSTOOD THAT DI-ACRO IS NOT RESPONSIBLE FOR DAMAGE OR INJURY CAUSED TO OTHER PRODUCTS, MACHINERY, PROPERTY OR PERSONS BY REASON OF THE USE OF ITS PRODUCTS.



579 Schommer Dr - Ste C

Hudson, WI 54016

Phone: 651.342.1756

Email: info@diacro.com