

®
Di-Acro

24 Standard & Vari-0- Speed Di-Acro Power Shears



Di-Acro®

METAL FABRICATION EQUIPMENT

579 SCHOMMER DR - STE C

HUDSON, WI 54016

(651) 342-1756 (P)

OBSOLETE MACHINE
MANUAL DISCLAIMER

DI-ACRO by supplying this manual is not liable for any indirect, incidental, or consequential damages or injuries sustained or incurred in connection with using the information in any way contained herein.

DI-ACRO accepts no responsibility or liability resulting from attempts to use this information.

DI-ACRO does not vouch for or warrant the accuracy, completeness or usefulness of any information contained herein.

**POWER SHEARS
OPERATOR'S MANUAL
MODELS – 24 STANDARD &
24 VARI-O-SPEED**

This instruction manual serves two purposes: 1. It outlines essential information for installation, operation and maintenance of Di-Acro 24 Power Shears: 2. It gives a complete, parts breakdown identified by number, should replacements be required.

It is recommended that the operator be familiar with the Shear's construction and operating details. It is also recommended that the foreman or supervisor familiarize himself with the operating details of the machine to insure its continued efficient service.

The 24 Power Shear is designed for shearing small parts on a production basis. The capacity is 16 ga. low carbon steel (50,000 PSI shear strength) x 25 inches in width. The maximum clearance under the holddown and lower end of the blade allows for the feeding of sheets up to 1/8" thick. NOTE: Maximum shear capacity is reduced to 25,000 PSI shear strength at this thickness. (See table of equivalents) CAUTION: Do Not Shear Music Wire or Other Hardened Wire As Blades Will Be Damaged.

TABLE OF CONTENTS

Technical Data	3
Installation	4
Operating Procedures	5
Machine Adjustments	6, 7
Parts Breakdown	9-16

FOR ORDERING PARTS, SEE PARTS LIST SECTION

CONSTRUCTION FEATURES

All electricals (disconnect switch and 115 volt to controls for safety)
 Material Hold-Down Bar
 Side Squaring Gauge
 Reversible Protractor Gauge
 Set of Four-Edged Alloy Tool Steel Blades
 Micrometer Back Gauge

ACCESSORIES

Hi-Carbon/Hi-Chrome Blades

SPECIFICATIONS

	STANDARD NO. 24	VARI-O-SPEED NO. 24
Capacity: Mild Steel	16 gauge	16 gauge
Blade Length	24-1/8"	24-1/8"
Blade Size	15/32" x 1-7/32"	15/32" x 1-7/32"
Blade Rake	3/8" - to the foot	3/8" - to the foot
Cutting Speed-Continuous	90	30-150
Cutting Speed-Single Stroke	2/3 above	2/3 of above
Motor	3/4 hp gear type	3/4 hp
Specify Wiring-Other	230/460 volt, A.C.	230/460 volt, A.C.
Voltage Requirements and	3 phase	3 phase 1200
RPM - On Special Quotation	U.S. Syncrogear	U.S. Varidrive
Back Gauge Range	12-3/4"	12-3/4"
Font Gauge Range		
Overall Width	40"	40"
Overall Depth	18-1/2"	18-1/2"
Overall Depth With Rear Gauge	27"	27"
Overall Depth With Front Gauge		
Shipping Weight, Lbs.	660	710

Leveling or fastening is not required when installing the shear. However, it is important that the three mounting pads on the bottom of machine are always in contact with the floor or twist in machine may occur.

Remove all rust preventative with cleaning solvent.

Connect 3 phase power to disconnect switch line terminals, making sure the wiring is correct for the motor and transformer.

Jog "start" switch to check for proper rotation. See arrow decal on chain guard. If rotation is wrong, interchange two of the main line leads.

Check lubrication before starting production.

LUBRICATION

Fill oil cups (Fig. 1) with Mobil Vactra No. 4 or equivalent way oil.

Check gear case on gear reducer to see if it is filled to proper level. Use a turbine oil with a viscosity as indicated below.

Vari-drive syncrogear – 80/100 S.U.V. Sec. at 210 Deg. F. or SAE 50 Motor Oil (Vari-O-Speed Model).

Syncrogear – 500/650 S.U.V. Sec. at 100 Deg. F. or SAE 30 Motor Oil (Std. Model)

Change oil after first week and twice yearly thereafter.

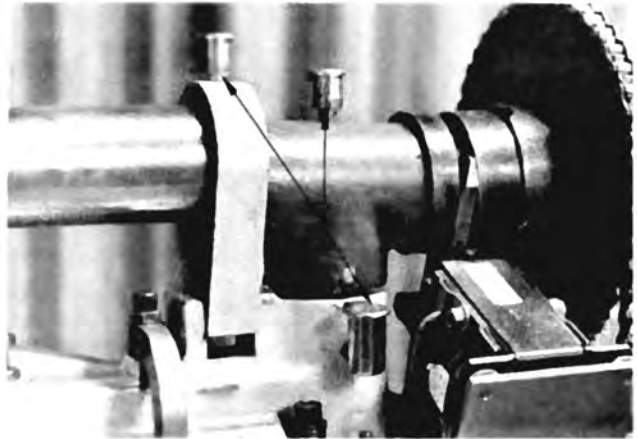

Figure 1

RECOMENDEND LUBRICANTS

MFG.

American Oil Co.
Atlantic Richfield Co.
Cities Service Oil Co.
Gulf Oil Corp.
Exxon Co.
Mobil Oil Co.
Phillips Petroleum Co.
St. Oil Co. of Calif. Inc.
Std. Oil Co. of Ohio
Sun Oil Co.
Texaco, Inc.
Union Oil of Calif.
Valvoline Div. Ashland
Oil, Inc.

500/600 S.U.V. Sec. @ 100 DEG. F.

Rykon Ind. Oil 51
Duro S-600
Citgo Pacemaker T-50
Harmony 69
Teresstic 65
DTE Oil Heavy-Med.
Magnus Oil 465
Chevron OC Turbine
Oil No. 19
Industron 66
Sunvis 951
Regal F (R& O)
Red Line Turbine 650
Valvoline ETC 70

80/100 S.U.V. Sec. @ 210 DEG. F.

Rykon Ind. Oil 150
Duro S-1000
Citgo Pacemaker T-100
Harmony 97
Teresstic 85
DTE Oil BB
Magnus Oil 1000
Chevron DC Turbine
Oil No. 36
Industron 100
Sunvis 999
Regal H (R & O)
Red Line Trubine 1000
Valvoline ETC 100

Operating procedures are the same for the standard power shear and the Vari-O-Speed Model.

SAFETY REMINDERS

CAUTION: Never operate machine without all protective guarding in place. Guards are located on all pinch points. The material holddown protects the operator from shear blade when machine is in operation. The hood that encloses the clutch should only be removed for maintenance.

OPERATOR CONTROLS (Fig. 2)

The keyed selector switch allows supervised control of the operating mode.

Single Stroke Operation—requires the release of the footswitch at the end of each cycle in order to initiate another shearing stroke.

CONTINUOUS OPERATION

In this mode, the shearing cycle is continuous. The shearing stroke speed on the Vari-O-Speed model can be varied to allow for material feed. Once the shear speed cycle has been dialed in on the adjusting handle, the operator simply feeds materials into the shear.

FOOTSWITCH CONTROL

Depressing the footswitch initiates the cutting stroke.

CHANGING SHEARING SPEED

When changing shearing rate, the motor should always be running. Turn adjusting handle (Fig. 3) until desired speed is achieved.

Do not attempt to change speed when motor is not running or damage to drive motor will result.



Figure 2

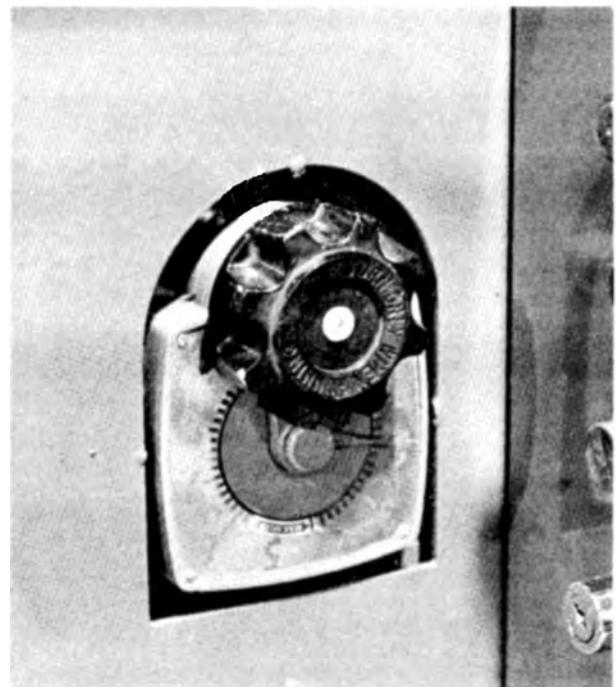

Figure 3

Both shear models are built to eliminate the necessity of adjusting the shear blades after they have been bolted into position against the base and top blade casting.

When shipped from the factory, these machines are adjusted to accurately shear 16 gauge steel and the thinnest of sheet materials.

The bottom shear blade should, at all times, be located so that its upper edge is flush with the top of the base casting and shear table.

ADJUSTING THE BRAKE

The brake on the eccentric shaft is set to stop the blade on "top center." After continued use, it may be required to readjust to prevent blade from falling ahead. To adjust, tighten screw until blade stops on top (Fig. 4). Do not over tighten!

Correct brake adjustment is achieved with the minimum clamping on brake adjustment screw necessary to stop the ram at top center of the stroke. Excessive tightening causes excessive wear on the brake lining, release lever, and clutch key.

ADJUSTING THE RELEASE LEVER

The release lever pulls the clutch dog from the flywheel by a wedging action against the clutch. After pulling the dog from the flywheel. The spring on the tail of the release lever pulls the dog farther out, preventing it from riding on the drive pins and causing a "clicking" sound.

To adjust the tension on this spring, insert a hex key wrench thru the hole in the release lever (Fig. 5) and adjust until lever is held away from the flywheel side of the clutch slot.

Excessive bind in the machine can cause the release lever to push away instead of pulling the key. **CHECK FOR EXCESSIVE BINDING BEFORE ADDING ADDITIONAL PRESSURE ON THE RELEASE LEVER SPRING!**

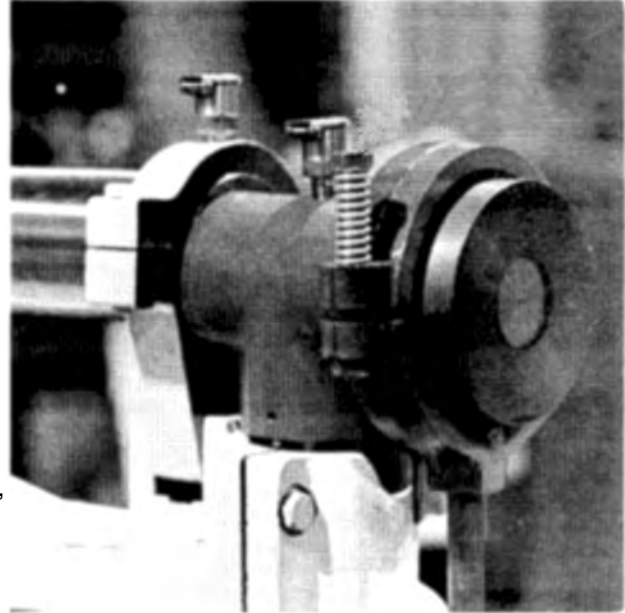

Figure 4

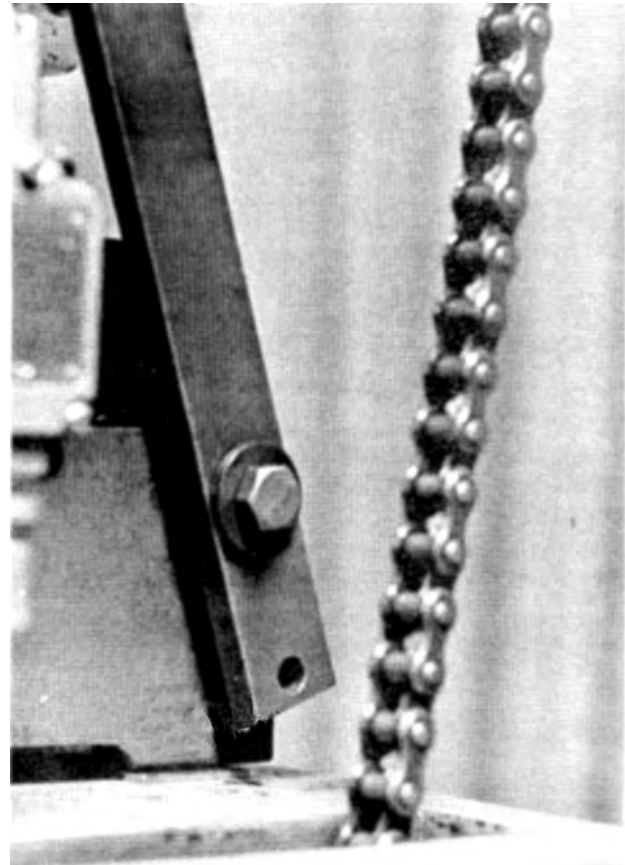

Figure 5

ADJUSTING "QUICK-SET" MICROMETER GAUGES

1. Set both micrometer nuts on zero. Push down on nut, releasing it from screw.
2. Move material stop to desired location while nut is depressed. (Within .050)
3. Release nut and turn to final dimension required.

SOLENOID PULL

The solenoid should pull far enough to release the key from the release lever. It also should "Bottom Out." If it does not "Bottom Out," it will hum. This indicates excessive bind or excessive spring pressure. Check spring pressure.

MODIFICATIONS

Do not attempt to modify this machine to exceed its rated capacity.

Any modification should be done with the manufacturer's approval, and at the manufacturer's facility.

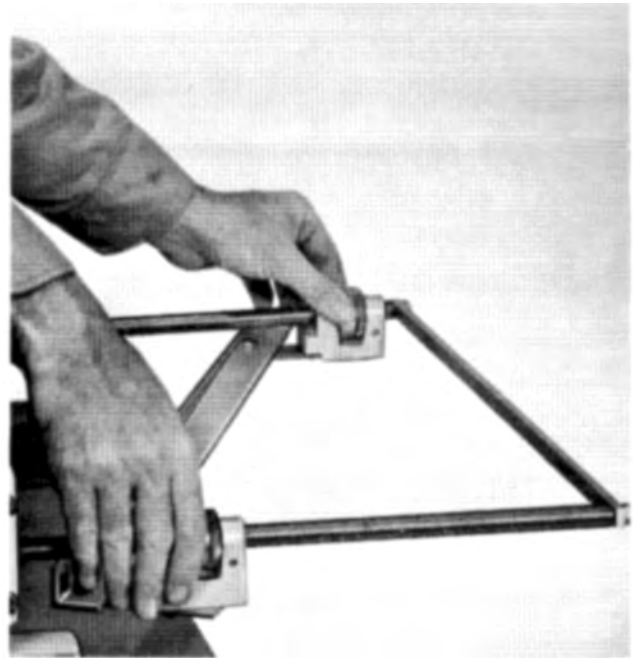

BLADE SHARPENING

When sharpening blades, never grind on the sides of the blade. The side of the blade is the widest dimension (Fig. 6). The blade thickness must always remain .470". If the thickness of the blade is reduced, it would be necessary to shim the blade to maintain proper clearance (Blade clearance is .002 to .004).

When installing the blade after sharpening, adjust backup screws under the blade, until blade is flush with the table height (Fig. 7)

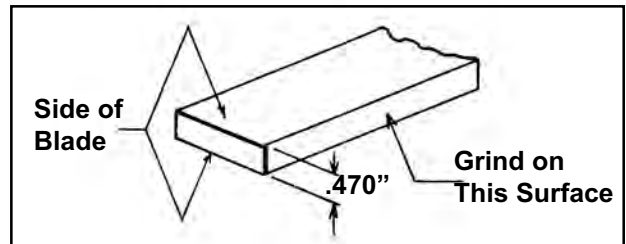

Figure 6

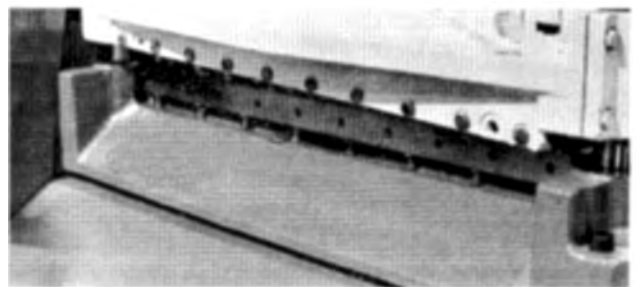

Figure 7

**READ
ORDERING POWER SHEAR
PARTS**

When ordering from Di-Acro parts manual, specify machine, part number, description, and quantity required.

To locate and identify the required part:

1. Refer to the Table of Contents for Identification of Group or Assembly Page Number.
2. Locate the Part in the Illustration by its Item Number and Match this with the Item Number in the Parts List. (USE PART NUMBER, NOT ITEM NUMBER, WHEN ORDERING)

IDENTIFYING UNNUMBERED PARTS

When ordering any unnumbered parts identify them by referring to the numbered part of which they are a component, or with which they are used.

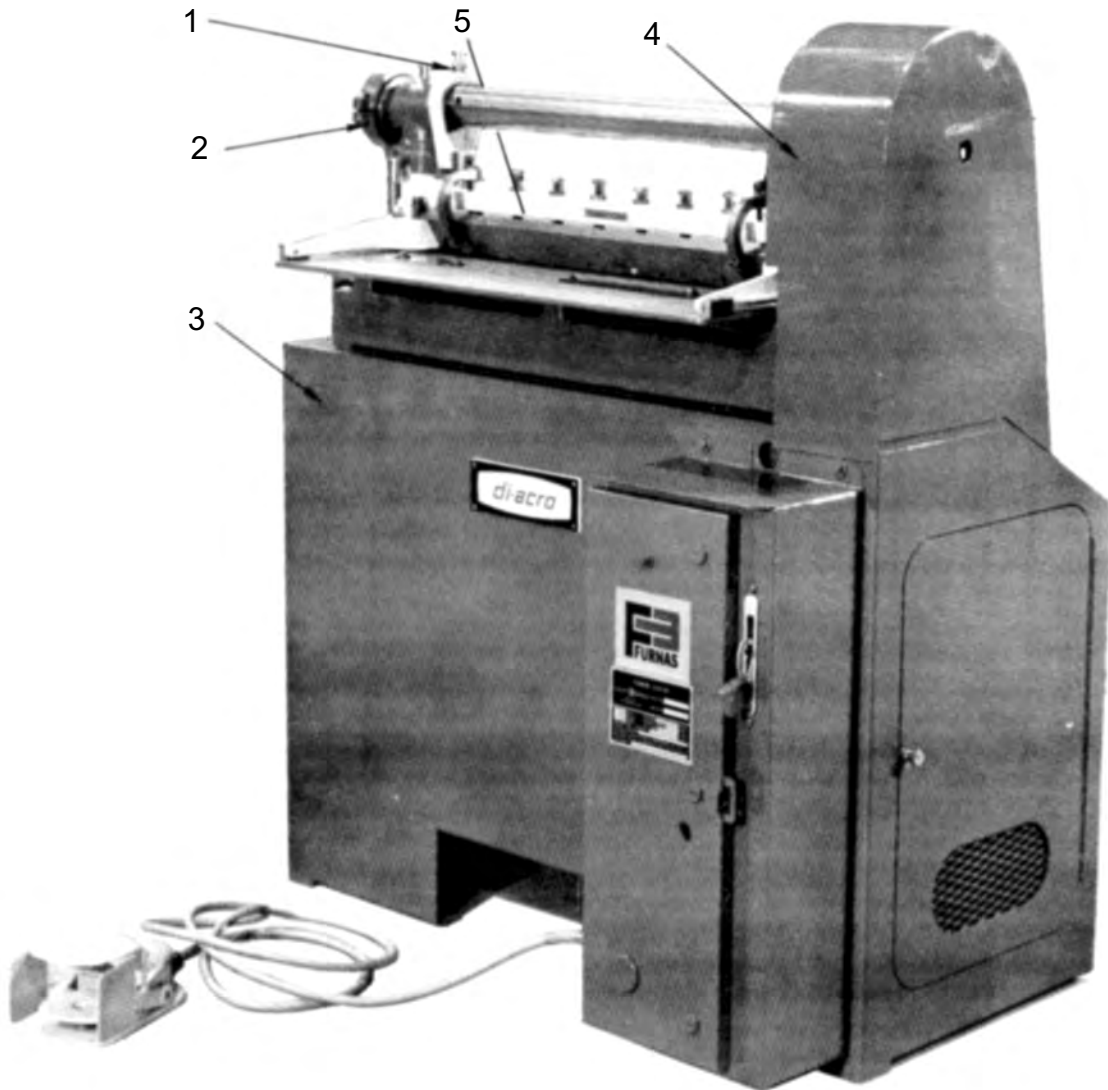

NOMENCLATURE

Item No.	Part No.	Description	Page No.
1	270-1200701	Shear Assembly	10,11,12
2	270-1207710	Brake Shoe Assembly	12
3	270-1109701	Base Assembly (Std)	13
	279-1109701	Base Assembly (Vari-O-Speed)	13
4	270-1206701	Clutch Linkage	14
5	270-1431796	Quik-Set Backgauge	15
		Dial Nut Assembly	16

SHEAR ASSEMBLY

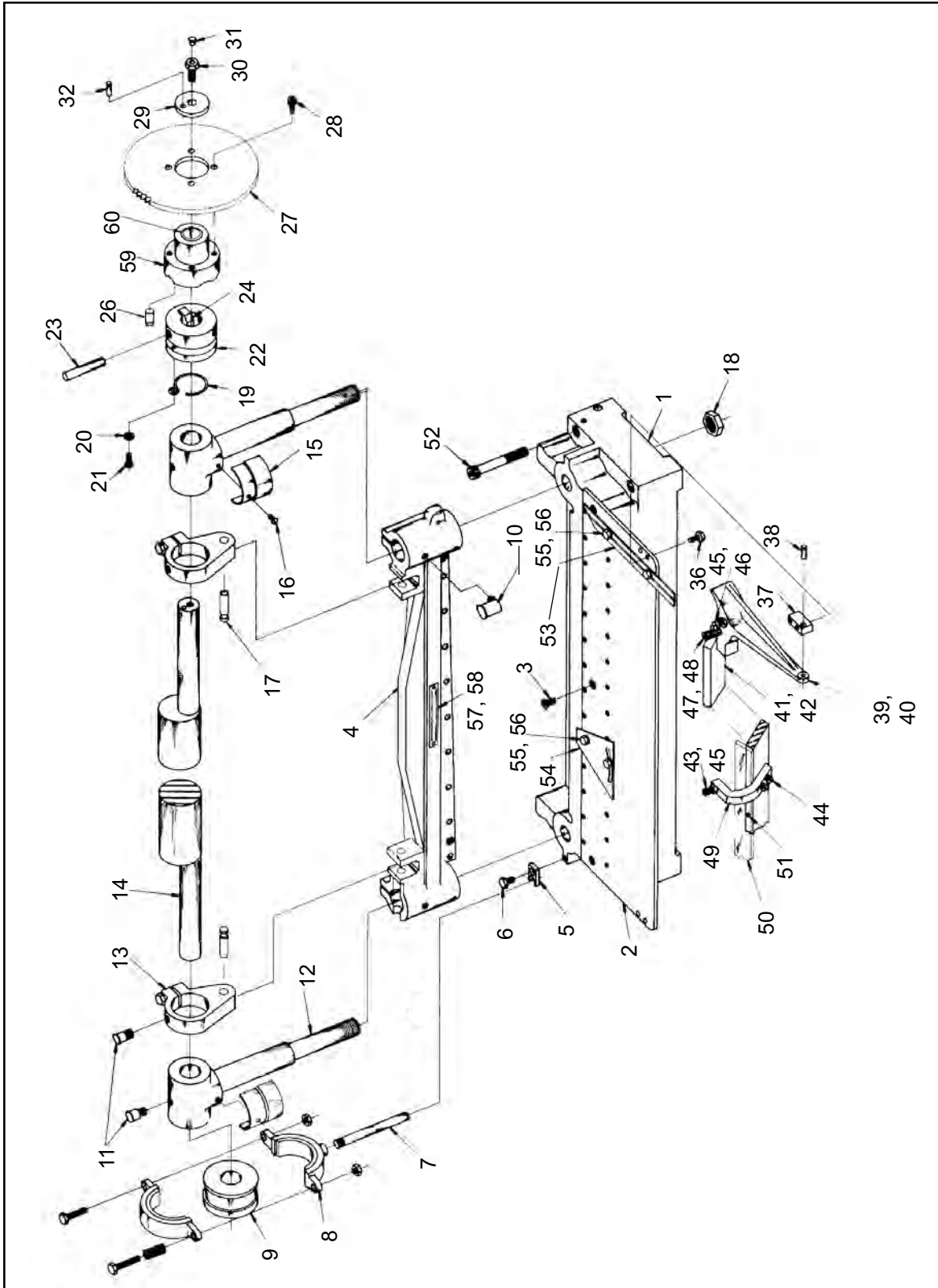

SHEAR ASSEMBLY

Item No.	Part No.	Description	Qty Used
1	270-1101002	Base Casting	1
2	240-1105013	Table	1
3	20C0104C0102	Flat Hd Soc Cap Scr	3PP
4	270-1213003	Upper Casting	1
5	270-1108057	Brake Rod Stop	1
6	21A0561C0508	Hex Hd Cap Scr	1PP
7	270-1207056	Brake Rod	1
8	270-1207710	Brake Shoe Assy	1
9	270-1207054	Brake Collar	1
10	6901007	Oil Cup	2PP
11	6901008	Oil Cup	4PP
12	270-1103712	Shaft Bearing Assy	2
13	270-1212006	Shaft Link	2
14	270-1211005	Shaft	1
15	270-1106003	Guard	2
16	22AXX08C0102	Rd Hd Mach Scr	2PP
17	230-1203009	Pin	2
18	31X1000F	Jam Nut	2PP
19	250-5103040	Clutch Spring	1
20	4901103	Flat Washer	1PP
21	22A0104C0102	Rd Hd Mach Scr	1PP
22	250-1206038	Clutch	1
23	1203104	Dowel Pin	1PP
24	250-1206039	Clutch Dog	1
26	250-1203074	Drive Pin	4
27	270-5301032	Sprocket	1
28	20A0516C0508	Soc Hd Cap Scr	4PP
29	250-4901067	Shaft Washer	1
30	250-4701051	Shaft Oil Bolt	1
31	6901001	Oil Cup	1PP
32	1203105	Dowel Pin	1PP
33	4301903	Chain (not shown)	4PP
34	4302009	Offset Connect Link (not shown)	1PP
35	4302004	Connecting Link (not shown)	1PP
36	21A0104C0708	Hex Hd Cap Scr	4PP
37	251-1219011	Hold Down Trunnion	2
38	1203101	Dowel Pin	2PP
39	251-1219009	Hold Down Arm R	1
40	251-1219010	Hold Down Arm L	1
41	271-1219108	Hold Down Bar	1
42	20A0516C1000	Soc Hd Cap Scr	4PP
43	20A0516C1102	Soc Hd Cap Scr	2PP
44	20A0104C1000	Soc Hd Cap Scr	4PP
45	31X0516C	Jam Nut	4PP
46	251-4701015	Arm Adj Bolt	2PP
47	20A0308C3102	Soc Hd Cap Screw	2
48	5102117	Spring	2PP
49	271-1217012	Hold Down Bracket	2
50	270-1106005	Hold Down Guard	1

SHEAR ASSEMBLY CONT

Item No.	Part No.	Description	Qty
51	22AXX06C0308	Rd Hd Mach Scr	6PP
52	20A0102C3102	Soc Hd Cap Scr	4PP
53	250-1601084	Squaring Gage	1
54	230-1435026	Protractor Gage	1
55	21A0104C0308	Hex Hd Cap Scr	4PP
56	4901102	Flat Washer	4PP
57	030-6503105	Instruction Plate	1PP
58	29AXXX0X0108C	Drive Screw	2PP
59	270-5301731	Hub Assy	1
60	056-3106092	Bearing	1

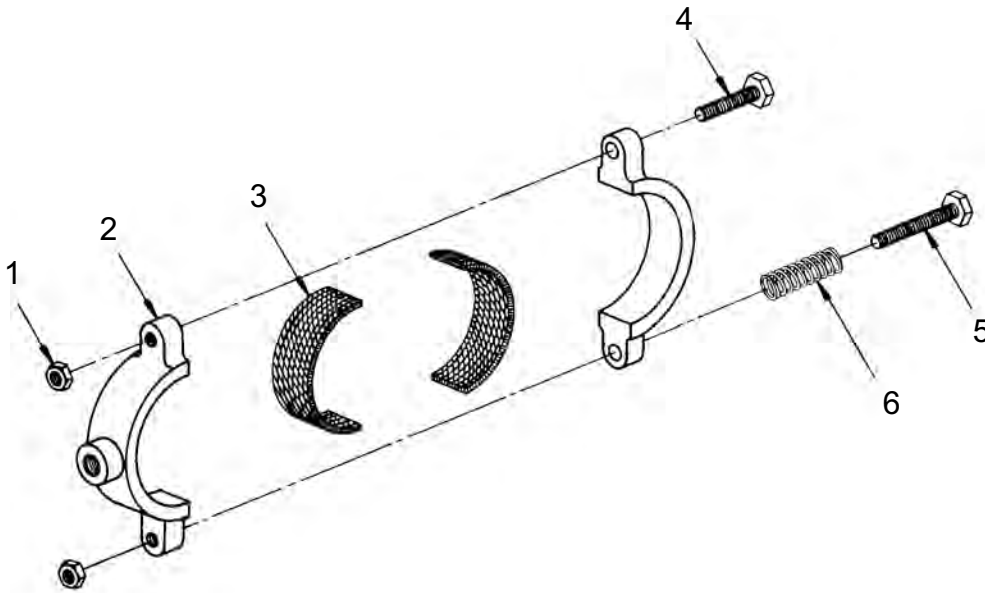

BRAKE SHOE ASSEMBLY

Item No.	Part No.	Description	Qty
1	31X0516C	Jam Nut	2PP
2	270-1207055	Brake Shoe	1
3	270-1207001	Brake Lining	2
4	4701137	Hex Hd Cap Scr	1PP
5	4701112	Hex Hd Cap Scr	1PP
6	5102110	Spring	1PP

BASE ASSEMBLY

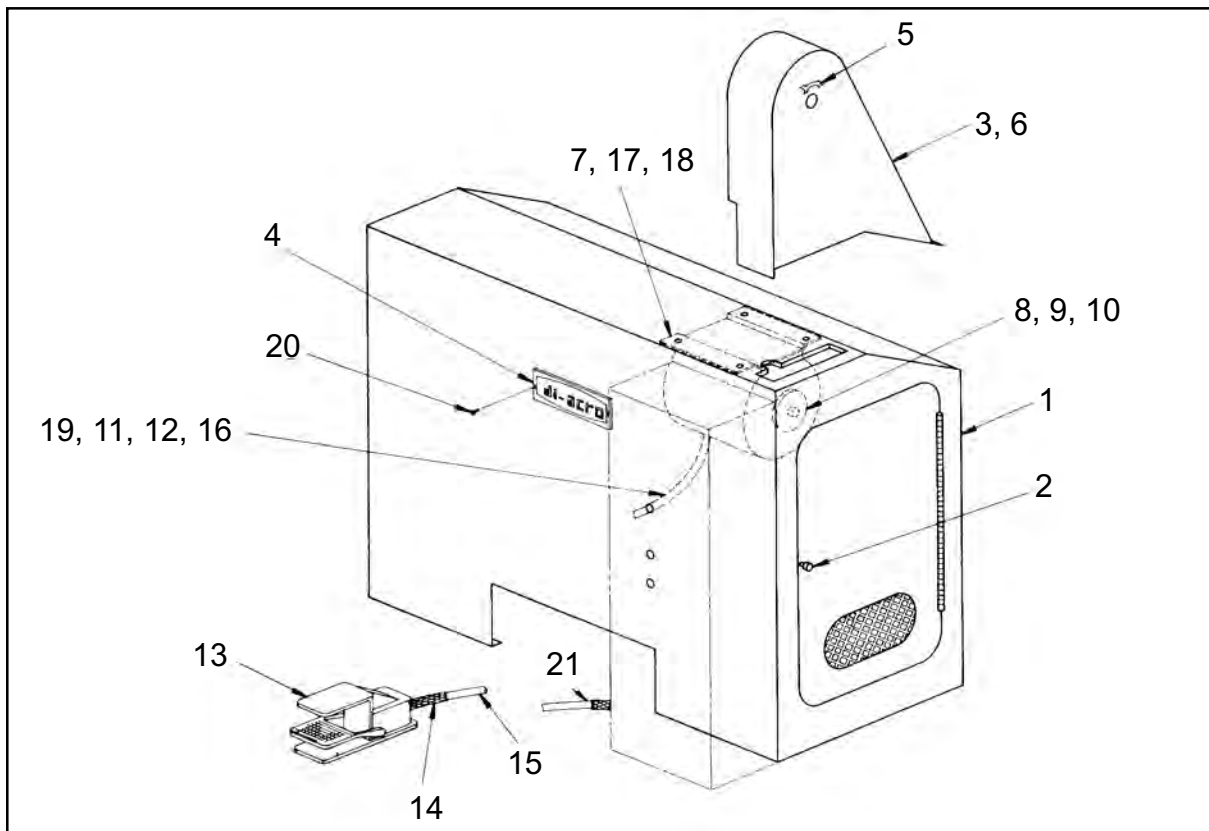

Item No.	Part No.	Description	Qty
1	270-1109013	Cabinet	1
2	4701147	Panel Screw	1PP
3	270-1106004	Chain Guard	1PP
4	035-6502005	Nameplate	1PP
5	032-6503018	Arrow Plate	1PP
6	21AXX10C0102	Hex Hd Cap Scr	4PP
7	3301068	Motor— Standard Shear	1
	3301078	Motor—Vari-O-Speed	1
8	270-5301034	Sprocket—Standard Shear	1
	279-5301082	Sprocket—Vari-O-Speed	1
9	23A0516C0308	Soc Set Scr	2PP
10	5501112	Key	1PP
11	3314907	St Cond	2PP
12	3316905	Wire, Black	6PP
13	3303002	Footswitch	1PP
14	3315112	Deluxe Cord Grip	1PP
15	3316901	Cord	4PP
16	3315080	Connector	1PP
17	21A0308C0508	Hex Hd Cap Scr	4PP
18	4902008	Lock Washer	4PP
19	3315162	Conn 1/2 St	1PP
20	26GXX04C0516C	Ov Hd Thd Cut Scr	4PP
21	3315210	Deluxe Cord Grip	1PP

CLUTCH LINKAGE

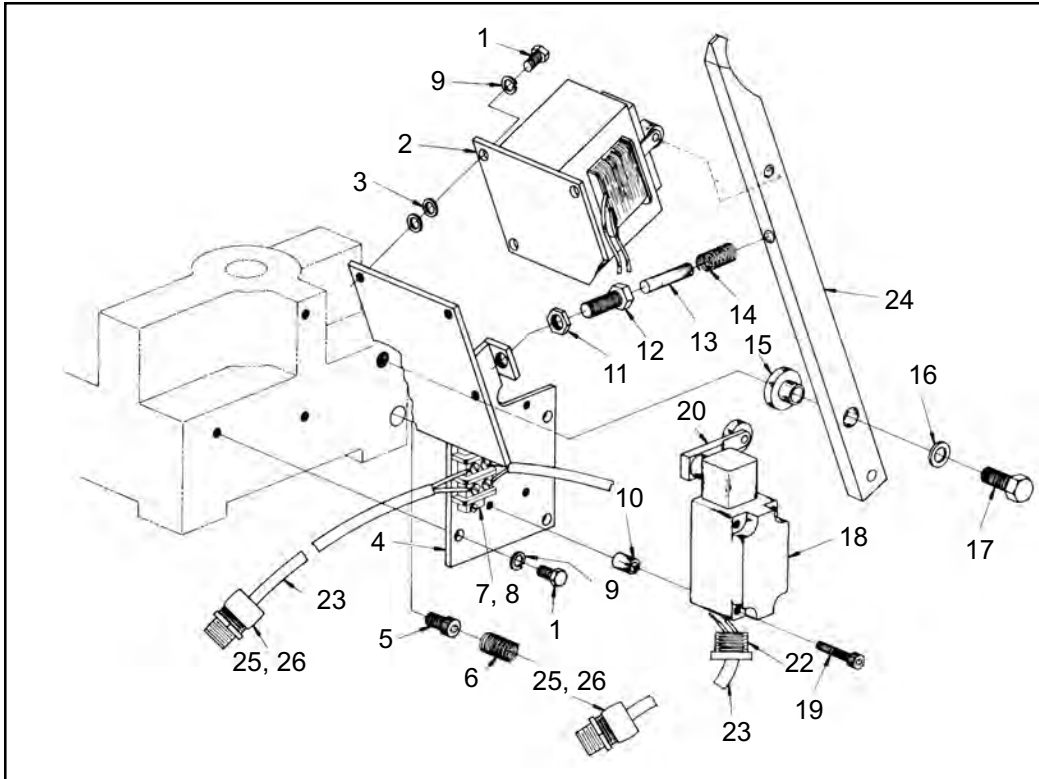

Item No.	Part No.	Description	Qty
1	21A0104C0508	Hex Hd Cap Scr	7PP
2	3306018	Solenoid	1PP
3	61X0104	Washer Flat	8PP
4	270-1110032	Sol Mtg Wldmt	1
5	20A0516C0102	Sod Hd Cap Scr	1PP
6	5102102	Spring	1PP
7	3308127	Terminal Strip	1PP
8	22AXX06C0102	Rd Hd Mach Scr	2PP
9	62X0104	Lock Washer	7PP
10	065-1108000	Spacer	4
11	31X0308C	Jam Nut	1PP
12	270-1323001	Tension Screw	1
13	1203188	Dowel Pin	1PP
14	5102110	Spring	1PP
15	250-1108069	Link Spacer Sleeve	1
16	61X0308	Flat Washer	1PP
17	21A0308C1000	Hex Hd Cap Scr	1PP
18	3305016	Limit Switch	1PP
19	22BXX10C1304	Fill Hd Mach Scr	4PP
20	3305050	Actuator	1PP
22	3305001	Microswitch Kit	1PP
23	3316913	Cord	4PP
24	270-1301150	Release Lever	1
25	3315111	Cord Grip	2PP
26	3315116	Bushing	2PP

QUICK-SET BACKGAGE

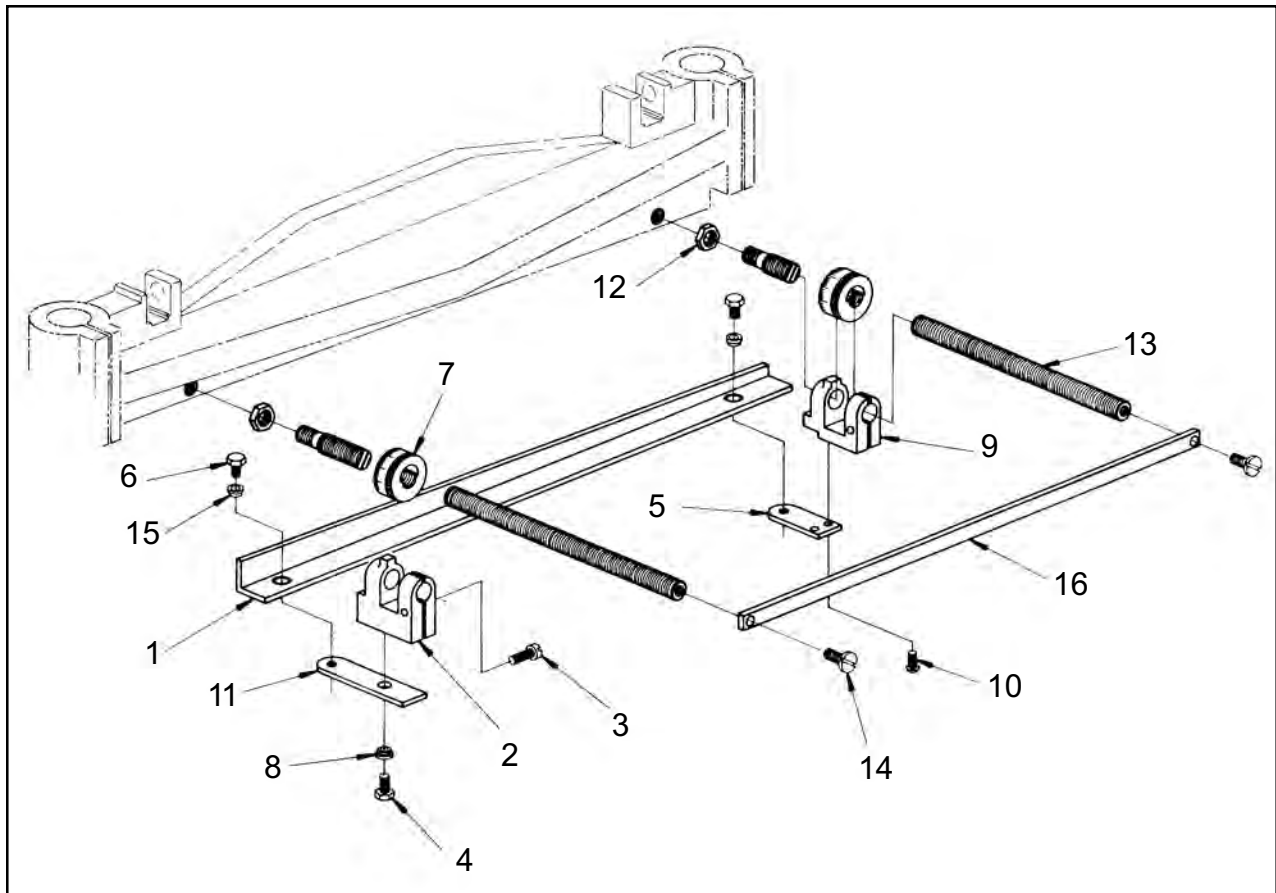

Item No.	Part No.	Description	Qty
1	270-1431036	Quik-Set Stop	1
2	210-1431038	Bracket	1
3	22B0104C0708	Fill Hd Mach Scr	2PP
4	21A1014C0102	Hex Hd Cap Scr	1PP
5	210-1431041	Quik-Set Arm Short	1
6	21A0104C0308	Hex Hd Cap Scr	2PP
7	210-1431720	Dial Nut Assy	2
8	210-1431046	Pivot Sleeve	1
9	220-1431038	Bracket	1
10	22AXX10F0102	Rd Hd Mach Scr	2PP
11	220-1431040	Quik-Set Arm Long	1
12	690-4704045	Lead Screw Nut R	2
13	230-1431039	Quik-Set Rod	2
14	22D516C0102	Truss Hd Mach Scr	2PP
15	240-1431047	Pivot Sleeve	2
16	240-1431050	Quik-Set Tie Bar	1

DIAL NUT ASSEMBLY

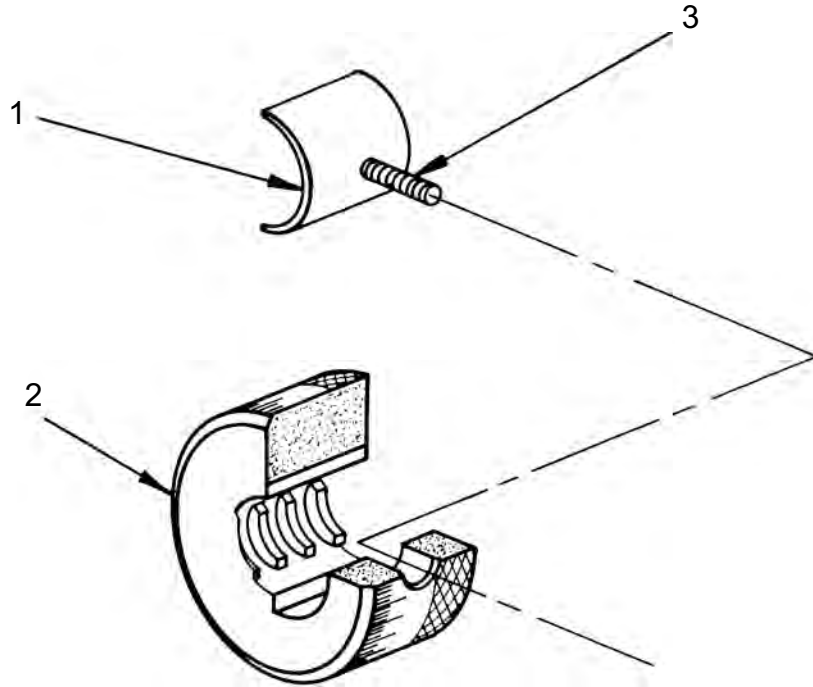

Item No.	Part No.	Description	Qty
1	210-1431043	Quik-Set Dial Shoe	1
2	210-1431042	Quik-Set Dial Nut	1
3	210-5102048	Spring	1