

DI-ACRO #24 HAND SHEAR INSTRUCTION MANUAL



DiAcro[®]
METAL FABRICATION EQUIPMENT

579 Schommer Dr - Ste C

Hudson, WI 54016

Phone: 651.342.1756

Email: info@diacro.com

TABLE OF CONTENTS

SAFETY INFORMATION	PG. 3
SET UP PROCEDURE	PG. 3
MAINTENANCE	PG. 3
TECHNICAL DATA	PG. 3
OPERATING PROCEDURES	PG. 4
INSTALLING QUIK-SET MICROMETER GAUGES	PG. 5
INSTALLING HOLDDOWN BAR ASSEMBLY	PG. 6
PARTS LIST	PG. 7-8
HOLDDOWN ASSEMBLY PARTS LIST	PG. 9
QUIK-SET GAUGE ASSEMBLY PARTS LIST	PG. 10
STAND	PG. 11
WARRANTY	PG. 12

SAFETY INSTRUCTIONS



Before Shear is set up for operation, mount on work bench or stand*.

*IF SHEAR IS MOUNTED ON ITS OWN STAND, SECURE STAND TO FLOOR.

SET-UP PROCEDURE

Mount the Protractor Gauge on the Table with the Gauge screws.

Insert Handle in Holder and tighten in place.

TECHNICAL DATA

SPECIFICATIONS

Model #24 Hand Shear	in.	mm
Max. Shearing Width	24	609.6
Max. Capacity, m.s.	16 ga.	1.5
Range of Back Gauge	12	304.5
Shipping Weight	290 lbs.	131 kg.

OPERATING INSTRUCTIONS

When setting up for a production run:

1. Mount the Ruled Squaring Gauge or the Protractor Gauge in the most practical position on the work table and adjust it to the desired angle. (See Illustration A)
2. Mount and position Material Gauge as described on the following page.

MAINTENANCE

Lubricate as needed.

Adjusting Shear Blades:

The precision standards to which Di-Acro Shears are built eliminate the necessity of adjusting the shear blades after they have been bolted into position against the base and top blade casting.

When shipped from the factory, these machines are adjusted to accurately shear 16 gauge steel and the thinnest of sheet materials.

The bottom shear blade should at all times be located so that its upper edge is flush with the top of the base casting and the shear table.

Vertical adjustment of the bottom shear blade is obtained by use of Blade Support bolts which are located in the base casting directly below the bottom blade (See Illustration B)

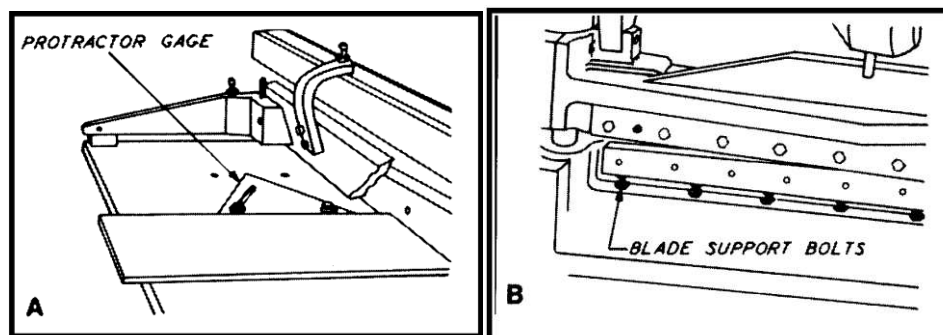

Sharpening Shear Blades:

Di-Acro shear blades are made from high quality oil hardened tool steel properly heat treated and precision ground. They are easily resharpened on an ordinary surface grinder by grinding the narrow edge of the blade which measures .470" (See Illustration C)

NOTE: Grinding the wide edge of the blade reduces its size and necessitates shimming to obtain proper adjustment.

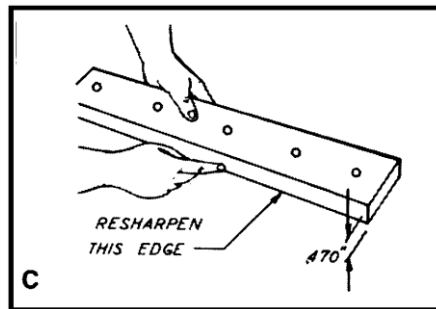

QUIK-SET MICROMETER BACK GAUGE

NOTE: Shear ships with Quik-Set Micrometer Gauge assembled.

Installation Steps are below:

1. Mount Material Stop C on Micrometer Gauges D and E.
2. Screw in Threaded Rods A & B by hand until they stop. Make sure lock nuts are loose.
3. Synchronize gauges.

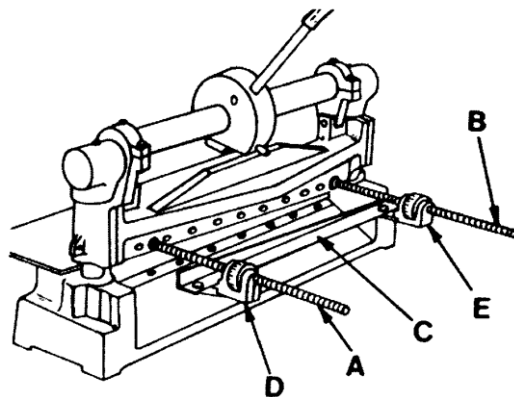

To Synchronize Gauges:

1. Set Micrometer Gauges D and E on Zero.
2. Push down or depress spring loaded Micrometer Gauges to release them from the Threaded Rods and slide Material Stop Assembly forward until it touches lower shear blade.
3. Turn Micrometer Gauges D and E to engage Threaded Rods.
4. Turn Threaded Rods A and B counterclockwise and Micrometer Gauges D and E clockwise until Material Stop C touches lower shear blade and Micrometer Gauges read zero.
5. Tighten lock nut on each Threaded Rod.

Adjusting Quik-Set Micrometer Gauge

Operator can easily and quickly adjust the Gauge while standing either in front or in back of shear.

1. Set both Micrometer Dial Nuts on zero and push down or depress. This releases the Material Stop Assembly from the Threaded Rods.
2. Move Material Stop to approximate desired location (complete assembly can be freely moved back and forth on Threaded Rods when Dial Nuts are depressed) and adjust the Dial Nuts to accurately position Material Stop.

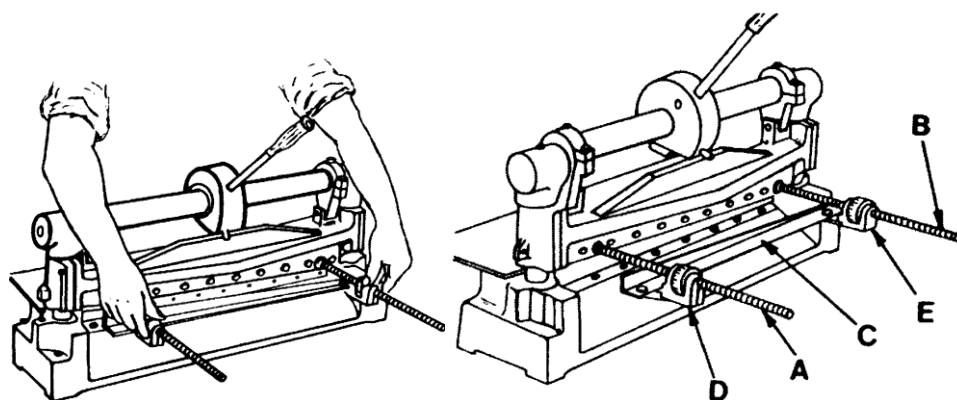

HOLDDOWN ASSEMBLY

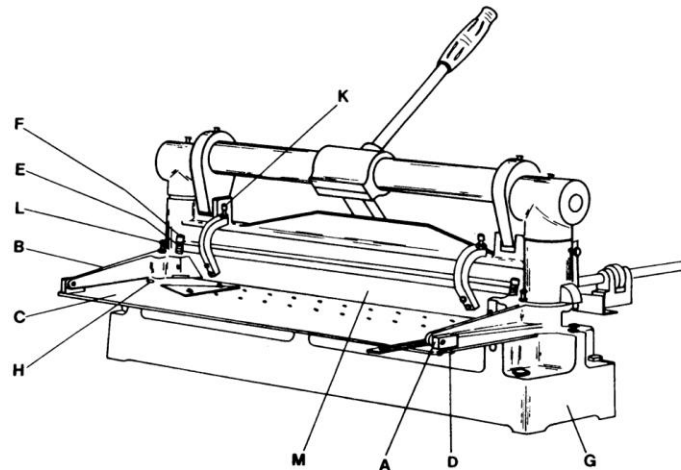

Installation Steps:

1. Mount Shear Table C on Casting with Screws H.
2. To mount basic Holddown Assembly, screw Holddown M to Holddown Arms B using socket head cap screws provided.
3. Place Holddown Assembly on Shear Table centering Bolts D in oversize holes.
4. Mount Holddown Assembly on Shear Table locating Springs E on Screws F and starting them into tapped holes in base casting.
5. Locate front edge of Holddown M at edge of lower shear blade so it may be used as gauge when shearing to a scribed line. Horizontal adjustment of the Holddown Bar is provided for by the oversized mounting holes for Holddown trunnions A.
6. Adjust vertical clearance of Holddown Bar on Screws K. For accuracy, when shearing to a scribed line, it is important that both vertical and horizontal adjustments be made so that the bar is very close to the material being sheared.
7. Regulate tension of Holddown Bar by adjusting Holddown Spring Screws F. Adjust to minimum tension required to securely hold material while shearing. When shearing narrow strips of material on one end of the shear, two ways assuring even hold down pressure across the material are:
 8. Place a piece of the material between the Holddown Bar and the table on the opposite end.
 9. Adjust Screw L on the opposite end to a point where a material thickness is the distance between the Holddown Bar and the Table.

#24 HAND SHEAR PARTS BREAKDOWN 82418000-080

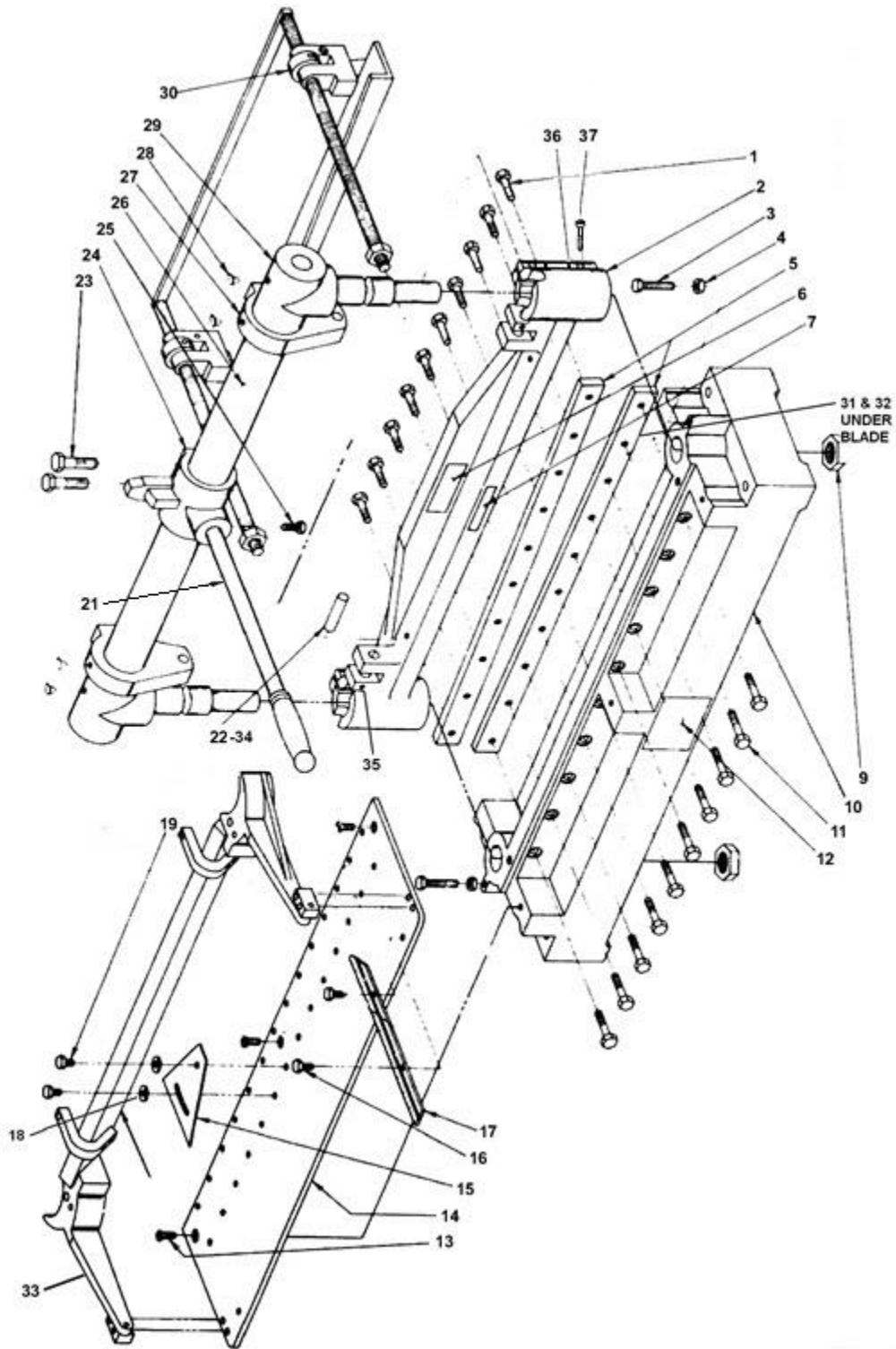

**PARTS LIST
8241800-080**

ITEM	PART NUMBER	DESCRIPTION	QTY
1	21A0516C1104	SCREW-HHCS 5/16-18X1-1/4	10
1A	61X0516	WASHER-FLAT 5/16	10
2	8240121-300	UPPER CASTING	1
3	21A0516C1104	SCREW-HHCS 5/16-18X1-1/4	2
4	31X0516C	NUT-JAM 5/16	2
5	8240120-900	BLADE	2
6	8150650-110	NAMEPLATE	1
7	8030650-301	LABEL-PINCH POINT	1
9	31X1000F	NUT-JAM 1	2
10	8240110-100	BASE	1
11	21A0516C1304	SCREW-HHCS 5/16-18X1-3/4	10
11A	61X0516	WASHER-FLAT	10
12	030-6503001	CAUTION PLATE	1
13	20C0104C0508	SCREW-FHSCS 1/4-20X5/8	3
14	8240110-501	TABLE	1
15	8230143-502	PROTRACTOR GAUGE	1
16	20B0104C0308	SCREW-BHCS 1/4-20X3/8	2
17	8250160-108	SQUARING GAUGE	1
8	61X0104	WASHER-FLAT 1/4	2
19	20B0104C0308	SCREW-BHCS 1/4-20X3/8	2
21	8991120-800	HANDLE	1
21A	100-0142-M	HANDLE GRIP	1
22	8230120-300	PIN	2
23	20A0102C1304	SCREW-SHCS 1/2-13X1-3/4	2
24	8240120-801	HANDLE HOLDER	1
25	23A0104C0102	SCREW-SSS 1/4-20X1/2	1
26	8240121-100	SHAFT	1
27	8240121-200	SHAFT LINK	2
28	8690100-100	OIL HOLE COVER	4
29	8240110-371	SHAFT BEARING ASSEMBLY	2
	8230110-300	BEARING	2
	8240110-301	POST	2
30	8240143-179	QUIKSET BACKGAUGE ASSY (SEE PAGE 10)	1
31	21A0104C1104	SCREW-HHCS 1/4-20X1-1/4(NOT SHOWN)	8
32	31X0104C	NUT-JAM 1/4-20 (NOT SHOWN)	8
33	8271121-971	HOLDDOWN ASSY (SEE PAGE 9)	1
34	22D0104C0308	SCREW-THMS 1/4-20X3/8	2
35	23A0X10C0308	SCREW-SSS #10-24X3/8	2
36	23A0104F0102	SCREW-SSS 1/4-28X1/2	4
37	20A0516C1104	SCREW-SHCS 5/16-18X1-1/4	4

HOLDDOWN ASSEMBLY - #8271121-971

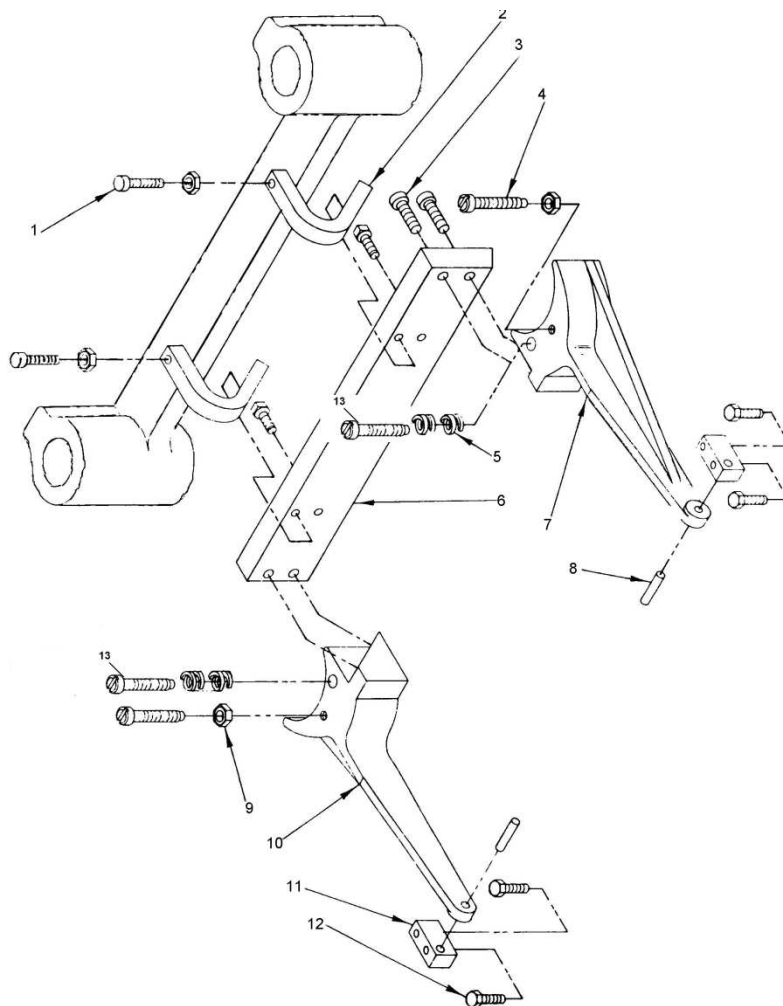

ITEM	PART NUMBER	DESCRIPTION	QTY
1	20A0516C1104	SCREW-SHCS 5/16-18X1-1/4	2
1A	31X0516C	NUT-JAM 5/16-18	2
2	8271121-701	HOLDDOWN BRACKET	2
3	20A0516C1000	SCREW-SHCS 5/16-18X1	4
4	8251470-101	ARM ADJ BOLT	2
5	8510211-700	SPRING	2
6	8240121-900	HOLDDOWN BAR	1
7	8251121-900	HOLDDOWN ARM "R"	1
8	19A0104X1000	PIN-DOWEL 1/4X1	2
9	31X0516C	NUT-JAM 5/16-18	2
10	8251121-901	HOLDDOWN ARM "L"	1
11	8000121-901	HOLDDOWN TRUNNION	2
12	20A0104C1000	SCREW-SHCS 1/4-20X1	8
13	20A0308C3000	SCREW-SHCS 3/8-16X3	2

BACKGAUGE ASSEMBLY 8240143-179

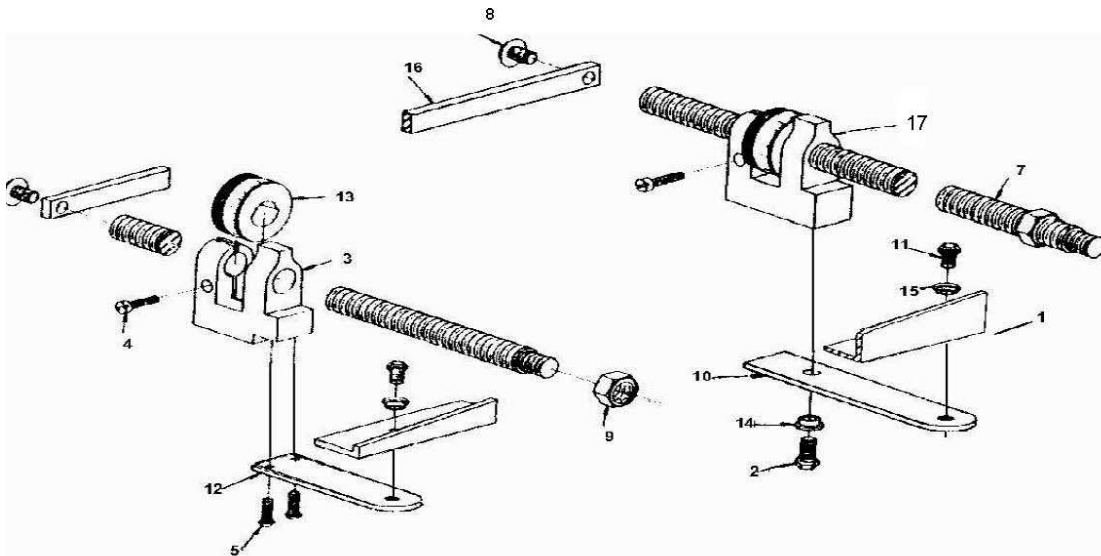

PARTS LIST

ITEM	PART NUMBER	DESCRIPTION	QTY
1	8240143-103	QUIK SET STOP	1
2	21A0104C0102	SCREW-HHCS 1/4-20X1/2	1
3	8000143-103	QUIK SET BRACKET "L"	1
4	22B0104C0708	SCREW-FHMS 1/4-20X7/8	2
5	22A0X10F0308	SCREW-RHMS #10-32X3/8	2
7	8230143-103	QUIK SET ROD	2
8	22D0516C0102	SCREW-THMS 5/16-18X1/2	2
9	8690470-404	NUT	2
10	8241143-104	QUIK SET ARM BENT	1
11	21A0104C0308	SCREW-HHCS 1/4-20X3/8	2
12	8100143-104	QUIK SET ARM SHORT	1
13	8210143-172	DIAL NUT ASSY	2
	8210510-204	SPRING	2
	8000143-104	DIAL SHOE	2
	8210143-104	DIAL NUT	2
14	8200143-104	PIVOT SLEEVE	1
15	8010143-104	SPACER SLEEVE	2
16	8240143-105	QUIK SET TIE BAR	1
17	8130143-103	QUIK SET BRACKET "R"	1

OPTIONAL STAND PART NUMBER IS 8346110-900

STAND DIMENSIONS ARE 38" WIDE, 15" DEEP, 33-1/4" HIGH

CALL DI-ACRO FOR PRICE AND AVAILABILITY



Fasteners needed to attach Shear the stand are the following:

(Fasteners to attach stand to floor are not included.)

PART NUMBER	DESCRIPTION	QTY
21A0102C4102	SCREW-HHCS 1/2-13X4-1/2	4
61X0102	WASHER-FLAT 1/2	4
30X0102C	NUT-FULL 1/2-13	4

Warranty & Limitation of Liability

Defective parts, of a product manufactured by DI-ACRO, will be replaced or repaired at no charge for twelve (12) months following delivery to the original purchaser. Labor is included for the first 90 days. This warranty becomes void when products have not been used according to instructions furnished by DI-ACRO, nor does it cover any altered parts or unauthorized repairs. We cannot be responsible for the cost of repairs made or attempted outside of our factory. All other warranty claims are made FOB our plant, providing such items(s) is returned freight prepaid to our plant for examination.

This warranty does not apply to parts, components or systems not manufactured by DI-ACRO. These products are covered instead by the existing warranties, if any, of their manufacturers. Normal service items with a reasonable life expectancy of less than one year are warranted only to the extent of the reasonable life under normal use and service.

Authorization must be obtained from DI-ACRO before returning parts or equipment to the factory. DI-ACRO will satisfy this warranty by replacing the product or refunding the purchase price upon receipt, inspection and defect identification.

DI-ACRO's liability under this warranty shall not exceed the amount paid for the product.

THIS IS DI-ACRO'S SOLE WARRANTY IN LIEU OF ALL OTHER WARRANTIES, EXPRESS OR IMPLIED, WHICH ARE HEREBY EXCLUDED, INCLUDING IN PARTICULAR ALL WARRANTIES OF MERCHANTABILITY, FITNESS OR ANY LOSS, DAMAGE OR EXPENSES DIRECTLY OR INDIRECTLY RELATED TO THE USE OF ITS PRODUCT OR FROM ANY OTHER CAUSE OR FOR CONSEQUENTIAL DAMAGES INCLUDING, WITHOUT LIMITATION, LOSS OF TIME AND LOSS OF PRODUCTION.

IT IS EXPRESSLY UNDERSTOOD THAT DI-ACRO IS NOT RESPONSIBLE FOR DAMAGE OR INJURY CAUSED TO OTHER PRODUCTS, MACHINERY, PROPERTY OR PERSONS BY REASON OF THE USE OF ITS PRODUCTS.



579 Schommer Dr - Ste C

Hudson, WI 54016

Phone: 651.342.1756

Email: info@diacro.com