

**DiAcro**<sup>®</sup>

# #2 POWER OPERATED ROD PARTER

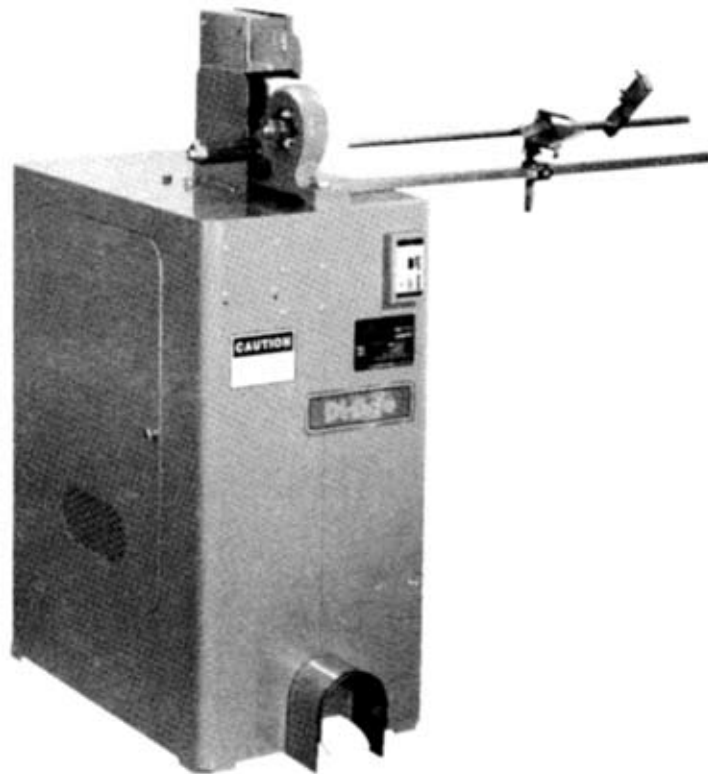

**DiAcro**<sup>®</sup>

METAL FABRICATION EQUIPMENT

579 SCHOMMER DR - STE C

HUDSON, WI 54016

(651) 342-1756 (P)

## **DISCLAIMER**

DI-ACRO by supplying this manual is not liable for any indirect, incidental, or consequential damages or injuries sustained or incurred in connection with using the information in any way contained herein.

DI-ACRO accepts no responsibility or liability resulting from attempts to use this information.

DI-ACRO does not vouch for or warrant the accuracy, completeness or usefulness of any information contained herein.

## POWER ROD PARTER

### Standard Equipment

One Material Length Gauge  
 Half horse power motor and electrical equipment.  
 One set of cutting heads for "parting-off" round cold rolled bar stock.

### Accessories

Cutting heads for "parting-off" square, rectangular, hexagon and other special shaped hot rolled bar stock.  
 Speed-Matic Gauge  
 Adjustable Stock Stand – designed especially for the Power Rod Parter. Valuable when feeding material at high rate of production.

**Speed-Matic Gauge** – indispensable when as extremely high rate of production must be maintained. No need to use the foot pedal – operator concentrates on feeding stock through the cutting heads against the Speed-Matic Gauge. This contact is relayed to a solenoid, which trips off the cutting action; cut apart is ejected in this same cycle. Depending upon the length of cut, it is possible to "part-off" several thousand pieces per hour with a Speed-Matic Gauge.

### Construction Features

The Di-Acro No.2 Power Rod Parter is equipped with cutting heads with nine holes graduated in size form 1/8" to 1/2" diameter in steps of 1/16"; this allows choice of cutting hole to exact material size. Cutting heads are made of heavy alloy tool steel 1" thick, properly hardened and precision ground for long wear and accuracy. Heads are reversible offering double service. They are easily removed for resharpener, and can be quickly reinstalled. Flywheel, clutch and other moving parts are housed in a welded steel cabinet for extra safety.

## DI-ACRO POWER PARTER Specifications and Capacities

Maximum Material Capacity – steel bar	1/2"
Cutting Head Thickness	1"
Weight of Flywheel	85 lbs.
Strokes per Minute	180
Standard Motor (Optional 110-220 Volt A.C. single phase, 230-460 Volt A.C. three phase)	1/2 H. P.
Motor Speed	1750 R.P.M.
Operating Height	40"
Floor Space	17" x 28"
Weight – Net	450 lbs.

**OPERATING INSTRUCTIONS****SET UP PROCEDURE****Power Rod Parter**

The power operated Di-Acro Rod Parter is shaped with the Material Length Gauge removed. To setup for operation, hookup wiring, install and adjust Material Length Gauge (see section on setting up Material Length Gauge).

**Wiring**

Cost of the Di-Acro Power Rod Parter includes wiring for either of the following standard electrical systems.

110 or 220 volt single phase / 60 Hz.

230 or 460 volt three phase / 60 Hz.

To setup for operation hook up lead-in wires and switch motor on to check direction of Flywheel. It should operate in a counter-clock-wise direction and indicated by the arrow on right Bearing Bracket. If the lead-in wires have been incorrectly hooked up, tripping mechanism will fail to operate and a clicking sound will be heard. To remedy this, reverse any two of the lead-in wires.

**Installing Material Length Gauge**

The Material Length Gauge on the Power Parter has been removed for shipment.

**To setup for operation:**

1. Remove cover located on top of Power Parter
2. Remove Stop Collar on Stop Rod.
3. Insert Stop Rod through Stop Rod Sleeve (Sleeve is already mounted in position on machine) so that Trip Clamp fits snugly against Sleeve and between Dowel Pins.
4. Place Stop Rod Collar on left side of Stop Rod and tighten.
5. Loosen Stop Arm mounted on Stop Rod and turn to approximate position opposite hole size of rod to be parted.
6. Mount Material Support Arm by positioning Material Support Bar on top of cabinet. Insert Dowel Pin (below Support Bar) and tighten bolt. The complete Stripper Support Assembly can be located at any point along the Support Bar. The exact positioning depends upon the length and type of material to be cut. Replace cover.

7. Insert material in hole nearest its own dimension. Push material against the Stock Rod Trigger so that the Trigger is snug against the Stock Arm.\*
8. Operate Power Parter by pressing Foot Pedal – cutting action is instantaneous. If using the Speed-Matic Gauge, simply feed stock through the machine. Production speed is limited only by the rate at which stock can be fed.\*\*

\*When "parting" material of a fairly large diameter, the material should be positioned against the Trigger so that approximately 1/2 of it is best to position the entire material against the face.

\*\*When using Rod Parter on production runs, operator must apply continuous pressure on stock so that it will advance as soon as gauge returns to start position. If operator has trouble feeding stock through Rod Parter, it usually can be remedied by one of the following suggestions:

- A. See that cutting heads are properly aligned. Check section "Aligning Cutting Heads" on page 7.
- B. Check types of stock used. Be sure operator is not trying to feed hot rolled bar stock through cutting heads with holes designed for "parting" cold rolled bar stock.
- C. Make sure pressure is applied to bar stock at all times
- D. Check material in relation to gauge to see that it is positioned properly.
- E. Check brake adjustment. See section "Trouble Shooting in Clutch Assembly" on page 7.

**Installing Speed-Matic Gauge**

When a Speed-Matic Gauge is ordered with a Power Parter, it is delivered completely wired and assembled. To set-up Speed-Matic unit, follow the same procedure as suggested for setting up Material Length Gauge.

## REMOVING & SHARPENING CUTTING HEADS

### Removing and Sharpening Cutting Heads

The Cutting Heads on the hand and power Di-Acro Rod Parter are designed so that their positions can be reversed to give extra cutting service before sharpening.

To do this, turn Cutting Heads around so that the outside sections are back to back.

### To Remove Cutting Heads

1. Remove Center Pivot Bolt, Link Bolt and disengage Upper Casting.
2. Remove socket head screws in both the Upper and Base Casting, and tap out Cutting Heads.

**To Sharpen Cutting Heads**, grind them approximately .002" to .005" on a surface grinder or return them to the factory for this service.

### Aligning Cutting Heads

The stroke adjustment on the Power Rod Parter has been preset at the factory for exact line-up of Cutting Heads. If, after removing Cutting Heads, additional line-up is needed: loosen nuts on top and bottom of Connecting Rod and readjust stroke for proper alignment.

Cutting heads may also need re-alignment after continuous "parting" of larger bar stock. \* For exact line-up follow the same procedure as above.

\*Also see section on Brake Adjustment if cutting heads will not line up.

### Lubrication

To insure smooth, effortless operation, lubricate the power operated Rod Parter periodically in the following places.

#### Power Model

Grease fitting on Center Stud Bolt.  
Connecting Rod Link.

The driving mechanism on the Power Model turns on bronze bearings and should be lubricated periodically. Provision is made for lubrication in the following places with 30wt machine oil.

Connecting Rod Bearing

Crank Shaft Bearing Block, right and left.

Sleeve Bearings in Motor.

Lubricate Clutch Release Lever before each production run to insure instantaneous response.

### Trouble Shooting in Clutch Assembly

#### Brake Adjustment

The Brake on the Crankshaft has been preset to stop "on center" at the end of each operating cycle. After continuous use, the Crankshaft may tend to go over center causing the machine to repeat its operating cycle or stop short of it thus producing a clicking sound.\* Either way, if the brake does not stop the crankshaft "on center", cutting heads will not line-up.

Correct adjustment of the Brake can be made by either tightening or loosening Brake Adjusting bolts so that the Crankshaft stops "on center". If the Brake is set too tight, the Crankshaft will stop before completing its cycle, failing to fully disengage Clutch Pin from Flywheel Pins. Not only will this prevent exact lineup of Cutting Heads but will also cause the Clutch Pin to strike the Flywheel Pins and over a period of time cause distortion. On the other hand, if Brake Band is too loose, cutting heads will again fail to line-up and "parting" cycle repeat itself and possibly cause work damage.

\***Note.** A clicking sound is also produced by incorrect hook-up of wiring. If in doubt about clicking sound, carefully re-read instructions pertaining to correct wiring procedure.

#### Binding Clutch Pin

When the Clutch Pin does not fully engage or disengage after each operating cycle, a continuous clicking sound will be heard as it strikes the edge of the Flywheel Pins. A binding Clutch Pin may be caused by any of the following reasons. It should be remedied before it causes additional damage.

##### A. Check Spring Tension

A special spring is located inside the Clutch Pin forces the Clutch Pin against the Flywheel Pins when the Trip Mechanism is released. If this spring becomes weakened, it allows the Clutch Pin to but partially engage. Result – possible distortion and binding.

##### B. Check Ends of Clutch Pin

If the Clutch Pin has been defaced or shows signs of excessive wear, it's a good indication that it has not been fully engaging or disengaging. Check spring tension and Brake Adjustment before replacing this Clutch Pin to eliminate any further clicking and damage to the Clutch Assembly.

##### C. Adjusting Speed-Matic Gauge

If the parted stock doesn't eject from the cutting heads, see paragraph seven under Installing Material Length Gauge on page six.

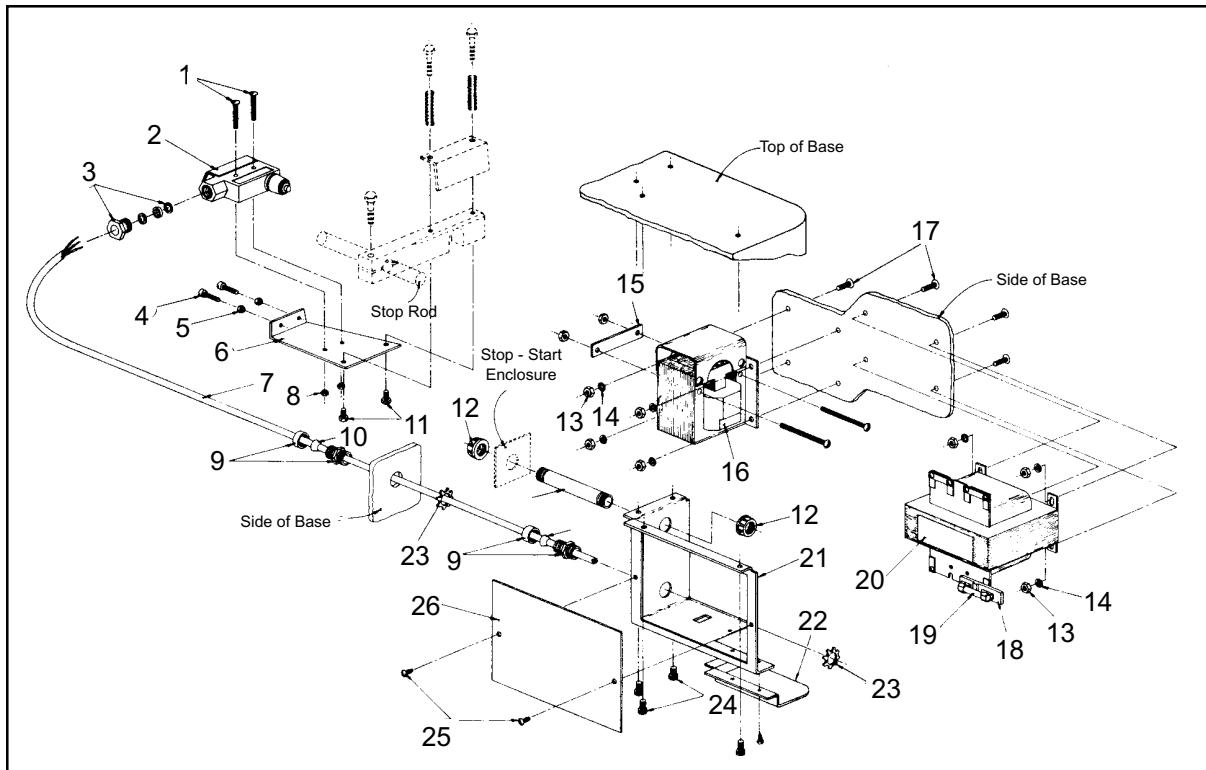

Item No.	Part No.	Description	Qty Used
1	3305001	Seal	1
2	3305002	Limit Switch	1
3	22AXX06C1102	Round Head Machine Screw	2
4	22DXX08C0304	Fillister Head Machine Screw	2
5	31XCC08C	Jam Nut	2
6	085-1410026	Speedmatic Mount	1
7	3316903	Flex Cord	5
8	31XXX06C	Jam Nut	2
9	3315111	Str Gord Grip	2
10	3315116	Bushing	2
11	21A0104C0304	Hex Hd Cap Scr	2
12	3315073	Bushing Ins	2
13	31X0104C	Jam Nut	8
14	4902005	Lock Washer	8
15	085-1410028	Coil Strap	1
16	3306001	Solenoid	1
17	22D0104C0508	Truss Head Machine Screw	8
18	3308001	Fuse Holder	1
19	3318030	Fuse Mdl	1
20	3311011	Transformer	1
	3311035	Transformer	1
21	085-3307001	Enclosure	1
22	085-3307003	Cover	1
23	331-5205	Lock Nut	2
24	20A0104C0308	Socket Head Cap Screw	4
25	26DXX10C0104	Truss Head Thd Cut Screw	5
26	085-3307002	Cover	1
27	3705218	Nipple	1

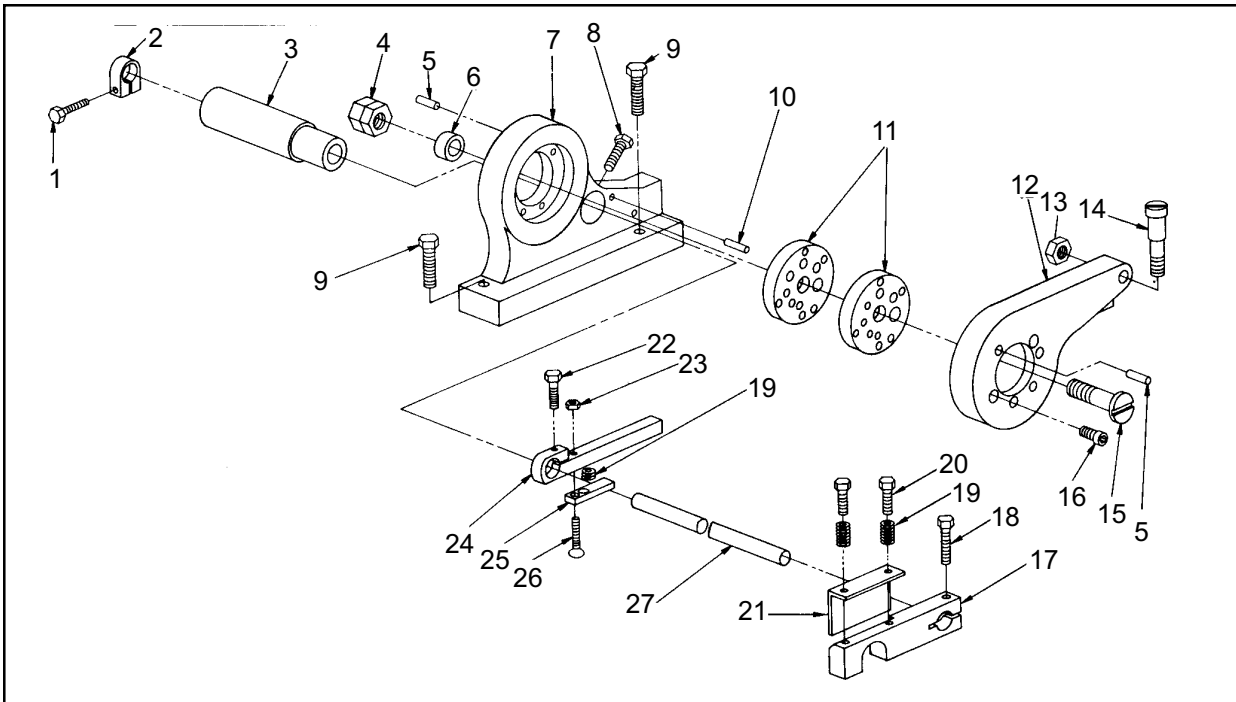

Item No.	Part No.	Description	Qty Used
1	21A0104C03004	Hex Head Cap Screw	1
2	086-1410006	Stop Rod Collar	1
3	086-1410701	Stop Mount Assy	1
4	4704102	M-F Lock Nut	1
5	1203141	Dowel Pin	8
6	080-1108003	Spacer	1
7	085-1101001	Base Casting	1
8	21A0516C1000	Hex Head Cap Screw	1
9	21A0102C1304	Hex Head Cap Screw	2
10	1203178	Dowel Pin	2
11	080-0000602	Set Std Dies	1
12	080-1102002	Upper Casting	1
13	31X0102C	Jam Nut	1
14	080-4701007	Long Stud Bolt	1
15	080-4701009	Center Stud Bolt	1
16	20A05169C0304	Socket Head Cap Screw	4
17	085-1410025	Speedmatic Stop Arm	1
18	21A0516C1104	Hex Head Cap Screw	1
19	151-5102068	Compression Spring	2
20	21A0104C1104	Hex Head Cap Screw	2
21	086-1410007	Stop Rod Trigger	1
22	21A0104C1000	Hex Head Cap Screw	1
23	31X014C	Jam Nut	1
24	086-1410008	Stop Rod Trip Clamp	1
25	086-1410009	Stop Rod Trip Ret	1
26	086-4701004	Stop Rod Bolt	1
27	085-1410011	Stop Rod	1
28	310-5102068	Spring	1



**PARTS LIST (Lower Assembly)**

Item No.	Part No.	Description	Qty Used
1	21A0308C1104	Hex Head Cap Screw	3
2	1203145	Dowel Pin	2
3	086-1110011	Material Support Bar R	1
4	086-1413021	Stripper Plate	1
5	4901102	Flat Washer	4
6	21A0104C1104	Hex Head Cap Screw	2
7	21A0516C1000	Hex Head Cap Screw	2
8	086-1413022	Stripper Guide	1
9	086-1413023	Stripper Arm	1
10	21A0516C0102	Hex Head Cap Screw	1
11	151-5102068	Compression Spring	2
12	086-1413020	Stripper Support Assy	1
13	086-1110015	Material Support Clamp Assy	2
14	21A0516C0304	Hex Head Cap Screw	2
15	085-1109049	Cabinet	1
16	085-1110065	Crankshaft Support Assy	1
17	032-6503018	Arrow Plate	1
18	4401001	V-Belt	1
19	21A0516C3000	Hex Head Cap Screw	4
20	035-1110079	Motor Mount	2
21	035-1110080	Motor Mount Clamp	2
22	31X0104C	Jam Nut	3
23	4901106	Flat Washer	6
24	31X0308C	Jam Nut	2
25	035-1301100	Pedal Bkt Widmt	1
26	22D0104C0508	Truss Head Machine Screw	2
27	4902004	Lock Washer	2
28	31X0516C	Jam Nut	2
29	035-1308003	Foot Pedal	1
30	21A0516C1104	Hex Head Cap Screw	2
31	250-1301064	Foot Pedal Link Block	1
32	035-1325033	Pedal Arm	1
33	1203135	Spring Pin	1
34	510211	Spring	1
35	21A0516C0508	Hex Head Cap Screw	4
36	3301112	Motor	1
37	035-6503001	Warning Plate	1
38	085-6501109	Name Plate	1
39	3304043	Manual Starter	1
40	086-1110010	Material Support Leg	1
41	21A0308C3304	Hex Head Cap Screw	1
42	4901159	Flat Washer	1
43	3104108	Oilite Bearing	2
44	086-1110018	Roller	1
45	1203147	Dowell Pin	1
46	21Av0104C0304	Hex Head Cap Screw	1
47	036-1110017	Roller Support	1
48	086-1110012	Material Stop Bar L	1

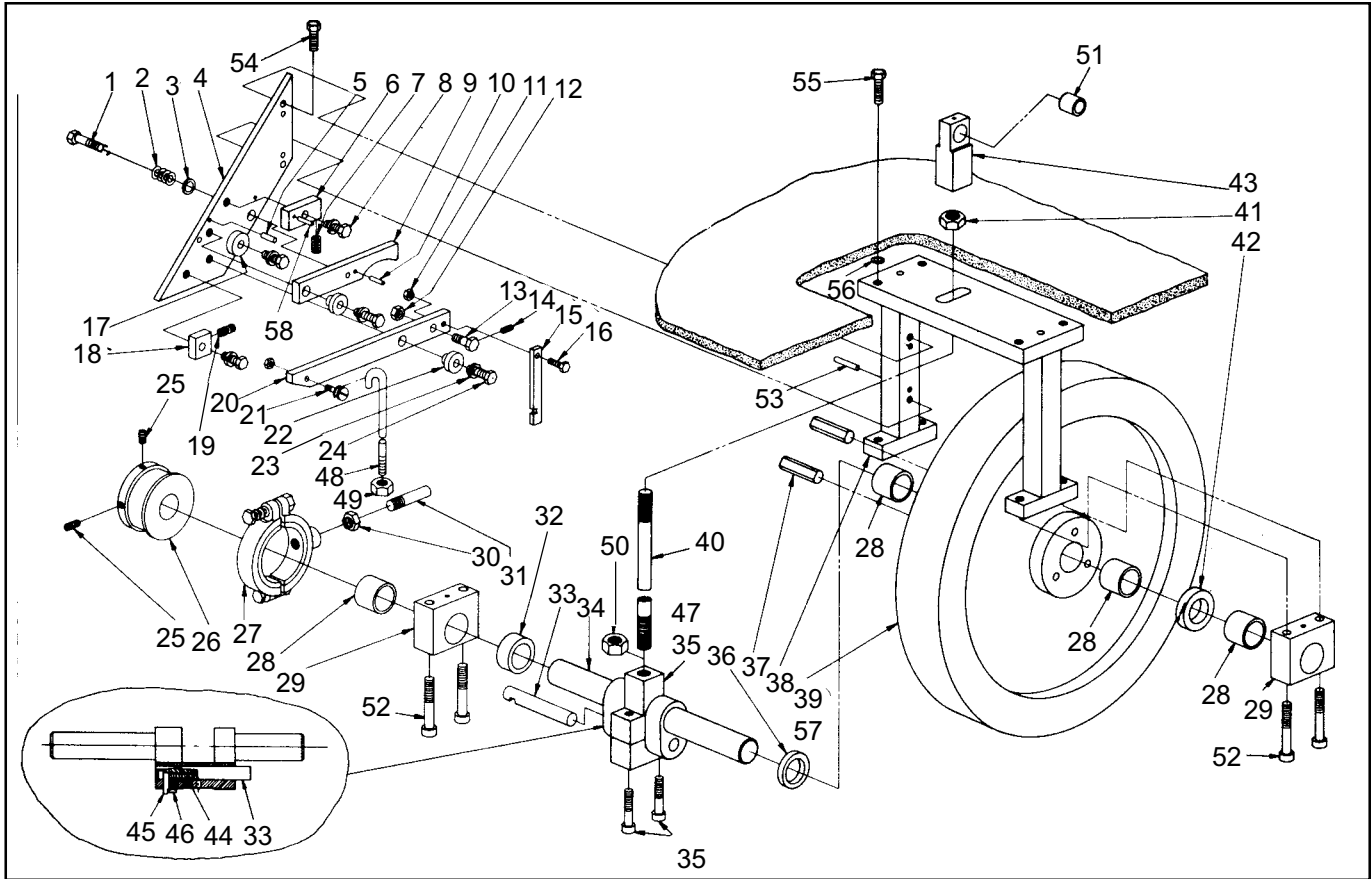

**PARTS LIST (Drive Group)**

<b>Item No.</b>	<b>Part No.</b>	<b>Description</b>	<b>Qty Used</b>
1	25X0516C1104	Shoulder Screw	1
2	5102101	Spring	1
3	4901160	Flat Washer	1
4	035-1110090	Trip Mount	1
5	1203192	Dowel Pin	1
6	035-1301091	Spring Container	1
7	5102102	Spring	1
8	21A0308C1104	Hex Head Cap Screw	2
9	035-1301096	Clutch Release Lever	1
10	1203105	Dowel Pin	1
11	31X0104C	Jam Nut	2
12	31X0308C	Jam Nut	1
13	035-1301097	Spring Bolt	1
14	120-5102022	Spring	1
15	035-1301094	Safety Link	1
16	21A0104C1000H	Hex Head Cap Screw	1
17	035-1301092	Spacer	1
18	035-1206083	Spring Container	1
19	5102103	Spring	1
20	085-1410027	Trip Lever	1
21	250-1301062	Foot Pedal Pivot Stud	1
22	250-1108069	Link Spacer Sleeve	2
23	4902008	Lock Washer	5
24	21A0308C1000	Hex Head Cap Screw	3
25	23A0516C1000	Socket Set Screw	2
26	270-1207054	Brake Collar	1
27	270-1207710	Brake Shoe Assy	1
28	3104104	Bearing	4
29	035-1110067	Crankshaft Bearing Block	2
30	30X0102F	Full Nut	1
31	056-1207056	Brake Rod	1
32	035-1201069	Crankshaft Trip Spacer	1
33	035-1206089	Clutch Dog	1
34	035-1201060	Crankshaft Assy	1
35	085-1201752	Connectin Rod Assy	1
36	035-1206085	Clutch Spacer	1
37	035-1206084	Drive Pin	3
38	086-1110065	Crankshaft Support Assy	1
39	035-1204086	Flywheel	1
40	085-1201050	Connecting Rod	1
41	31X0508F	Jam Nut	1
42	035-1201087	Flywheel Spacer	1
43	085-1201051	Connecting Rod Link	1
44	035-5102082	Spring	1
45	035-1203066	Clutch Dog Pin	1
46	22FXX06C0104	Binder Head Machine Screw	1
47	035-3106055	Bearing Insert	1
48	035-130109	Foot Pedal Link Rod	1
49	31X0516C	Jam Nut	1
50	31X0508C	Jam Nut	1
51	3104101	Oilite Bearing	1
52	20A0308C3000	Socket Head Cap Screw	4
53	1203178	Dowel Pin	2
54	21A0516C1000	Hex Head Cap Screw	2
55	21A0308C1104	Hex Head Cap Screw	4
56	4901159	Flat Washer	4
57	6901001	Oil Cup	1
58	1203134	Spring Pin	1