

DiAcro[®]

NUMBER 2 POWER OPERATED NOTCHER



DiAcro[®]

METAL FABRICATION EQUIPMENT

579 SCHOMMER DR - STE C

HUDSON, WI 54016

(651) 342-1756 (P)

DISCLAIMER

DI-ACRO by supplying this manual is not liable for any indirect, incidental, or consequential damages or injuries sustained or incurred in connection with using the information in any way contained herein.

DI-ACRO accepts no responsibility or liability resulting from attempts to use this information.

DI-ACRO does not vouch for or warrant the accuracy, completeness or usefulness of any information contained herein.

WIRING

Cost includes wiring for either of the following standard electrical systems.

110 or 220 volt single phase

220 or 440 volt three phase

Hook up lead-in wires and switch Motor on to check the direction of Flywheel. It should operate in a counter-clockwise direction as indicated by the **arrow**.

If the lead-in wires have been incorrectly hooked up, Tripping Mechanism will fail to operate. To remedy this, simply reverse any two lead-in wires.

CAUTION**TO PREVENT SERIOUS BODILY INJURY
AND DAMAGE TO THE MACHINE****BOLT THE MACHINE TO THE STAND
AND THE STAND TO THE FLOOR****SETUP PROCEDURE****POWER NOTCHER**

Except for wiring, the power operated Di-Acro Notcher is delivered ready for operation. To set up, simply hook up wiring, adjust Gauges for the proper size notch and machine is ready for production.

Smooth, even notches can be cut in all types of ductile material with the Di-Acro Notcher. It eliminates the high cost of special dies required for each different notching operation and does away with time wasted in punch press setup—you simply adjust the Material Gauge and you're ready for production.

Both power and hand operated models of this precision machine are available. They are equally useful in the experimental shop or on the production line.

Adjustable gauges are used to locate a notch of any dimension at the corner of a sheet of material or at any position along the edge of the sheet. Notches greater or less than 90 degrees can be obtained in two operations and many straight shearing operations can also be performed. The hardened and ground Triangular Ram used in the Di-Acro Notcher will provide years of continuous, trouble-free performance and assure a clean cut free from rough edges or burr.

SETUP

A. Change size of tab (set at factory for 1/2" tab)

1. Loosen bolts (A) holding lower blade to blade carrier (do not remove).
2. Slide blades forward or back, holding them against shoulder machined in blade carrier to obtain desired tab.
3. Tighten bolts (A).
4. Loosen bolts (B).
5. Lower ram until upper blades pass by lower blades (it may be necessary to slide one upper blade back).
6. Slide blade (C) forward into notch in lower blade. Tighten bolts.
7. Slide blade (D) forward until it contacts blade (C). Tighten bolts.
(Note: A slight opening at (H) is normal to insure contact at cutting edge.)

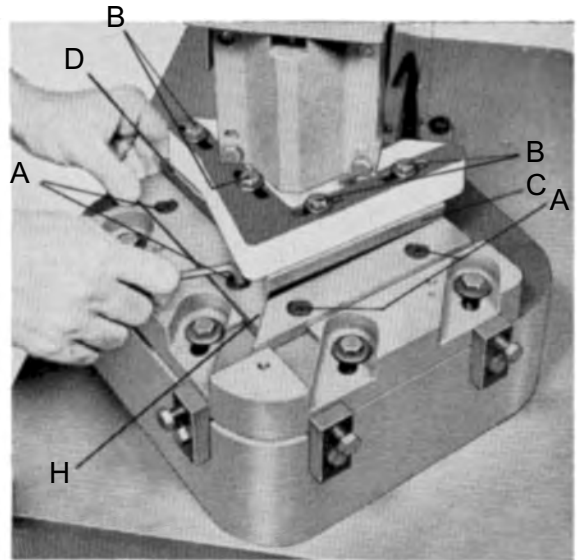

B. Setting size of notch

1. Loosen screws (G) and set to required notch depth, reading scale along edge (E).
Note: Scale is set to read from the edge of the notch so tab size must be subtracted to obtain a corner notch of equal depth.
2. To notch along the side of a sheet, remove gauges and turn them upside down. Screws will fit in outside slot when gauges are set parallel to each other.

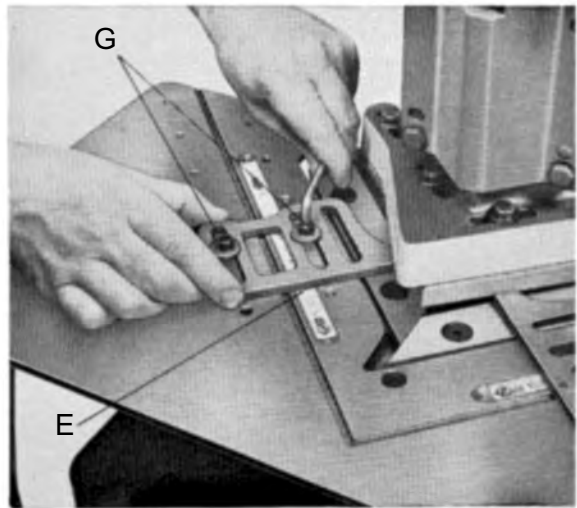

C. Shearing long strips full width

1. Remove lower left blade and adjust right blade to maximum tab size.

D. Setting depth of stroke

1. With power off, step on foot pedal and turn flywheel by hand until ram is at bottom of stroke.
2. Remove pin (N) and loosen lock nut (O)
3. Lower ram by hand until upper blade is 1/16" below edge of lower blade.
4. Adjust connecting rod link on shaft until pin (N) will re-enter hole. Re-tighten lock nut (O).

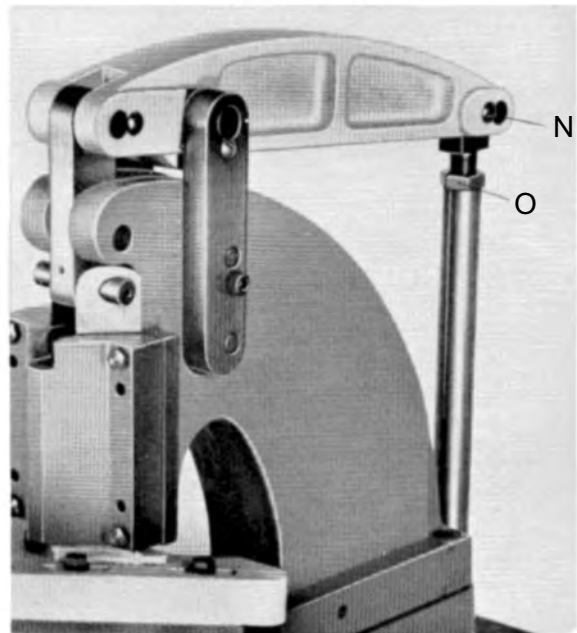

CAUTION: Be sure ram will clear material gauges before operating machine.

MAINTENANCE

A. Sharpening blades

1. Blades are dual edged. A new cutting edge is obtained by changing right blade to left side and visa versa.
2. If only a slight amount of sharpening is required, grind wide edge only, as this will eliminate necessity of resetting clearance.
3. When grinding ends be sure to maintain angle presently on blade.
4. Reset scale to zero, lining up zero on scale with straight edge along blade cutting edge

B. Adjusting blade clearance

1. Remove table.
2. Loosen blade mounting bolts A and B.
3. Loosen blade carrier bolts J.
4. Adjust lower blades to required tab (per instructions, A-1, 2, 3, under SETUP).
5. Set upper blades for no tab or a tab smaller than set in lower blades.
6. Back off screws K and pull blade carrier away from top blade.
7. Move ram to bottom of stroke.
8. Turn in screws K by hand pushing blade in until it contacts upper blade. Placing a shim or piece of paper between blades will provide clearance to prevent rubbing of blades. Too much clearance will cause burr on workpiece. Excessive rubbing of blade will reduce blade life.
9. Tighten bolts J.
10. Set upper blade to tab notch in lower blade and tighten.

C. Adjusting ram clearance

1. Remove ram cap M and remove a shim from both sides. Color of shim indicates the thickness: Purple .0015; Red .002; Green .003; Blue .005.
2. Replace cap.

LUBRICATION

1. Lower unit of Notcher is equipped with oilite bronz bearing requiring occasional lubrication at points indicated in photos. (Rocker arm not shown)
2. Upper unit should be oiled daily at points indicated
3. Clutch linkage - oil occasionally.

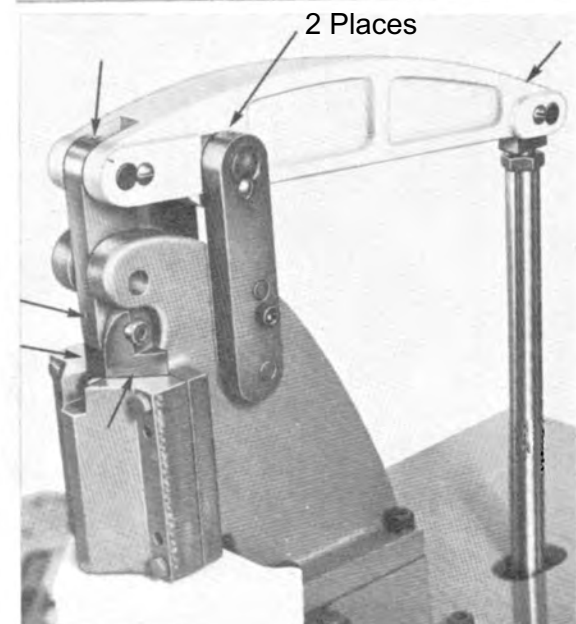
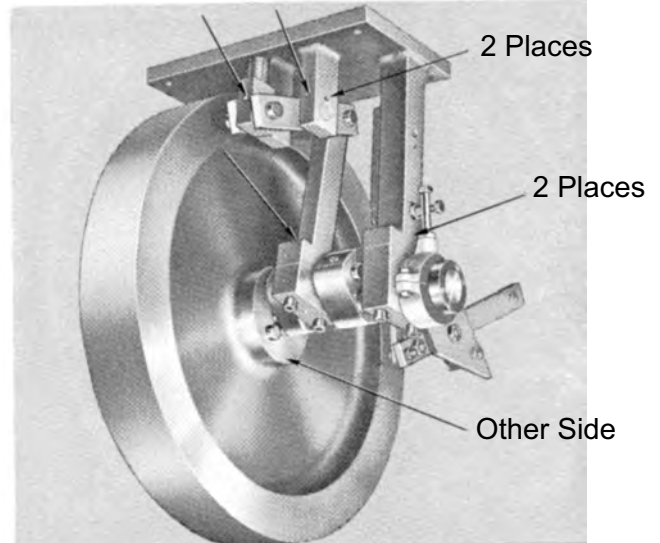
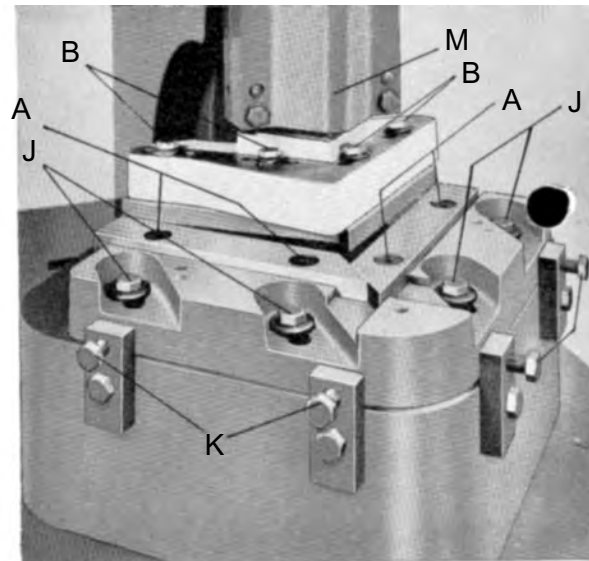

TROUBLE SHOOTING

Problem: Double tripping, or not stopping at end of single cycle.

Cause: Brake too loose, causing dog to coast on by release lever.

Remedy: Tighten brake adjustment.

Cause: Brake too tight, or ram binding, causing release lever to slip by instead of pulling clutch dog.

Remedy: Loosen brake, or remove pin N and check for binding in ram. If binding remove cap and remove burrs and polish ram until it is operating freely.

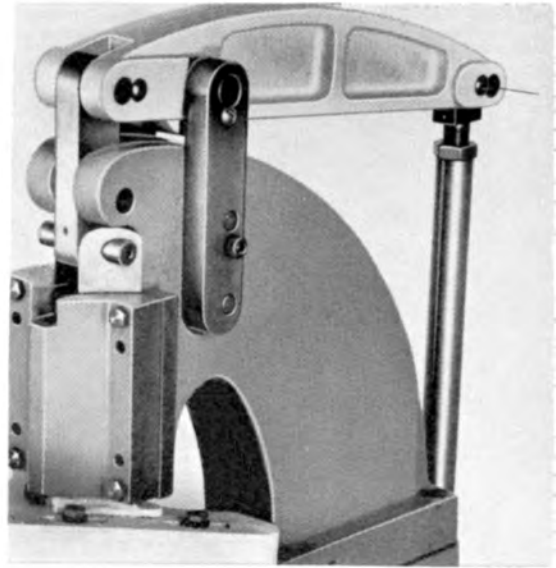

Problem: Machine will not operate when pedal is depressed.

Cause: Clutch dog binding, or broken spring.

Remedy: Rotate flywheel by hand to bottom of stroke: Remove brake collar and brake assembly. Remove screw R and pin S. Pull out clutch dog. Remove burrs particles. Replace spring is weak or broken. (To replace clutch dog remove bolts T and slide flywheel in direction indicated by arrow. Insert clutch dog and pin S. Tighten screw R. Slide flywheel back into place and re-tighten bolts T.)

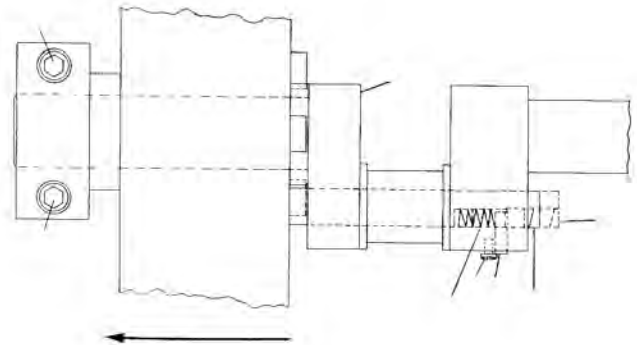

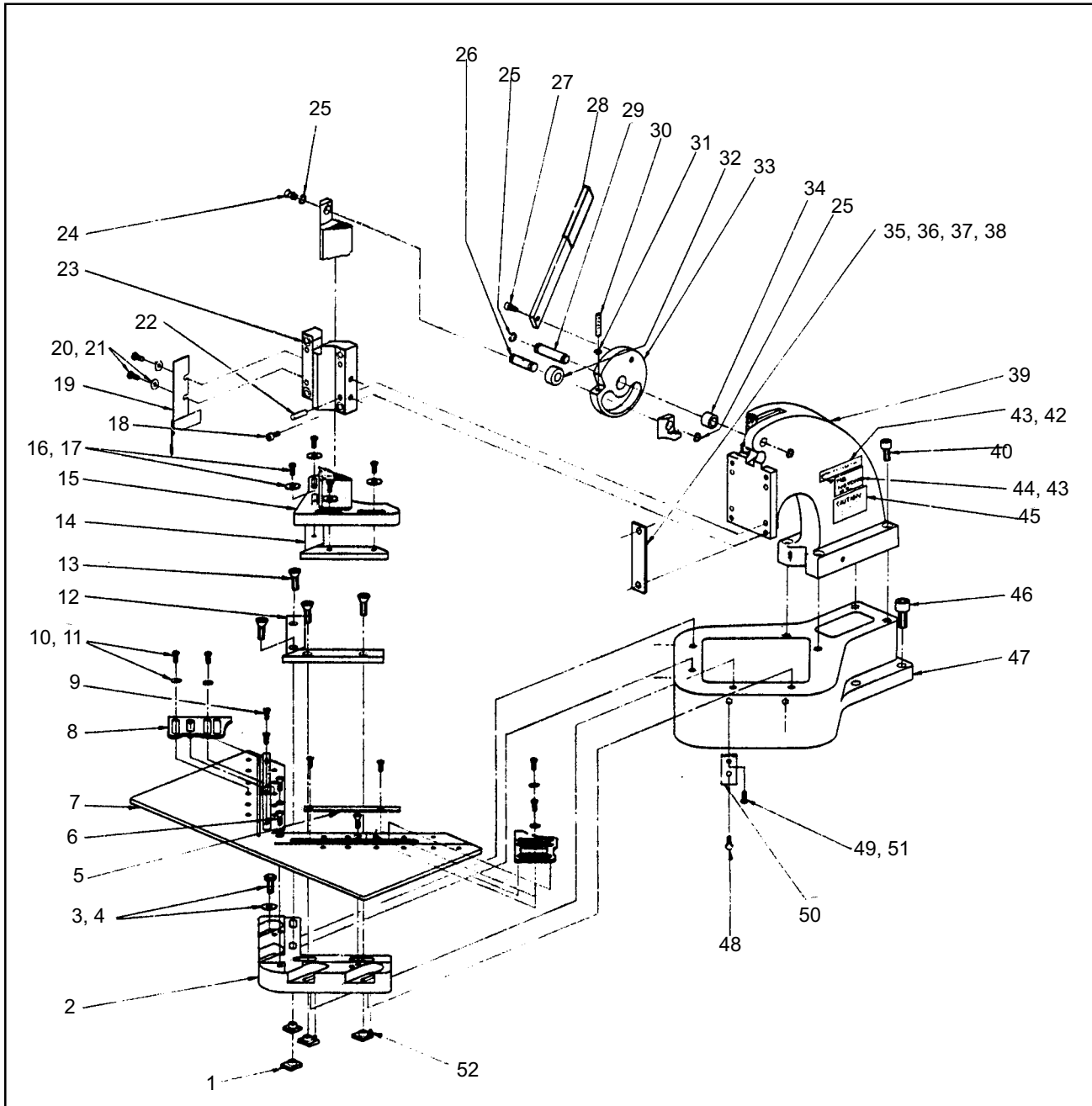

ITEM	DESCRIPTION	PART NUMBER	QTY
1	T-NUT	8905350-000	4
2	BLADE CARRIER	8031110-101	1
3	HEX HEAD CAP SCREW	21A0308C1102	4
4	FLAT WASHER	61X0308C1332	4
5	RULE	8031160-101	2
6	FLAT HEAD SOCKET CAP SCREW	20C0104F0102	3
7	TABLE	8000110-501	1
8	PROTRACTOR GAUGE	8031140-571	2
9	BINDER MACHINE SCREW	22FXX060108	4
10	FILLISTER HEAD MACH SCREW	20A0104F0508	4
11	FLAT HEAD WASHER	51X0104	4
12	LOWER BLADE	8031120-901	2
13	FLAT HEAD SOCKET CAP SCREW	20C0516C2000	4
14	UPPER BLADE	8031120-900	2
15	RAM ASSEMBLY	8031121-300	1
16	HEX HEAD CAP SCREW	21A0516C1102	4
17	FLAT WASHER	61X0516	4
18	SOCKET HEAD CAP SCREW	20A0516C1102	4
19	GUARD ASSEMBLY	8031110-609	1
20	HEX HEAD CAP SCREW	21A0516C0102	4
21	FLAT WASHER	61X0308-0104	4
22	SPRING PIN	0012220-000	4
23	CAP	8040110-800	1
24	DRIVE FITTING	8690100-200	1
25	RETAINER RING	8470510-100	4
26	CAM ROLLER PIN	8060120-300	1
27	BUTTON HEAD SOCKET CAP SCREW	20B0516C0508	1
28	LONG HANDLE ARM	8030120-800	1
29	CAM PIN	8030120-302	1
30	SQUARE HEAD SET SCREW	23C0516C2000	1
31	JAM NUT	31X0516C	1
32	ROLLER	8156111-300	1
33	CAM	8030120-200	1
34	BEARING	8310410-100	1
35	SHIM	8030570-101	2
36	SHIM	8930570-101	2
37	SHIM	8940570-101	1
38	SHIM	8030570-102	1
39	UPPER CASTING	8040110-200	1
40	SOCKET HEAD CAP SCREW	20A0102C1304	4
41	SOCKET HEAD CAP SCREW	20A0516C1102	1
42	INSTRUCTION PLATE	8030650-310	1
43	DRIVE SCREW ROUND HEAD	29AXXX0X0108C	4
44	NAME PLATE	031-6501110	1
45	CAUTION PLATE	8030650-300	1
46	HEX HEAD CAP SCREW	21A0102C1304	4
47	BASE	8031110-100	1
48	HEX HEAD CAP SCREW	21A0308C1000	4
49	JAM NUT	31X0102C	4
50	BACKUP PLATE	031-1105011	4
51	HEX HEAD CAP SCREW	21A0308C1104	4
52	SPRING PIN	8120313-600	4

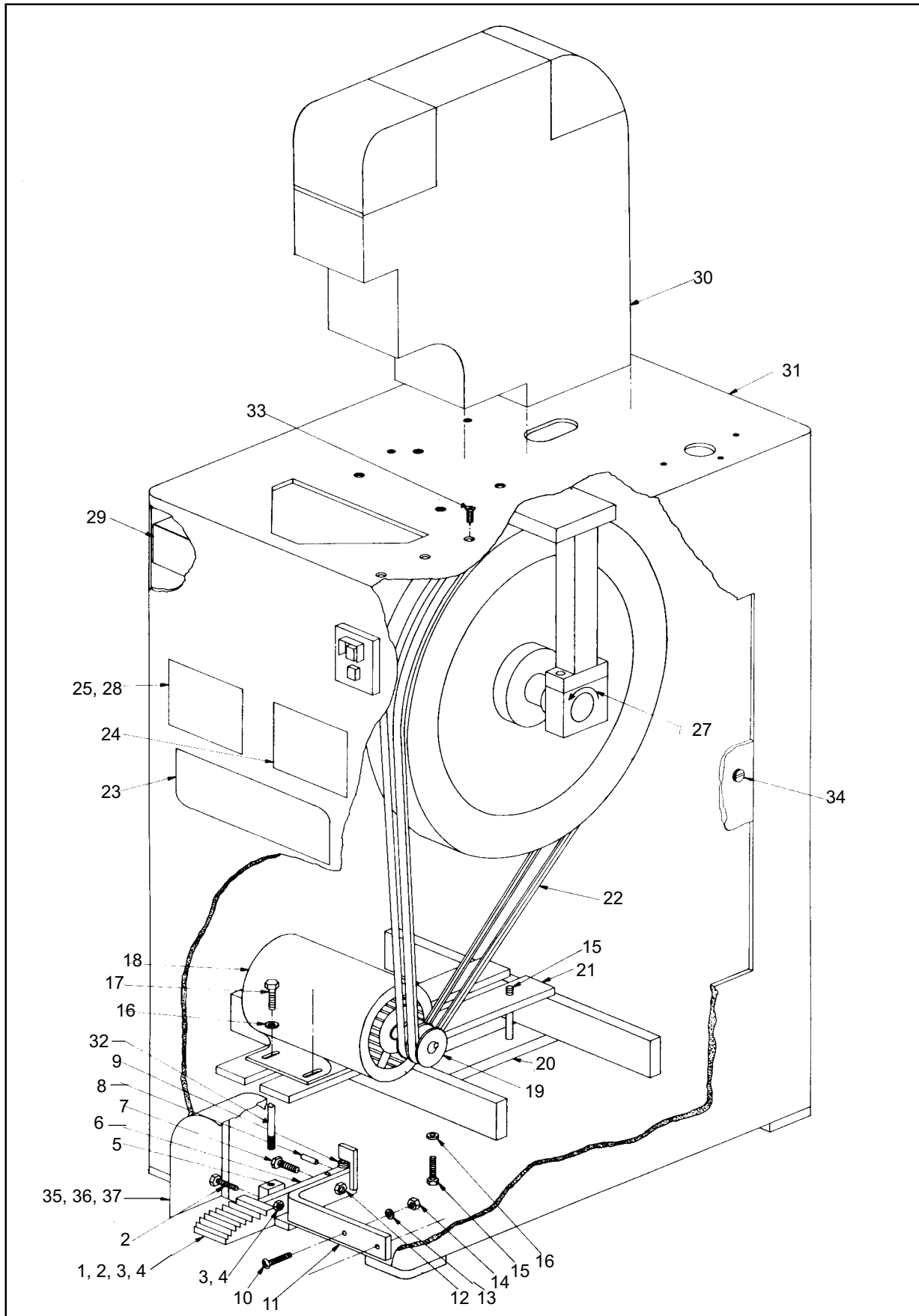

Item No.	Part No.	Description	Qty
1	035-1308003	Foot Pedal	1
2	21A0516C1104	Hex Head Cap Screw	1
3	62X0516M	Lock Washer	1
4	31X0516C	Jam Nut	1
5	250-1301064	Foot Pedal Link Block	1
6	035-1325033	Pedal Arm	1
7	21A0308C1104	Hex Head Cap Screw	1
8	1203135	Spring Pin	1
9	5102103	Spring	1
10	22D0104C0508	Truss Head Mach Screw	2
11	035-1301100	Pedal Bkt Wldmt	1
12	31X0308C	Jam Nut	1
13	61X0104	Flat Washer	2
14	31X0104C	Jam Nut	2
15	21A0516C3000	Hex Head Cap Screw	4
16	4901106	Flat Washer	4
17	21A0516C0508	Hex Head Cap Screw	4
19	1205089	Sheave	1
20	035-1110080	Motor Mount Clamp	2
21	035-1110079	Motor Mount	2
22	4401001	V-Belt	1
23	068-6502001	Name Plate	1
24	035-6503001	Warning Plate	1
26	032-6501113	Name Plate	1
27	032-6503018	Arrow Plate	1
28	29AXX0X0108C	Drive Screw	10
29	035-1109701	Chute Assy	1
30	032-1106003	Guard	1
31	032-1109001	Cabinet	1
32	032-1301056	Foot Pedal Link Rod	1
33	22C0104C0508	Flat Head Mach Screw	3
34	4701147	Panel Screw	2
35	6999922	Rubber Extension	1
36	035-1106022	Foot Pedal Guard	1
37	20AXX10C0308	Socket Head Cap Screw	4

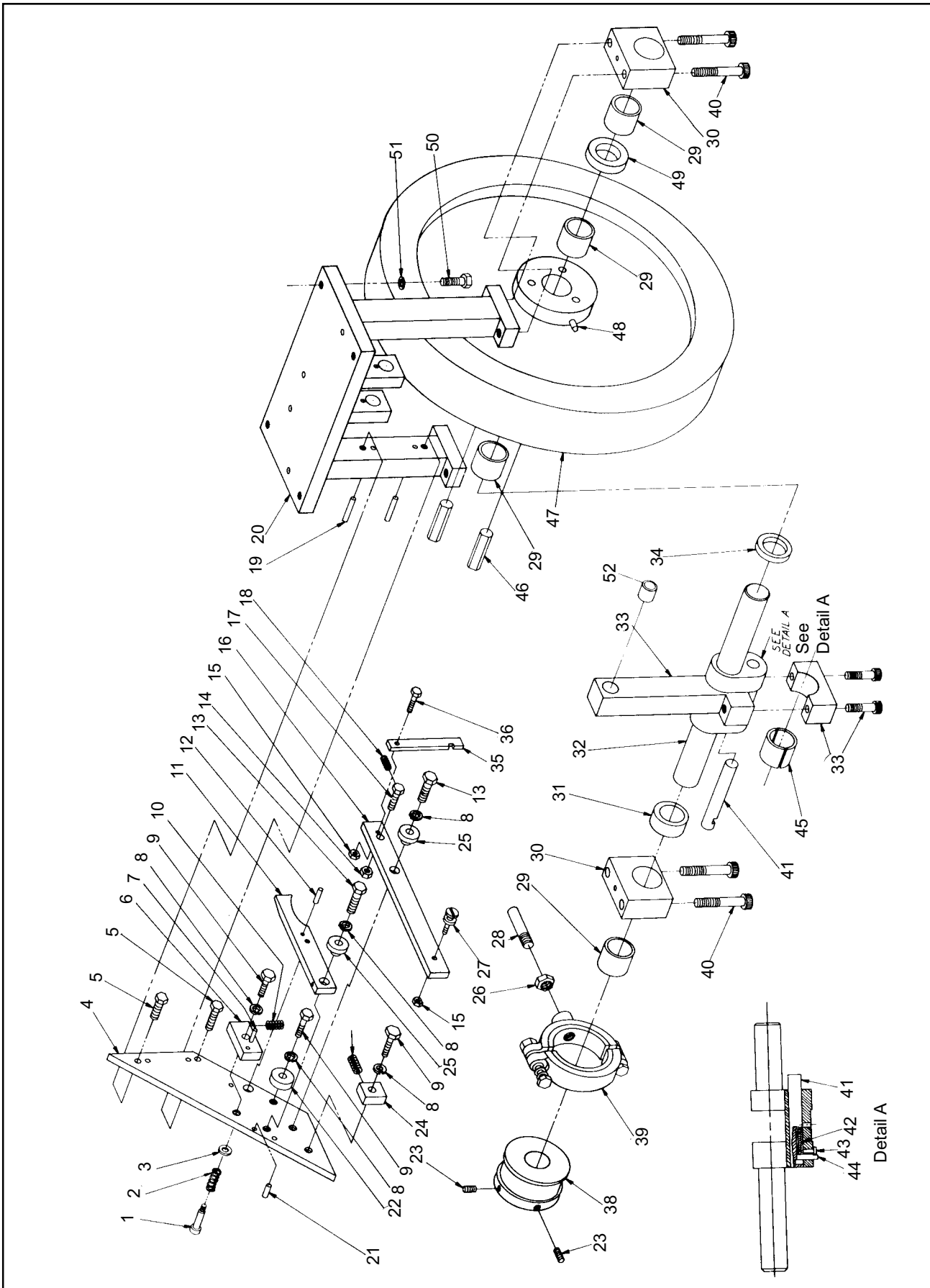

Item No.	Part No.	Description	Qty Used
1	25X0516C1104	Shoulder Screw	1
2	5102101	Spring	1
3	61X0104	Flat Washer	1
4	035-1110090	Trip Mount	1
5	21A0516C1000	Hex Head Cap Screw	2
6	035-1301091	Spring Container	1
7	1203134	Spring Pin	1
8	62X0508	Lock Washer	5
9	21A0308C1000	Hex Head Cap Screw	3
0	5102102	Spring	1
11	035-1301096	Clutch Release Lever	1
12	1203105	Dowel Pin	1
13	21A0308C1104	Hex Head Cap Screw	2
14	31X0308C	Jam Nut	1
15	31X0104C	Jam Nut	2
16	035-1301095	Trip Lever	1
17	035-1301097	Spring Bolt	1
18	120-5102022	Spring	1
19	1203178	Dowel Pin	2
20	035-1110065	Crankshaft Support	1
21	1203192	Dowel Pin	1
22	035-1301092	Spacer	1
2	23A0516C1000	Socket Set Screw	2
24	035-1206083	Spring Container	1
25	250-1108069	Link Spacer Sleeve	2
26	30X0102F	Hex Nut	1
27	250-1301062	Foot Pedal Pivot Stud	1
28	056-1207056	Brake Rod	1
29	3104104	Bearing	4
30	035-1110067	Crankshaft Bearing Block	2
31	035-1201069	Crankshaft Trip Spacer	1
32	035-1201060	Crankshaft	1
33	035-1201702	Connecting Arm Assy	1
34	035-1206085	Clutch Spring	1
35	035-1301094	Safety Link	1
36	21A0104C1000H	Hex Head Cap Screw	1
37	510211	Spring	1
38	270-1207054	Brake Collar	1
39	270-1207710	Brake Show Assy	1
40	20A0308C3000	Socket Head Cap Screw	4
41	035-1206089	Clutch Dog	1
42	035-5102082	Spring	1
43	22F0X06C0104	Binder Head Mach Screw	1
44	035-1203066	Clutch Dog Pin	1
45	035-3106055	Bearing Insert	1
46	035-1206084	Drive Pin	3
47	035-1204086	Flywheel	1
48	411001	Oil Hole Cover	1
49	035-1201087	Flywheel Spacer	1
50	21A0308C1104	Hex Head Cap Screw	4
51	4901159	Flat Washer	4
52	3104101	Bearing	1

BRAKE SHOE ASSEMBLY

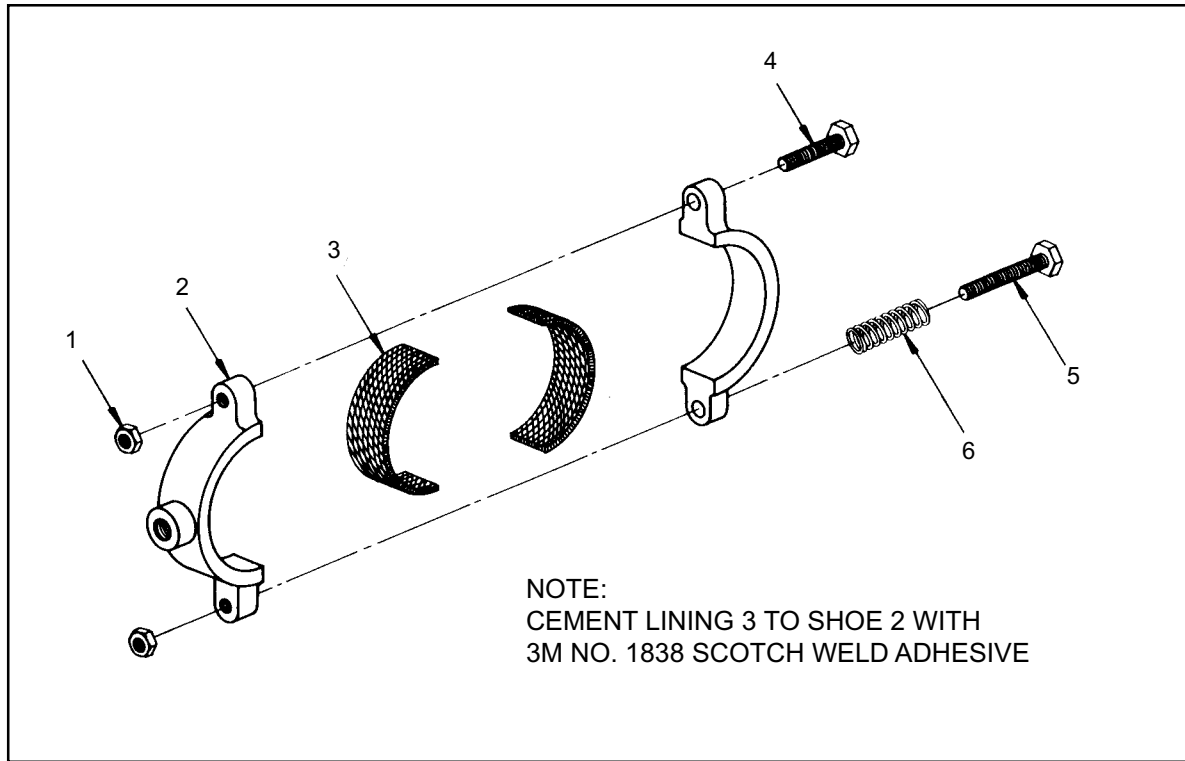

Item No.	Part No.	Description	Qty Used
1	31X0516C	Jam Nut	2
2	270-1207055	Brake Shoe	1
3	270-1207001	Brake Lining	2
4	4701137	Hex Head Cap Screw	1
5	4701112	Hex Head Cap Screw	1
6	512110	Spring	1

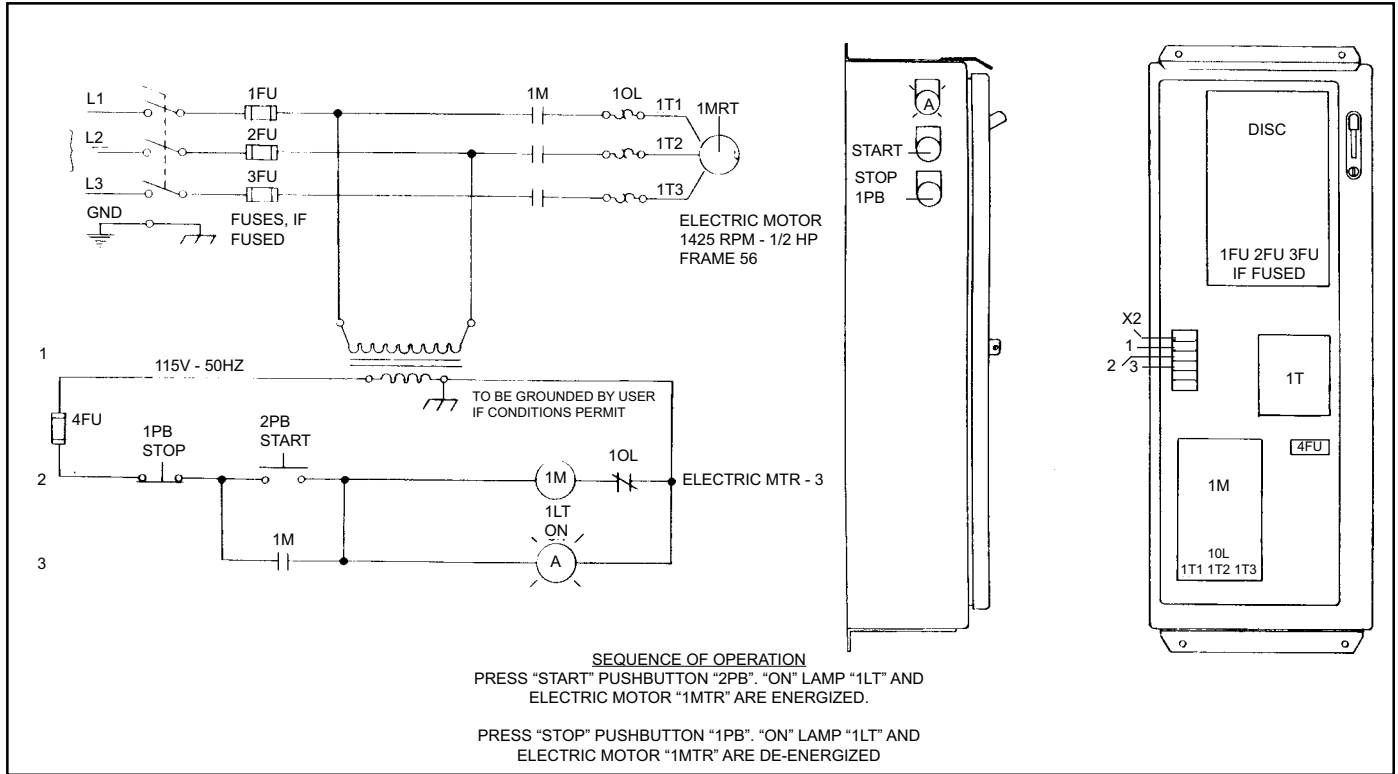

Sym	Part No.	Description	Qty
		Operating Mechanism ~ GE #343L543G3	1
	3308115	Terminal Block ~ Curtis #2PSWTC	3
	065-3308001	Track ~ Curtis SW-96 (5" Length)	1
2PB	3332017	Legend Plate Start Furnas #D11804003	1
2PB	3303088	Contact Block NO ~ Furnas #BJK	1
2PB	3303058	Pushbutton Operator ~ Furnas #BJP2	1
1PB	3332089	Legend Plate - Stop - Furnas #D11804004	1
1PB	3303089	Contact Block NC ~ Furnas BJJ	1
1PB	3303059	Push Button Operator ~ Furnas BJR2	1
1LT	3332015	Legend Plate - On - Furnas D11804013	1
1LT	3303050	Amber Lens ~ Furnas BJ4G	1
1LT	3302013	Pilot Light ~ Furnas BJL1	1
4FU	3318051	Fuse ~ Buss FNM1/2	1
1T	3311043	Transformer Micron BX150MBRTW13-XK	1
10L	3323018	Heater Element ~ Furnas #H-15	3
1M		Starter ~ Furnas 14CF32AA	1
1-3FU	3318014	Fuse Buss #FRS 1-6/10	3
1-3FU		Fuse Clip ~ GE THMC 3100	1
DISC		Disconnect Switch ~ GE THMS 31 Model 2	1
		Enclosure Panel	1

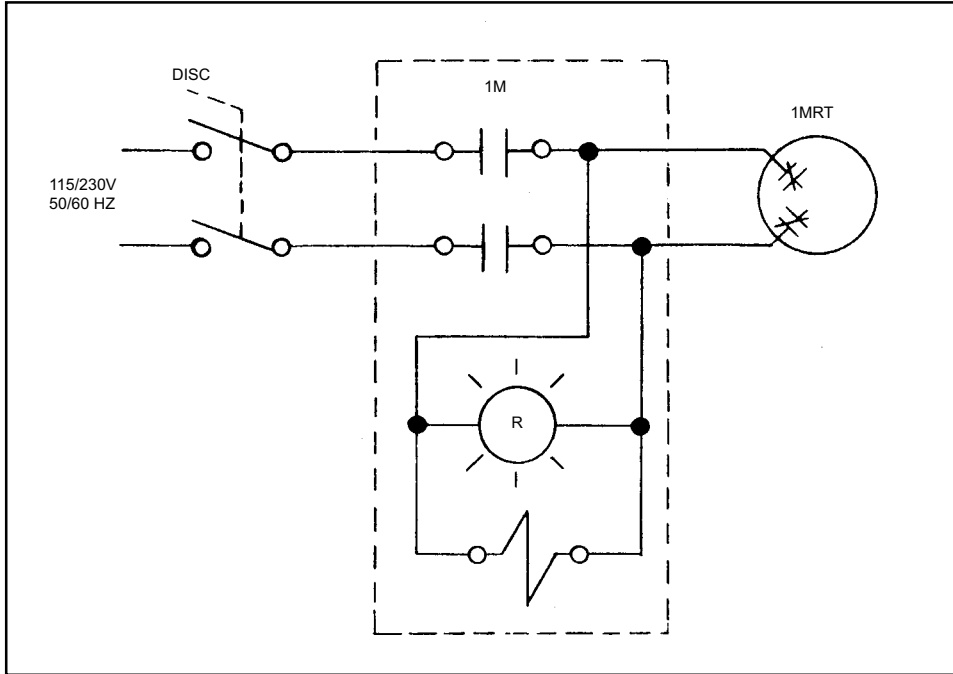

Sym	Part No.	Description	Qty
1MTR	3301020	Motor	1
1M	3304043	Manual Starter Furnas	1
1M	3304042	Manual Starter Furnas	1
DISC	3331013	Disconnect Switch	1