

**DiAcro**<sup>®</sup>  
METAL FABRICATION EQUIPMENT



## #2 PUNCH PRESS OPERATION AND PARTS MANUAL

**DiAcro**<sup>®</sup>

579 Schommer Dr - Ste C

Hudson, WI 54016

Phone: 651.342.1756

**Email: [info@diacro.com](mailto:info@diacro.com)**

## **TABLE OF CONTENTS**

<b>SAFETY INFORMATION</b>	<b>PG. 3</b>
<b>MAINTENANCE</b>	<b>PG. 2</b>
<b>TECHNICAL DATA</b>	<b>PG. 2</b>
<b>SET-UP PROCEDURE &amp; MOUNTING PUNCHES &amp; DIES</b>	<b>PG. 3</b>
<b>PARTS BREAKDOWN</b>	<b>PG. 5</b>
<b>PARTS LISTS</b>	<b>PG. 6-7</b>
<b>DIE HOLDERS/ADAPTERS &amp; PUNCHES</b>	<b>PG. 7-8</b>
<b>STANDARD &amp; COMMON PUNCH &amp; DIE SHAPES</b>	<b>PG. 9-10</b>
<b>STAND</b>	<b>PG. 11</b>
<b>WARRANTY</b>	<b>PG. 12</b>

## **SAFETY INSTRUCTIONS**



Before Punch is set up for operation, mount on work bench or stand\*.

**\*IF PUNCH IS MOUNTED ON ITS OWN STAND, SECURE STAND TO FLOOR**

## **MAINTENANCE**

Put Grease in grease fitting periodically.

## **SPECIFICATIONS**

<b>Model #2 Punch</b>	<b>Inch</b>	<b>Metric</b>
Tonnage	4	3.6
Max. Punch Size	4	101.6
Punch Capacity	1-1/2	38
Throat Depth	12	304.8
Throat Height	3	76
Material Thickness	16 ga. Mild steel	1.5 ga. Mild steel
Stroke of Ram	5/8	15.9
Hole in Ram (dia.)	1	25.4

Shipping Weight	350 lbs.	159 kg
-----------------	----------	--------

## SET-UP & MOUNTING PUNCHES AND DIES

After Punch is bolted to the work bench or stand the following procedure is recommended:

1. Remove both right and left hand Stripper Arm from Ram Cap.
2. Insert Punch in Punch Holder and tighten set screw.
3. Insert Die in Die Holder, tighten set screw and mount on Punch. Do not tighten bolts on Die Holder.
4. Pull handle down until Punch enters Die to line up Punch in center of Die. Tighten bolts in Die Holder.
5. Test alignment of Punch and Die by inserting paper and punching by hand.
6. Select the notch in the Stripper V Plate that will provide the most support around the Punch for stripping, and bolt to stripper Arms and mount on Ram Cap\*. For Punches 5/16" in diameter and smaller a stripper Plate with three holes is provided. Special stripper Plates for round, square, are available by special order.

\*Adjust Stripper Plate vertically as close to material as possible. Leave enough clearance for easy insertion of the material. When Stripper Plate is set too high, material may become distorted.

#1 (See Pg.3)  
Stripper Arms

#2 (See Pg.3)  
Punch Holder

#3 (See Pg.3)  
Die Holder

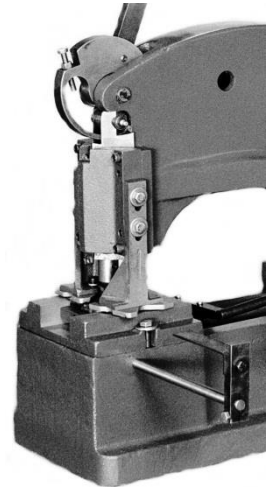
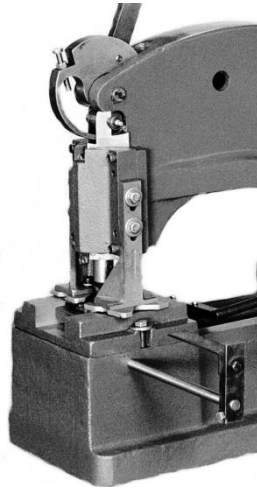
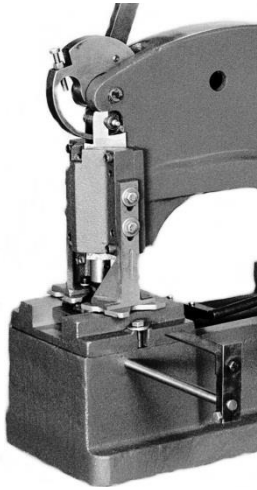

## **#2 HAND PUNCH PRESS PARTS BREAKDOWN**

**8050810-080**

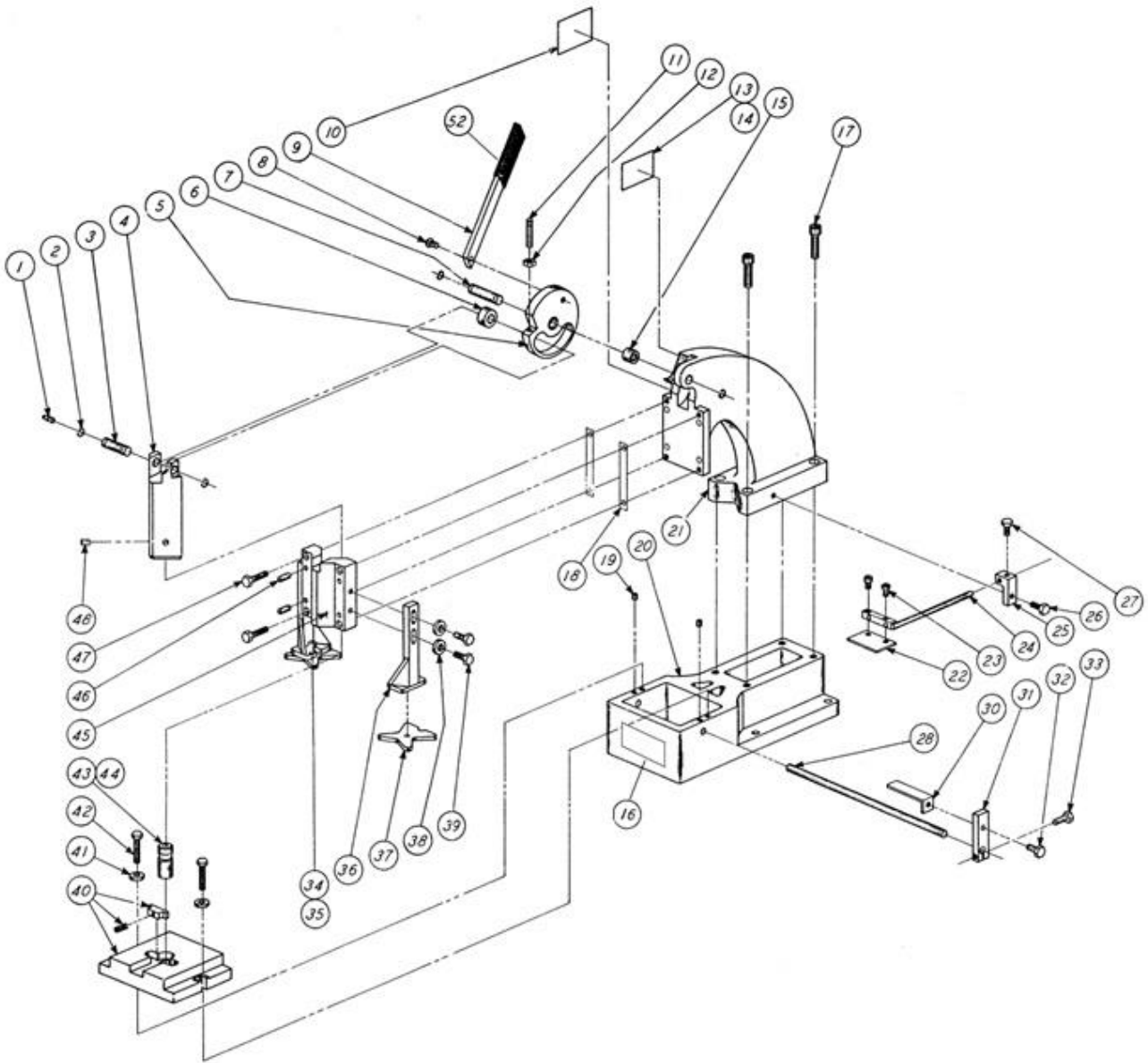

**PARTS LIST  
8050810-080**

ITEM	PART NUMBER	DESCRIPTION	QTY
1	8690100-200	DRIVE FITTING	1
2	8470510-100	RETAINING RING	4
3	8060120-300	CAM ROLLER PIN	1

4	8040121-300	RAM	1
5	8030120-200	CAM	1
6	8156111-300	ROLLER	1
7	8030120-302	CAM PIN	1
8	20B0516C0508	SCREW-BHSCS 5/16-18X5/8	1
9	8030120-800	HANDLE ARM	1
10	030-6503001	CAUTION PLATE	1
11	23C0516C2000	SCREW-SQHSS 5/16-18X2	1
12	31X0516C	NUT-JAM 5/16-18	1
13	8150650-110	NAMEPLATE	1
15	8310410-100	BEARING	1
16	068-6503002	SAFETY SIGN	1
17	20A0102C1304	SCREW-SHCS 1/2-13X1-3/4	6
18	8030570-101	SHIM .0015" PURPLE	VARIES
	8930570-101	SHIM .0020" RED	VARIES
	8940570-101	SHIM .0030" GREEN	VARIES
	8030570-102	SHIM .0050" BLUE	VARIES
19	23A0308C0104	SCREW-SSS 3/8-16X1/4	2
20	8040110-100	BASE	1
21	8050110-200	UPPER CASTING	1
22	8040140-101	BACK MATERIAL GAUGE	1
23	22B0X10C0508	SCREW-FLHMS #10-24X5/8	2
24	8050140-101	BACK MATERIAL ROD WLDMT	1
25	8200140-101	BACK MATERIAL CLAMP	1
26	21A0308C1000	SCREW-HHCS 3/8-16X1	1
27	21A0516C0304	SCREW-HHCS 5/16-18X3/4	1
28	8000140-202	SIDE MATERIAL ROD	1
30	8040140-202	SIDE MATERIAL GAUGE	1
31	8100140-202	SIDE MATERIAL CLAMP	1
32	21A0516C0304	SCREW-HHCS 5/16-18X3/4	1
33	21A0516C1104	SCREW-HHCS 5/16-18X1-1/4	1
34	20A0104C0102	SCREW-SHCS 1/4-20X1/2	2
35	61X0104	WASHER-FLAT 1/4	4
36	8040140-302	STRIPPER ARM	2
37	8100140-302	STRIPPER PLATE	2
38	61X0516	WASHER-FLAT 5/16	4
39	21A0516C1104	SCREW-HHCS 5/16-18X1-1/4	4

**PARTS LIST -CONTINUED  
8050810-080**

ITEM	PART NUMBER	DESCRIPTION	QTY
40	8040150-270	DIE HOLDER C ASSY	1
	8040150-205	DIE SHOE ONLY	1
	8066150-205	CLAMP	1

	22B0X10F0102	FLHM SCREW	1
40A	8040150-375	DIE ADAPTER ASSY "A"	1
40B	8000150-375	DIE ADAPTER ASSY "B"	1
41	61X0308	WASHER-FLAT 3/8	2
42	21A0308C1304	SCREW-HHCS 3/8-16X1-1/2	2
43	8040150-102	PUNCH HOLDER	1
44	23A0516C0308	SCREW-SSS 5/16-18X3/8	2
45	8040110-800	CAP	1
46	18A0516X1102	PIN-SPRING 5/16X1-1/2	4
47	20A0516C1102	SCREW-SHCS 5/16-18X1-1/2	4
48	23A0516C0508	SCREW-SSS 5/16-18X5/8	2
52	8030120-801	HANDLE GRIP	1
OPTIONAL	8140150-370	DIE HOLDER ASSY A 1-1/4" BORE	
OPTIONAL	8240150-270	DIE HOLDER ASSY B 2-1/8" BORE	
OPTIONAL	8340150-270	DIE HOLDER ASSY D 3-3/4" BORE	
OPTIONAL	8440150-270	DIE HOLDER ASSY E 4-3/4" BORE	

### SERIES 901 - SINGLE STATION PUNCHES & DIES

**DIE HOLDER ASSEMBLIES** - The die holder is mounted on No. 2 Di-Acro punch press and is available in sizes to accommodate the five die styles. **Die holder 'C' will utilize dies with a smaller O.D. if fitted with the proper adapter.**

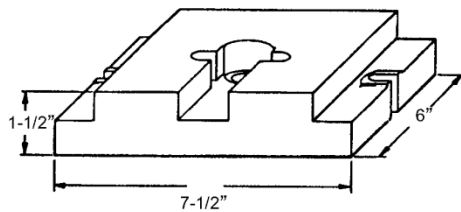

901 SERIES DIE HOLDER

DIE HOLDER STYLE	CAT. NO.	BORE IN HOLDER	ACCOMMODATES DIE STYLE
A	8140150-270	1 1/4"	A
B	8240150-270	2 1/8"	B
C	8040150-270	2 3/4"	C
D	8340150-270	3 3/4"	D
E	8440150-270	4 3/4"	E

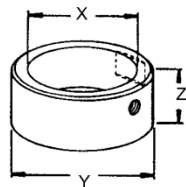

ADAPTER

### DIE ADAPTERS

ADAPTER STYLE	CAT. NO.	X	Y	Z	FITS DIE HOLDER
A	8040150-375	1 1/4"	2 3/4"	1 5/32"	C
B	8000150-375	2 1/8"	2 3/4"	1 5/32"	C

### PUNCH HOLDERS

STYLE	CAT. NO.
1"	8040150-102



# STANDARD SHAPED SERIES

Rectangle -300



Square -200



Round -000



Single D -400



Oblong -550



Oblong  
Center Radius -500



Hexagon -650



# COMMON SHAPED SERIES

Elipse -100



Lattice Bar -800



RS-232 -180



RS-232  
with slots -190



Keyhole -950



Double Keyhole  
with End Radii -120



Keyhole with  
End Radius -110



Corner  
Radius -170



Jail Bar -195



Teardrop -130



Hotdog -140



Elongated D -150



Gumdrop -160



# COMMON SHAPED SERIES

Pentagon -210



Heptagon -220



Octagon -230



Decagon -240



Rhombus -250



Rhomboid -260



Trapezoid -270



Trapezium -280



Equilateral  
Triangle -290



Isosceles  
Triangle -295



Right  
Triangle -310



Scalene  
Triangle -320



Point Star -330

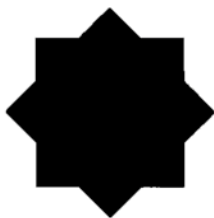

L-Shape -340



U-Shape -350



I-Shape -360



Cutler-Hammer™  
-370



General Electric™  
-380



Square D,  
Westinghouse™  
-390



Allen Bradley,  
Clark, General Electric  
Westinghouse™ -395



## OPTIONAL STAND

**PART NUMBER 8031110-900**  
**STAND DIMENSIONS - 28" WIDE, 15" DEEP, 33-1/4" HIGH**

**CALL DI-ACRO FOR PRICE AND AVAILABILITY**



Fasteners needed to attach Punch to the stand are the following:  
*(Fasteners to attach stand to floor are not included.)*

PART NUMBER	DESCRIPTION	QTY
21A0102C3000	SCREW-HHCS 1/2-13X3	4
61X0102	WASHER-FLAT 1/2	4
30X0102C	NUT-FULL 1/2-13	4

## **Warranty & Limitation of Liability**

Defective parts, of a product manufactured by DI-ACRO, will be replaced or repaired at no charge for twelve (12) months following delivery to the original purchaser. Labor is included for the first 90 days. This warranty becomes void when products have not been used according to instructions furnished by DI-ACRO, nor does it cover any altered parts or unauthorized repairs. We cannot be responsible for the cost of repairs made or attempted outside of our factory. All other warranty claims are made FOB our plant, providing such items(s) is returned freight prepaid to our plant for examination.

This warranty does not apply to parts, components or systems not manufactured by DI-ACRO. These products are covered instead by the existing warranties, if any, of their manufacturers. Normal service items with a reasonable life expectancy of less than one year are warranted only to the extent of the reasonable life under normal use and service.

Authorization must be obtained from DI-ACRO before returning parts or equipment to the factory. DI-ACRO will satisfy this warranty by replacing the product or refunding the purchase price upon receipt, inspection and defect identification.

DI-ACRO's liability under this warranty shall not exceed the amount paid for the product.

**THIS IS DI-ACRO'S SOLE WARRANTY IN LIEU OF ALL OTHER WARRANTIES, EXPRESS OR IMPLIED, WHICH ARE HEREBY EXCLUDED, INCLUDING IN PARTICULAR ALL WARRANTIES OF MERCHANTABILITY, FITNESS OR ANY LOSS, DAMAGE OR EXPENSES DIRECTLY OR INDIRECTLY RELATED TO THE USE OF ITS PRODUCT OR FROM ANY OTHER CAUSE OR FOR CONSEQUENTIAL DAMAGES INCLUDING, WITHOUT LIMITATION, LOSS OF TIME AND LOSS OF PRODUCTION.**

**IT IS EXPRESSLY UNDERSTOOD THAT DI-ACRO IS NOT RESPONSIBLE FOR DAMAGE OR INJURY CAUSED TO OTHER PRODUCTS, MACHINERY, PROPERTY OR PERSONS BY REASON OF THE USE OF ITS PRODUCTS.**



579 Schommer Dr - Ste C

Hudson, WI 54016

Phone: 651.342.1756

**Email: [info@diacro.com](mailto:info@diacro.com)**