



#1 POWER OPERATED NOTCHER



Di-Acro®

METAL FABRICATION EQUIPMENT

579 SCHOMMER DR - STE C

HUDSON, WI 54016

(651) 342-1756 (P)

DISCLAIMER

DI-ACRO by supplying this manual is not liable for any indirect, incidental, or consequential damages or injuries sustained or incurred in connection with using the information in any way contained herein.

DI-ACRO accepts no responsibility or liability resulting from attempts to use this information.

DI-ACRO does not vouch for or warrant the accuracy, completeness or usefulness of any information contained herein.

WIRING

Cost includes wiring for either of the following standard electrical systems.

110 or 220 volt single phase

220 or 440 volt three phase

Hook up lead-in wires and switch Motor on to check the direction of Flywheel. It should operate in a counter-clockwise direction as indicated by the **arrow**.

If the lead-in wires have been incorrectly hooked up, Tripping Mechanism will fail to operate. To remedy this, simply reverse any two lead-in wires.

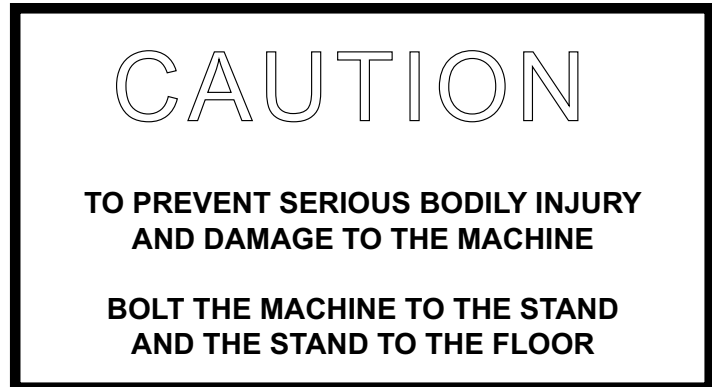

SETUP PROCEDURE

POWER NOTCHER

Except for wiring, the power operated Di-Acro Notcher is delivered ready for operation. To set up, simply hook up wiring, adjust Gauges for the proper size notch and machine is ready for production.

Smooth, even notches can be cut in all types of ductile material with the Di-Acro Notcher. It eliminates the high cost of special dies required for each different notching operation and does away with time wasted in punch press setup—you simply adjust the Material Gauge and you're ready for production.

Both power and hand operated models of this precision machine are available. They are equally useful in the experimental shop or on the production line.

Adjustable gauges are used to locate a notch of any dimension at the corner of a sheet of material or at any position along the edge of the sheet. Notches greater or less than 90 degrees can be obtained in two operations and many straight shearing operations can also be performed. The hardened and ground Triangular Ram used in the Di-Acro Notcher will provide years of continuous, trouble-free performance and assure a clean cut free from rough edges or burr.

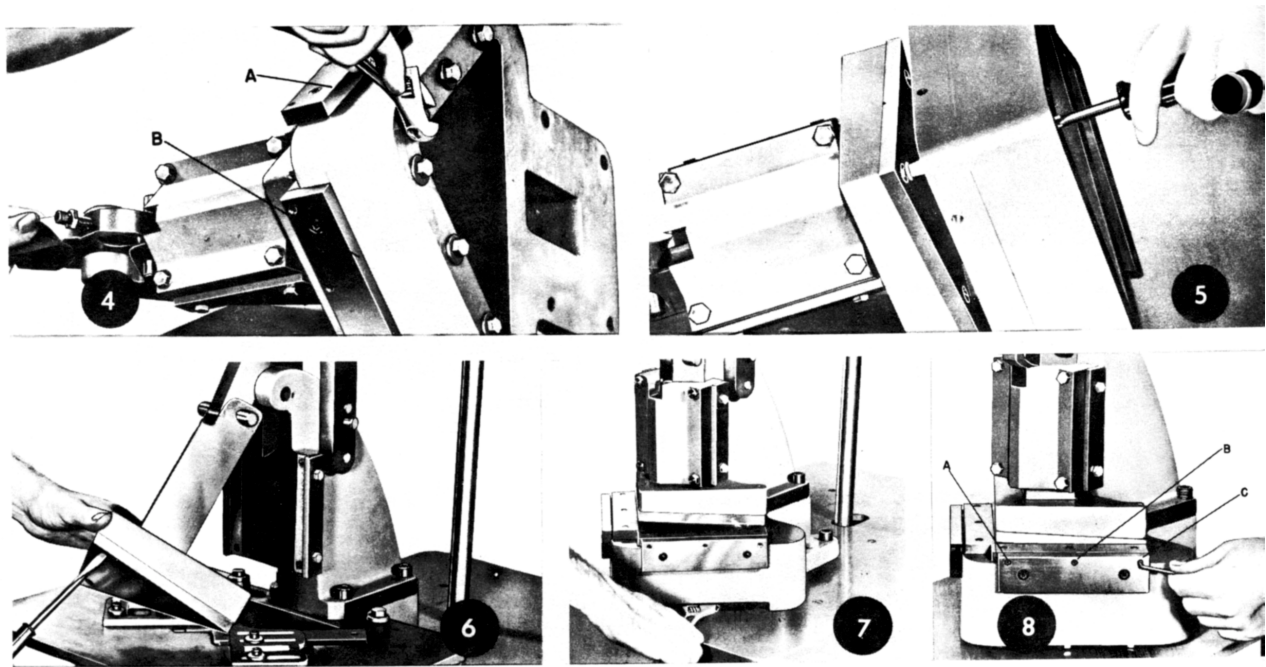

TO REMOVE BLADES

POWER NOTCHER—Because the Notcher unit is bolted to the power cabinet and has a Connecting Rod attached to it, it would be impractical to disassemble and turn the Notcher on its side. However, the upper Notching Blade can be removed either by reaching up through the material chute and removing the screws or by removing the Ram Cap* and tilting the Ram outward so that the screws can be reached (photo 6).

***CAUTION:** If Ram Cap is removed, make sure Shims between Ram and Ram Cap are replaced and Ram remains grit and dust free or it will be impossible to obtain proper alignment of the Notcher Blades.

To remove the two lower Notching Blades, remove the six bolts located below the Notcher Base (photo 7). Before replacing, carefully read instructions below on aligning lower Notching Blades.

ALIGNING LOWER NOTCHING BLADES

Alignment of lower Notching Blades on the power operated Di-Acro Notcher can be made by removing work table and adjusting set screws A, B and C (photo 8).

To test for exact alignment, insert a piece of paper and notch by hand. If Notcher fails to make a clean even cut at all points, adjust lower Blades accordingly.

STANDARD EQUIPMENT INCLUDES

1/2 H.P. Motor and all electrical equipment
12x18 inch work table, cast and precision ground
Adjustable Material Gauges
Tool Steel Notching Blades

SPECIFICATIONS AND CAPACITIES

DI-ACRO POWER NOTCHER	
Maximum 90 Degree Notch	6"X 6"
Rated Capacity	5 tons
Weight of Flywheel	85 lbs.
Stroke Per Minuter	180
Standard Motor (Optional)	1750 RPM
110-220 Volt AC Single Phase	1/2 HP
220-440 Volt AC Three Phase	1/2 HP
Operating Height	40"
Floor Space	17" X 28"
Net Weight	490 lbs.

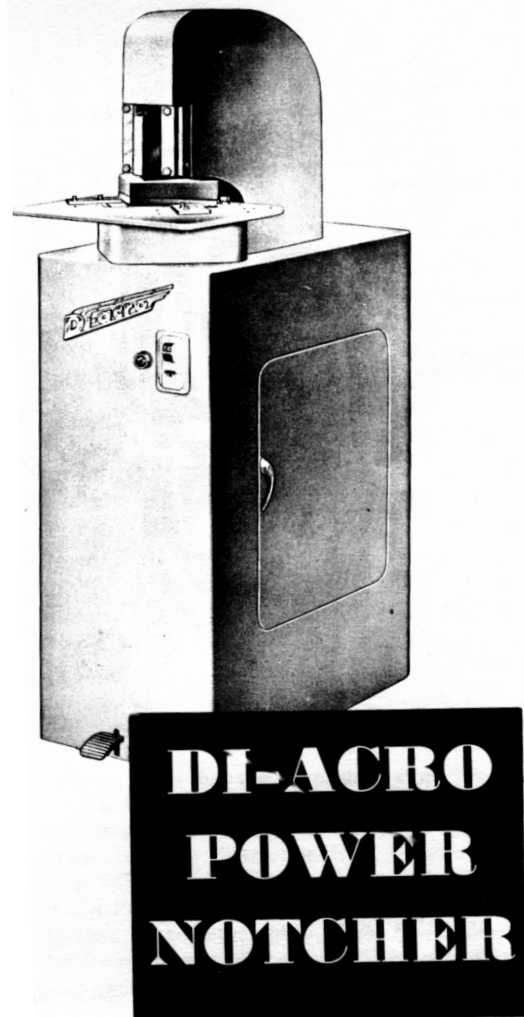

The Di-Acro Power Notcher is a complete Notching machine ready to operate with minimum set-up time. Because of the saving it affords in set-up time alone, it has proved indispensable in plants, which previously performed notching operations with special dies and heavy presses.

The heavy presses can be released for other operations and the cost of expensive notching dies eliminated. While maximum capacity of the Di-Acro Power Notcher is a 6 x 6 inch notch, in 16 gauge mild sheet steel, the minutest of notches can be made by adjusting the

material gauges. Precision construction of the Di-Acro Power Notcher includes a Triangular Ram, hardened and precision ground, which provides positive control of the Shearing Blades thereby assuring a clean cut in all shearable materials.

With Flywheel, Clutch, Motor and other operating parts housed in a sturdy welded steel cabinet, danger from exposed moving parts is eliminated and greater work visibility is provided the operator.

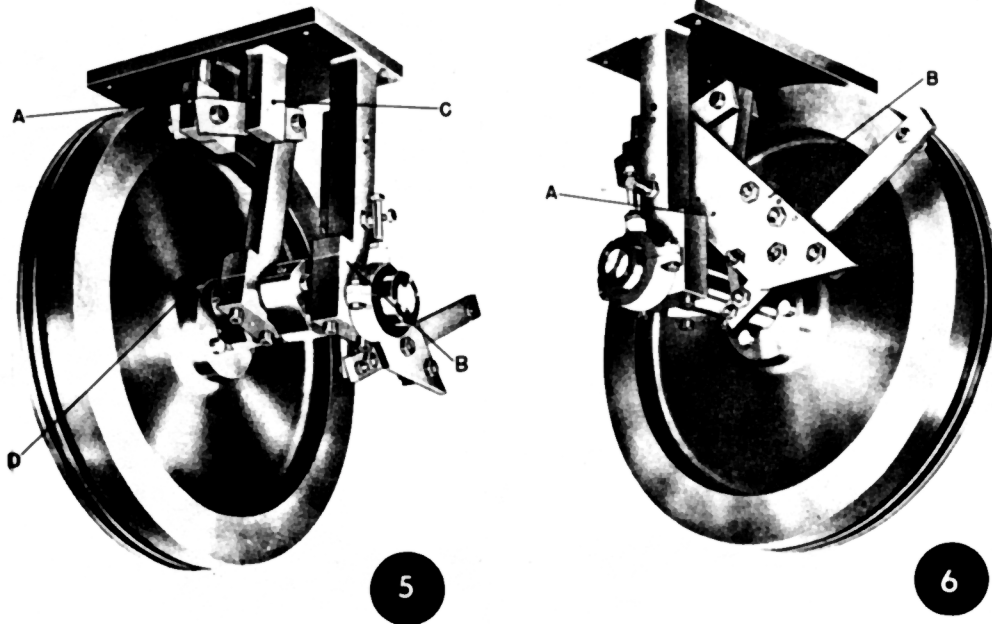

The driving mechanism on the power model should be lubricated periodically. Provision is made for lubrication in the following places:

Connecting Rod Bearing A (photo 5)

Crankshaft Bearing Block B, right and left (photo 5).

Rocker Support Arms C, right and left (photo 5).

Connecting Arm Assembly D, right and left (photo 5).

Sleeve Bearings in Motor.

Lubricate Clutch Release Lever A-B (photo 6) before each production run to insure instantaneous response.

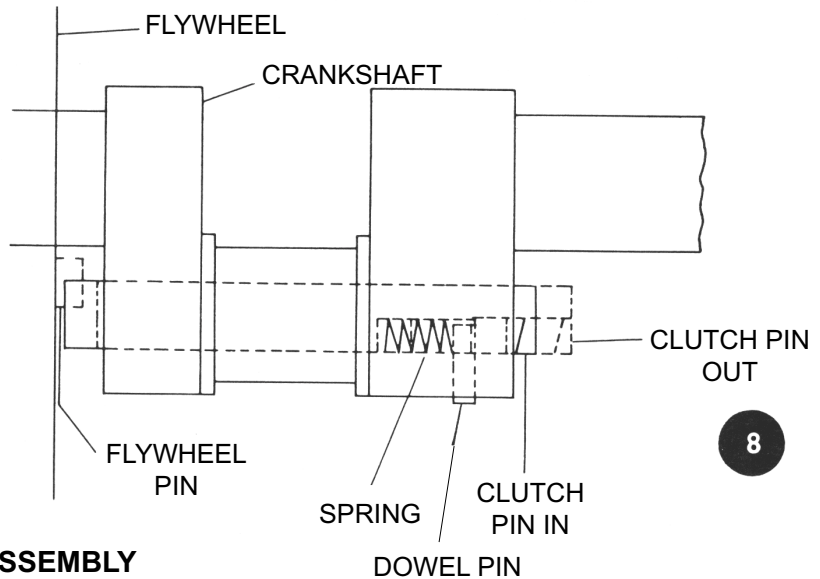
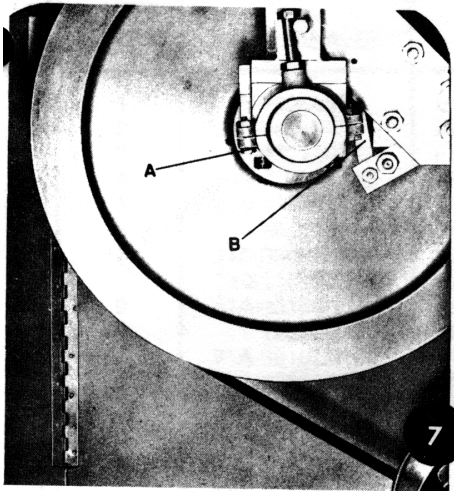

TROUBLE SHOOTING IN CLUTCH ASSEMBLY

BRAKE ADJUSTMENT

The Brake on the Crankshaft has been pre-set to stop “on center” at the end of each operating cycle. After continuous use, the Crankshaft may tend to go over center causing the machine to repeat its operating cycle or stop short of it thus producing a clicking sound. * This indicates that the Brake needs to be adjusted

Correct adjustment of the Brake can be made by either tightening or loosening Bolts A and B (photo 7) so that the Crankshaft stops “on center”. If the Brake is set too tight, the Crankshaft will stop before completing its cycle, failing to fully disengage Clutch Pin from Flywheel Pins. This will cause the Clutch Pin to strike the Flywheel Pins and over a period of time cause distortion. On the other hand, if the Brake Band is too loose, the punching cycle will repeat itself and may cause work damage.

***NOTE: Any binding in the Ram will act the same as the brake being set too tight. To check, disconnect connecting arm and move Ram up and down to see if it operates freely.**

BINDING CLUTCH PIN

When the Clutch Pin does not fully engage or disengage during each operating cycle, a continuous clicking sound will be heard as it strikes the edge of the Flywheel Pins.

A Binding Clutch Pin may be caused by either of the following reasons. It should be remedied before it causes additional damage.

A. CHECK SPRING TENSION—A special spring located inside the Clutch Pin (diagram 8) forces the Clutch Pin against the Flywheel Pins when the Trip Mechanism is released. If this spring becomes weakened, it allows the Clutch Pin to partially engage. Result—possible distortion and binding.

B. CHECK ENDS OF CLUTCH PIN—If the Clutch Pin has been defaced or shows signs of excessive wear, it’s a good indication that it has not been fully engaging or disengaging. Check spring tension and brake adjustment before replacing this Pin to eliminate any further clicking and damage to the Clutch Assembly.

HEAD ASSEMBLY 035-1305701

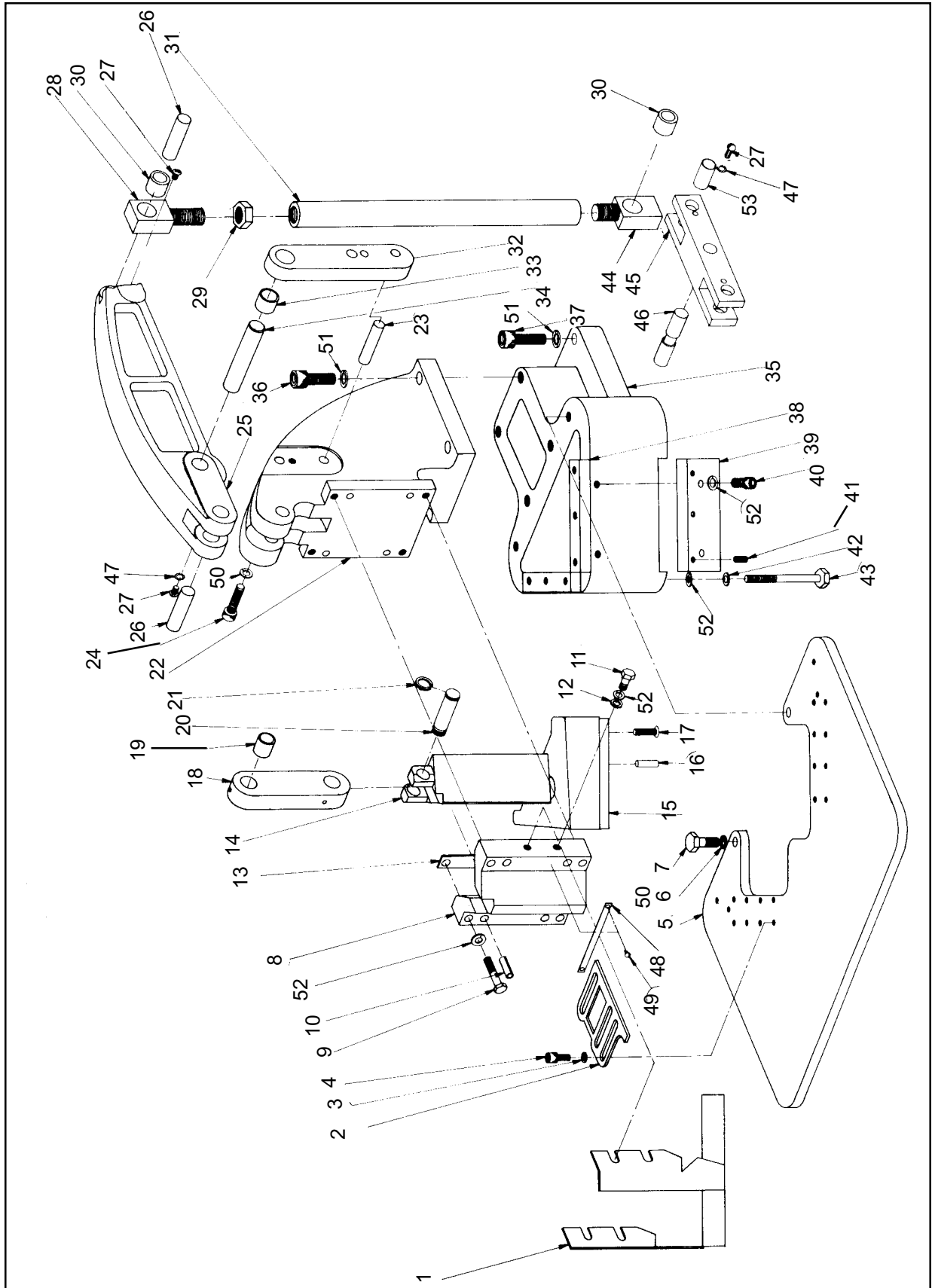

Item No.	Part No.	Description	Qty Used
1	030-1106099	Guard Assy	1
2	030-1405013	Protractor Gauge	2
3	61X0104	Flat Washer	4
4	20A0104C0508	Socket Head Cap Screw	4
5	030-1105012	Table	1
6	61X0308C1332	Flat Washer	2
7	21A0308C1000	Hex Head Cap Screw	2
8	040-1108006	Cap	1
9	21A0516C1508	Hex Head Cap Screw	4
10	1203102	Spring Pin	4
11	21A0516C0102	Hex Head Cap Screw	4
12	61X0308-0104	Flat Washer	4
13	030-5701017	Shim	2
	030-5701018	Shim	2
	030-5701019	Shim	2
	030-5701020	Shim	2
14	030-1213003	Ram Wldmt	1
15	030-1209009	Upper Blade	1
16	1203101	Dowel Pin	1
17	22C0104C1000	Flat Head Mach Screw	3
18	035-1201078	Ram Link	1
19	3104102	Brg.	2
20	060-1203003	Cam Roller Pin	1
21	4705101	Ret Ring	2
22	035-1102002	Upper Casting	1
23	1203177	Dowel Pin	4
24	20A0308C1102	Socket Head Cap Screw	2
25	035-1215075	Power Arm	1
26	035-1203074	Power Arm Pin	2
27	22D0104C0308	Truss Head Mach Screw	10
28	035-1201051	Rod End	1
29	31X0304F	Jam Nut	1
30	3104101	Brg.	2
31	035-1201050	Connecting Rod	1
32	035-1110076	Power Arm Support	2
33	3104103	Brg.	2
34	035-1203077	Pin	1
35	035-1101001	Base	1
36	20A0102C1304	Socket Head Cap Screw	4
37	20A0102C1102	Socket Head Cap Screw	4
38	030-1209010	Lower Blade	2
39	030-1110011	Lower Blade Support	2
40	20A0516C0508	Socket Head Cap Screw	4
41	23A0104C0102	Socket Set Screw	6
42	4901106	Flat Washer	6
43	21A0516C3102	Hex Head Cap Screw	6
44	035-1201053	Rod End	1
45	035-1215071	Rocket Arm	1
46	035-1203070	Rocket Arm Pin	1
47	62X0104	Lock Washer	12
48	030-6503105	Instruction Plate	1
49	29AXX0X0108C	Drive Screw	2
50	62X0508	Lock Washer	4
52	62X0516M	Lock Washer	18
53	346-1203028	Clamp Pin	2
	030-1202004	Cam (Hand Notcher Only)	1 (Not Shown)
	030-1208007	Long Handle Arm (Hand Notcher Only)	1 (Not Shown)
	156-1113005	Roller (Hand Notcher Only)	1 (Not Shown)
	030-1203020	Cam Pin (Han Notcher Only)	1 (Not Shown)

LOWER ASSEMBLY

035-1109702

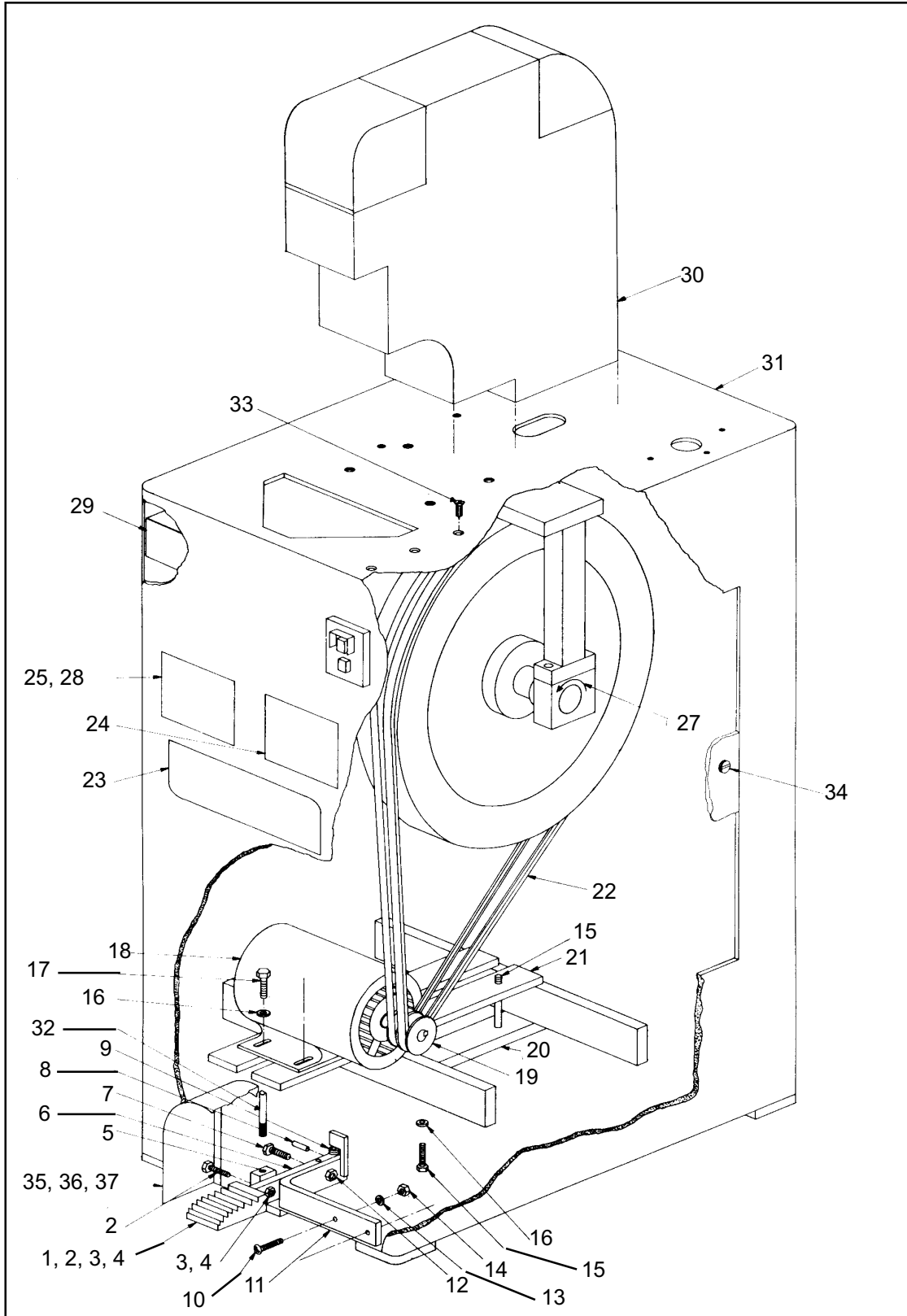

Item No.	Part No.	Description	Qty
1	035-1308003	Foot Pedal	1
2	21A0516C1104	Hex Head Cap Screw	1
3	62X0516M	Lock Washer	1
4	31X0516C	Jam Nut	1
5	250-1301064	Foot Pedal Link Block	1
6	035-1325033	Pedal Arm	1
7	21A0308C1104	Hex Head Cap Screw	1
8	1203135	Spring Pin	1
9	5102103	Spring	1
10	22D0104C0508	Truss Head Mach Screw	2
11	035-1301100	Pedal Bkt Widmt	1
12	31X0308C	Jam Nut	1
13	61X0104	Flat Washer	2
14	31X0104C	Jam Nut	2
15	21A0516C3000	Hex Head Cap Screw	4
16	4901106	Flat Washer	4
17	21A0516C0508	Hex Head Cap Screw	4
19	1205089	Sheave	1
20	035-1110080	Motor Mount Clamp	2
21	035-1110079	Motor Mount	2
22	4401001	V-Belt	1
23	068-6502001	Name Plate	1
24	035-6503001	Warning Plate	1
25	035-6501112	Name Plate	1
27	032-6503018	Arrow Plate	1
28	29AXX0X0108C	Drive Screw	10
29	035-1109701	Chute Assy	1
30	035-1106003	Guard	1
31	035-1109013	Cabinet	1
32	035-1301099	Foot Pedal Link Rod	1
33	22C0104C0508	Flat Head Mach Screw	3
34	4701147	Panel Screw	2
35	6999922	Rubber Extension	1
36	035-1106022	Foot Pedal Guard	1
37	20AXX10C0308	Socket Head Cap Screw	4

DRIVE GP 035-1204701

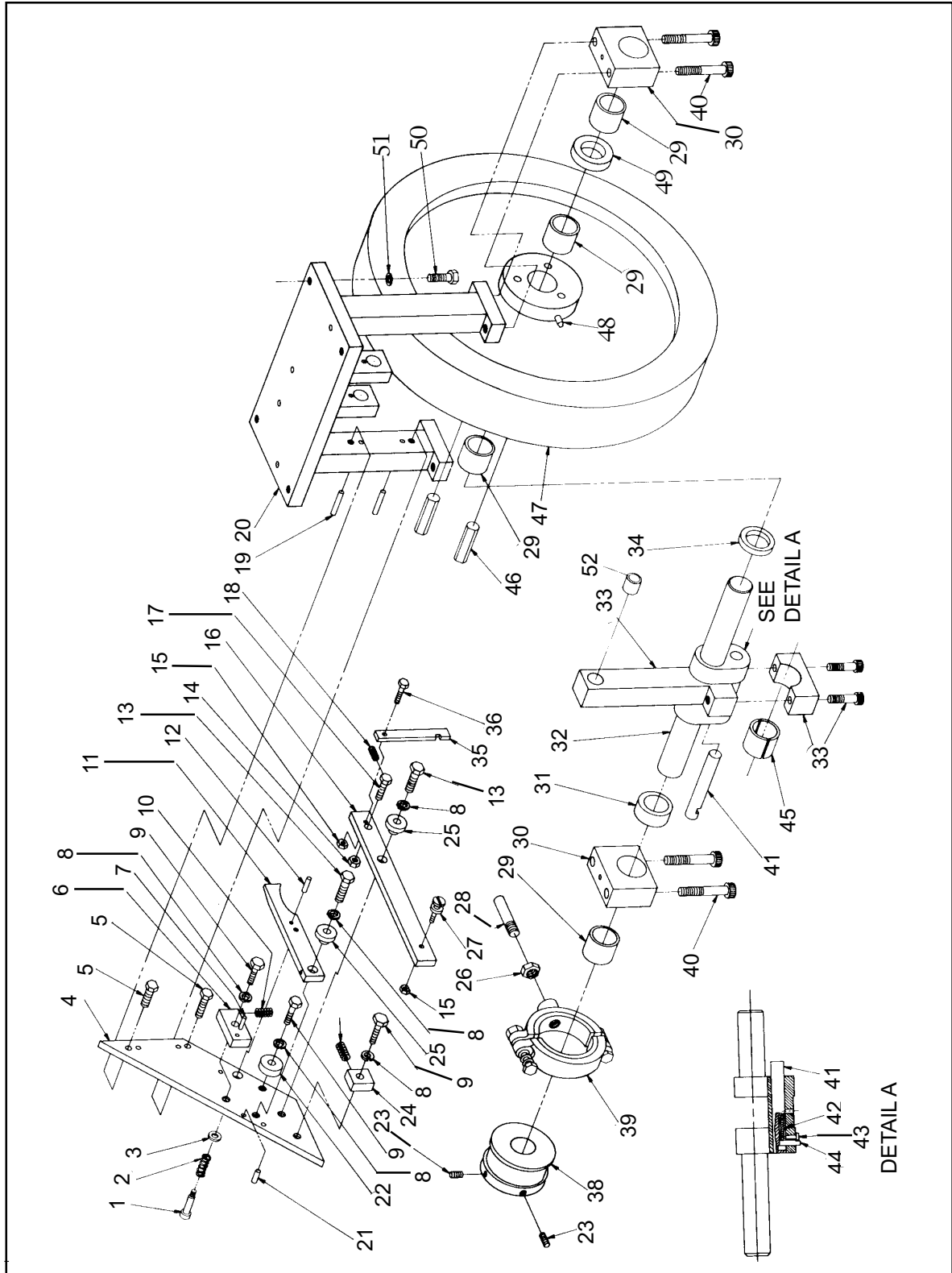

Item No.	Part No.	Description	Qty Used
1	25X0516C1104	Shoulder Screw	1
2	5102101	Spring	1
3	61X0104	Flat Washer	1
4	035-1110090	Trip Mount	1
5	21A0516C1000	Hex Head Cap Screw	2
6	035-1301091	Spring Container	1
7	1203134	Spring Pin	1
8	62X0508	Lock Washer	5
9	21A0308C1000	Hex Head Cap Screw	3
0	5102102	Spring	1
11	035-1301096	Clutch Release Lever	1
12	1203105	Dowel Pin	1
13	21A0308C1104	Hex Head Cap Screw	2
14	31X0308C	Jam Nut	1
15	31X0104C	Jam Nut	2
16	035-1301095	Trip Lever	1
17	035-1301097	Spring Bolt	1
18	120-5102022	Spring	1
19	1203178	Dowel Pin	2
20	035-1110065	Crankshaft Support	1
21	1203192	Dowel Pin	1
22	035-1301092	Spacer	1
2	23A0516C1000	Socket Set Screw	2
24	035-1206083	Spring Container	1
25	250-1108069	Link Spacer Sleeve	2
26	30X0102F	Hex Nut	1
27	250-1301062	Foot Pedal Pivot Stud	1
28	056-1207056	Brake Rod	1
29	3104104	Bearing	4
30	035-1110067	Crankshaft Bearing Block	2
31	035-1201069	Crankshaft Trip Spacer	1
32	035-1201060	Crankshaft	1
33	035-1201702	Connecting Arm Assy	1
34	035-1206085	Clutch Spring	1
35	035-1301094	Safety Link	1
36	21A0104C1000H	Hex Head Cap Screw	1
37	510211	Spring	1
38	270-1207054	Brake Collar	1
39	270-1207710	Brake Show Assy	1
40	20A0308C3000	Socket Head Cap Screw	4
41	035-1206089	Clutch Dog	1
42	035-5102082	Spring	1
43	22FXX06C0104	Binder Head Mach Screw	1
44	035-1203066	Clutch Dog Pin	1
45	035-3106055	Bearing Insert	1
46	035-1206084	Drive Pin	3
47	035-1204086	Flywheel	1
48	411001	Oil Hole Cover	1
49	035-1201087	Flywheel Spacer	1
50	21A0308C1104	Hex Head Cap Screw	4
51	4901159	Flat Washer	4
52	3104101	Bearing	1

BRAKE SHOE ASSEMBLY 270-1207710

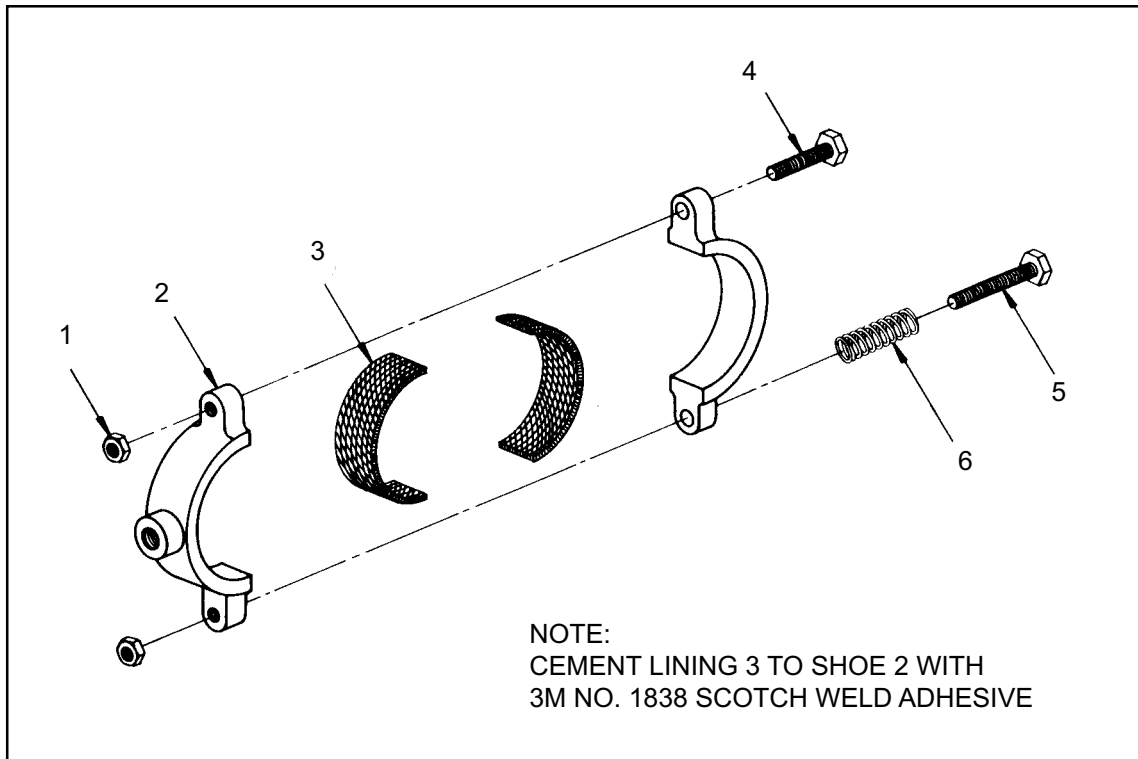

Item No.	Part No.	Description	Qty Used
1	31X0516C	Jam Nut	2
2	270-1207055	Brake Shoe	1
3	270-1207001	Brake Lining	2
4	4701137	Hex Head Cap Screw	1
5	4701112	Hex Head Cap Screw	1
6	512110	Spring	1

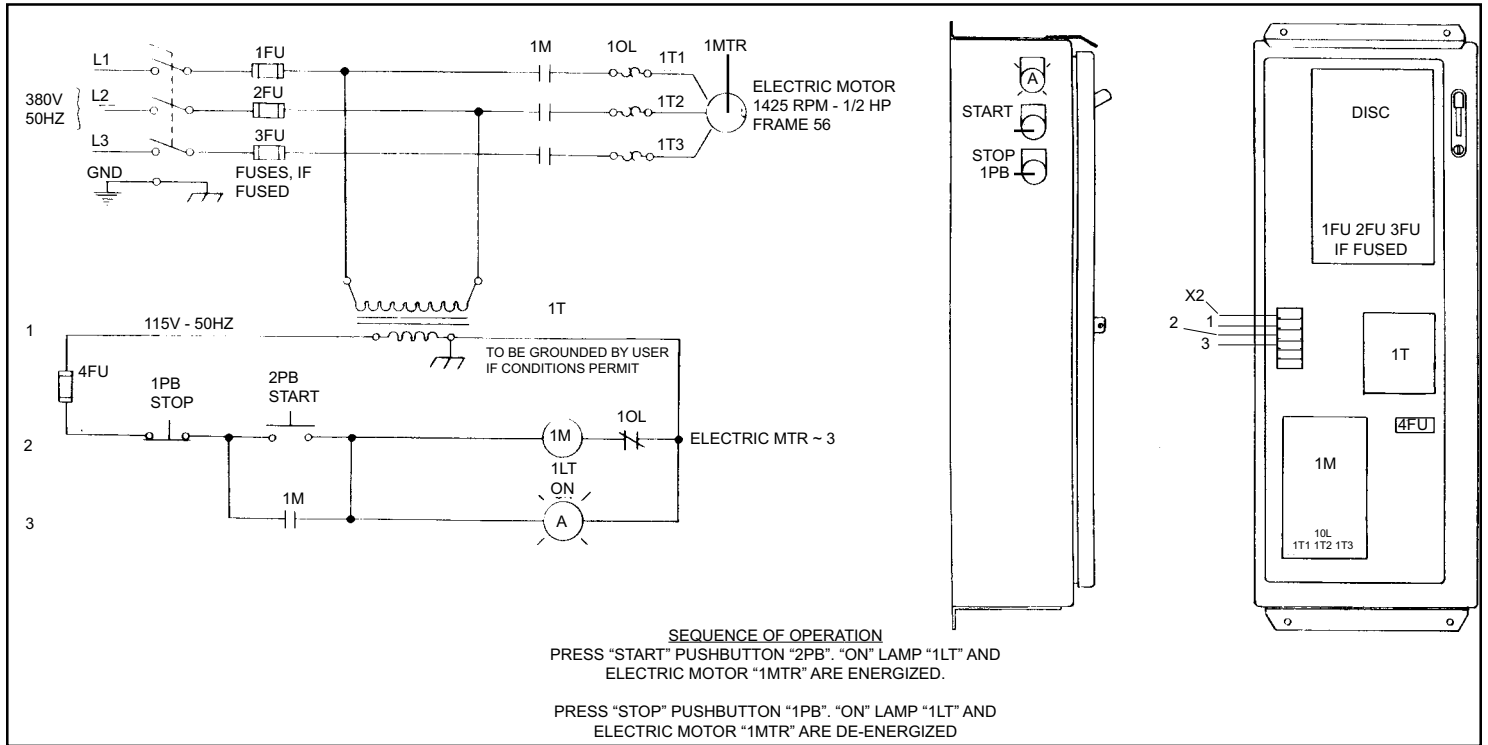

Sym	Part No.	Description	Qty
		Operating Mechanism ~ GE #343L543G3	1
	3308115	Terminal Block ~ Curtis #2PSWTC	3
	065-3308001	Track ~ Curtis SW-96 (5" Length)	1
2PB	3332017	Legend Plate Start Furnas #D11804003	1
2PB	3303088	Contact Block NO ~ Furnas #BJK	1
2PB	3303058	Pushbutton Operator ~ Furnas #BJP2	1
1PB	3332089	Legend Plate - Stop - Furnas #D11804004	1
1PB	3303089	Contact Block NC ~ Furnas BJJ	1
1PB	3303059	Push Button Operator ~ Furnas BJR2	1
1LT	3332015	Legend Plate - On - Furnas D11804013	1
1LT	3303050	Amber Lens ~ Furnas BJ4G	1
1LT	3302013	Pilot Light ~ Furnas BJL1	1
4FU	3318051	Fuse ~ Buss FNM1/2	1
1T	3311043	Transformer Micron BX150MBRTW13-XK	1
10L	3323018	Heater Element ~ Furnas #H-15	3
1M		Starter ~ Furnas 14CF32AA	1
1-3FU	3318014	Fuse Buss #FRS 1-6/10	3
1-3FU		Fuse Clip ~ GE THMC 3100	1
DISC		Disconnect Switch ~ GE THMS 31 Model 2	1
		Enclosure Panel	1

ELECTRIC DIAGRAM 032-911001

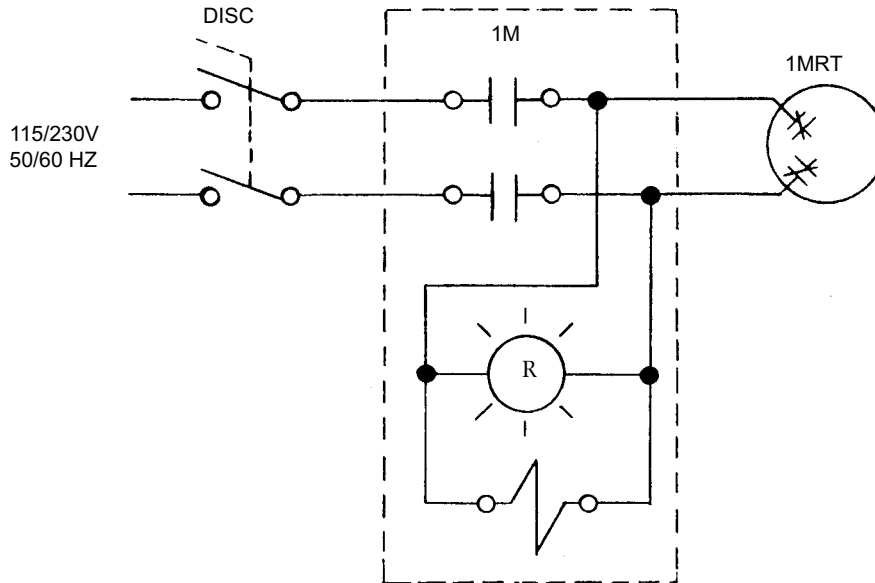

Sym	Part No.	Description	Qty
1MTR	3301020	Motor	1
1M	3304043	Manual Starter Furnas	1
1M	3304042	Manual Starter Furnas	1
DISC	3331013	Disconnect Switch	1