

# ***DI-ACRO #24 SLIP ROLLER INSTRUCTION MANUAL***



980 West Lakewood Ave. • Box 466 • Lake City, MN 55041  
[www.acrotechinc.com](http://www.acrotechinc.com)



Fabrication Equipment Division  
[www.diacro.com](http://www.diacro.com)

[acrotech@acrotechinc.com](mailto:acrotech@acrotechinc.com) • 800-345-0583 • Fax: 651-345-3759

## **TABLE OF CONTENTS**

<b>A.</b>	<b>SAFETY INFORMATION</b>	<b>PG. 3</b>
<b>B.</b>	<b>TECHNICAL DATA</b>	<b>PG. 3</b>
<b>C.</b>	<b>FORMING CIRCLES</b>	<b>PG. 4</b>
<b>D.</b>	<b>SHAPING METAL</b>	<b>PG. 5</b>
<b>E.</b>	<b>EXPLODED ASSEMBLY</b>	<b>PG. 6-9</b>
<b>F.</b>	<b>OPTIONAL STAND</b>	<b>PG. 10</b>
<b>G.</b>	<b>WARRANTY &amp; LIMITATION OF LIABILITY</b>	<b>PG. 11</b>

## A. Safety Instructions



**Before roller is set up for operation, mount on work bench or stand\*.**

**\*IF ROLLER IS MOUNTED ON ITS OWN STAND, SECURE STAND TO FLOOR**

## B. Technical Data

### HAND OPERATED ROLLERS

<b>DI-ACRO ROLLERS</b>	<b>No. 12</b>	<b>No. 24</b>
Maximum Forming Width	12"	24"
Material Capacity - Steel	16 ga.	20 ga.
Diameter or Rolls	2"	2"
Minimum Radius	1"	1"
Max. Depth of Box or Pan	No Limit	No Limit
Floor Space (On Stand)	15x18.5	15x40
Shipping Weight	115	170
Stand Weight Lbs.	86	108

### FRONT AND REAR ADJUSTMENT SCREWS

The four adjusting screws (two located in the front and two located in the rear) have been built into the left and right side frames. The two front adjusting screws enable the operator to raise or lower the pinch roll, so that the correct gap between the upper and lower pinch roll may be obtained to feed the desire stock into the machine. The left and right rear adjusting screws assist the operation in raising or lower the idler roll which determines the degree of bend in the stock that is being fed through the machine. The right and left side frames are each equipped with a scale to aid the operator in determining the correct angle of bend in the stock.

## C. FORMING CIRCLES

### HOW TO FORM CIRCLES IN JUST TWO PASSES.

LENGTH OF MATERIAL-necessary to form the desired size circle is the first consideration in circle forming. To determine approximate length of material needed-use the formula  $C = \pi D$ . C is circumference.  $\pi$  EQUALS 3.1417. D is diameter. For example, to find the length of material needed (C or Circumference) to form a circle 4" in diameter multiply 3.1417 by 4". Result-12.5667 is the circumference or approximate length of material needed. Cut a few pieces of material to this length for test forming. Material may have to be lengthened or shortened depending upon results of the test forming run.

TO ADJUST ROLLER-for material thickness loosen the thumb screws. Turn the adjusting screws to raise or lower the lower pinch roll. Insert the material between the rolls from the front of the machine and set rolls so the material fits tightly. Retighten the thumb screws and remove the material from between the rolls.

TO ADJUST THE ROLLER-for the diameter of circle to be formed; raise the idler roll by pulling the cam lever toward the operator until the idler roll seems to "fall into place". Loosen the thumb screws next to the rear adjusting screws on the back of the roller. Set the idler roll by turning the rear adjusting screws. After the idler roll has been set for the desired angle of bend, tighten the thumb screws.

NO EXACT FORMULA- can be followed when making this adjustment because material "springback" varies with the kind of material being formed. Only by test forming several pieces can the correct adjustments be obtained. Rolls must be adjusted exactly parallel or the material will spiral during the rolling process.

TO OPERATE ROLLER-after diameter adjustments have been made, insert material from front of roller and turn operating handle in a clockwise direction until about half of the material has passed through the rolls. Then, while feeding material, raise the idler roll. Continue turning until a half circle has been formed. It is important that you operate the roller while engaging the cam lever, for if the cam lever is engaged while the rolls are not turning, a noticeable flat spot or line will be formed across the width of the material.

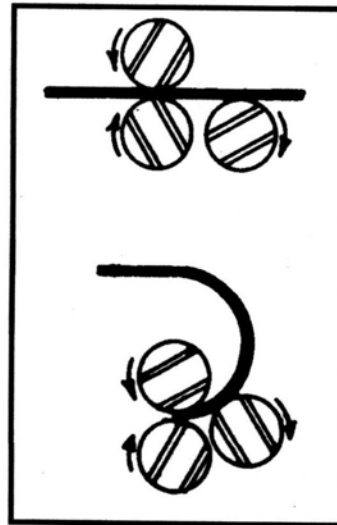

AFTER HALF CIRCLE-has been formed, re-insert the formed end of the material into the roller (as illustrated) and turn operating handle in a clockwise direction to form a complete circle.



## D. SHAPING METAL

TO REMOVE THE FORMED PART-lift clamp handle and slide the support lever handle to the right. The upper pinch roll will rise. Slide the material off roll. If the material is not long enough or if the formed part is not the proper diameter, additional samples will have to be made. Thousands of identical parts can be precisely duplicated when proper adjustments of the roller have been made.

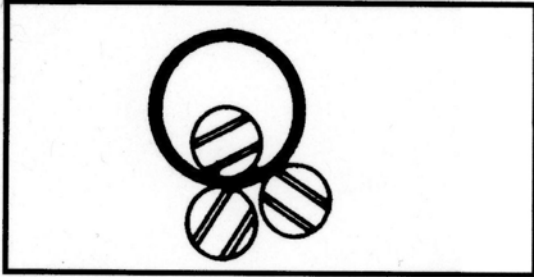

### REVERSE ROLLING

CIRCLES-the same diameter as the diameter of the rolls and slightly larger, can be formed with the Di-Acro Roller in just one pass. To make the adjustment for material thickness and to determine the length of material needed, see the instructions given under "How To Form Circles In Just Two Passes."

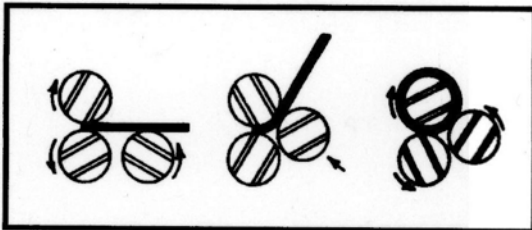

### BENDS CAN BE LOCATED AT ANY POINT IN METAL

TO OPERATE-insert material to be formed from the rear of the machine. Material should be inserted in the machine so that the rolls just "nip" the end of the material. Then, place the idler roll into operating position and operate machine so that the upper pinch roll rotates in a clockwise direction. If adjustments are correct and the material is the right length, a perfect circle is formed.

FLAT MATERIAL- can be rolled part way through the rolls and bent by raising the idler roll using the cam lever. Disengaging the cam lever lowers the idler roll, and the material again passes through the rolls without being bent. It is possible to form a wide variety of shapes with the Di-Acro Roller.

# **PARTS BREAKDOWN** **# 24 ROLLER**

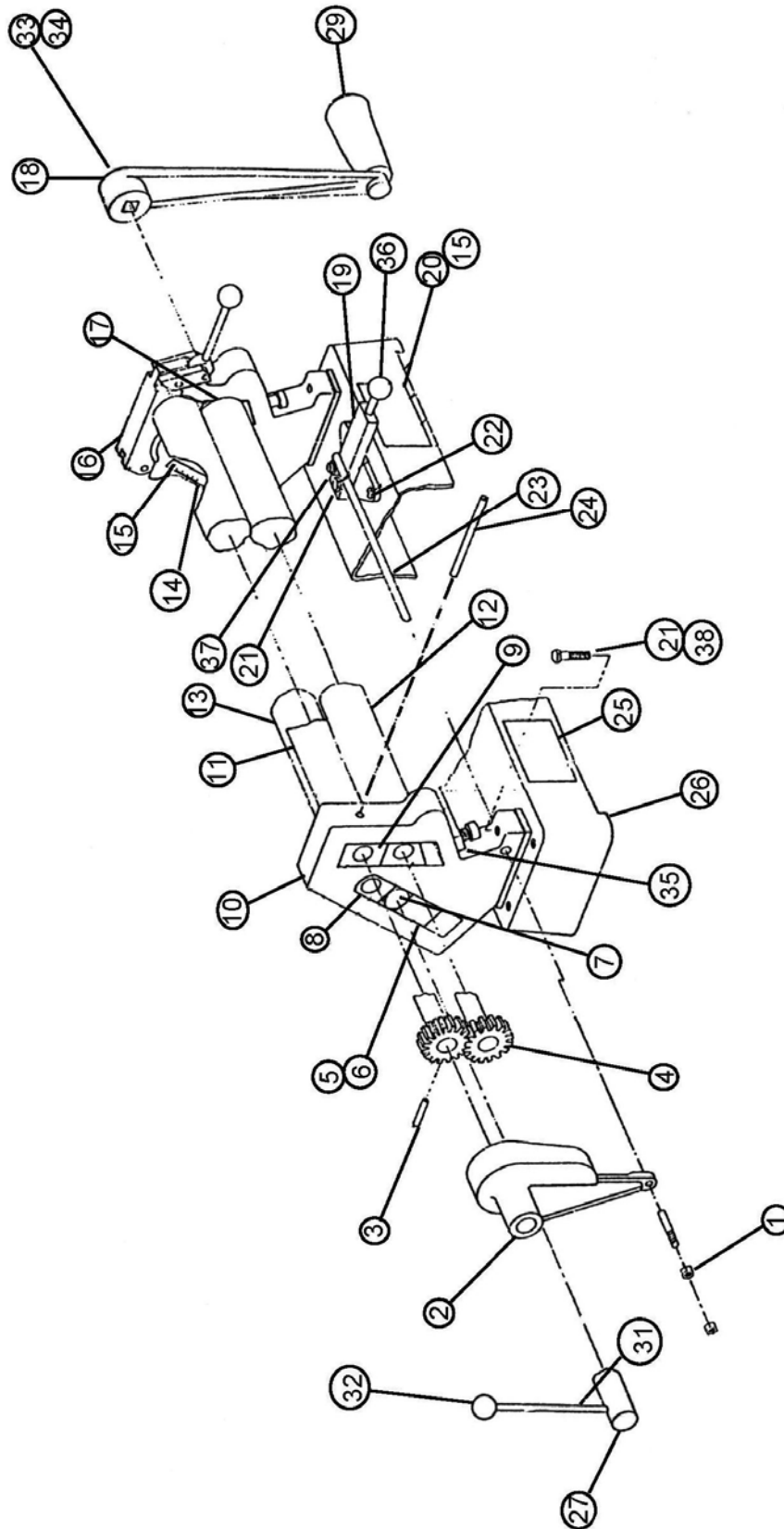

**#24 SLIP ROLLER  
PARTS LIST**

ITEM	PART NUMBER	DESCRIPTION	QTY
1	31X0516C	NUT-JAM 5/16-18	2
2	8421110-602	GEAR CAP	1
3	18A0104X1102	PIN-SPG 1/4 X1-1/2	2
4	8421390-103	GEARS	2
5	8421120-201	CAM BLOCK	2
6	22D0104C0102	SCREW-TRUSS HEAD 1/4-20X1/2	4
7	8100121-401	LOWER PINCH ROLL BOX-LH	1
8	8000121-400	IDLER ROLL BLOCK	2
9	8300121-401	PIVOT BLOCK	1
10	8000110-370	SIDE FRAME LH ASSY (SEE PAGE 8 FOR BREAKDOWN OF PARTS FOR LH SIDE FRAME)	1
11	8400121-401	UPPER PINCH ROLL	1
12	8440121-401	LOWER PINCH ROLL	1
13	8440121-400	IDLER ROLL	1
14	8410160-103	SCALE	2
15	3/16DRIVESCREW	DRIVE SCREW #2 X 3/16	6
16	8421110-370	SIDE FRAME RH ASSY (SEE PAGE 9 FOR BREAKDOWN OF PARTS FOR RH SIDE FRAME)	1
17	8000121-401	LOWER PINCH ROLL BOX RH	1
18	8421120-802	HANDLE ARM	1
19	8000111-004	PINCH ROLL SUPPORT LEVER	1
20	8030650-301	LABEL-PINCH POINT	1
21	21A0308C1102	SCREW-HEX HEAD 3/8-16X1-1/2	5
22	21A0308C0508	SCREW-HEX HEAD 3/8-16X5/8	1
23	8440111-004	ROD WELDMENT	1
24	8421120-301	LOCKING PIN	1
25	030-6503001	LABEL-CAUTION	1
26	440-1101001	BASE-24"	1
27	8441120-200	IDLER ROLL CAM	1
29	8120811-400	HANDLE	1
	25X308C2304	SCREW-SHLDR 3/8-16X2-3/4(NOT SHOWN HOLDS HANDLE ON)	1
31	421-1202009	IDLER CAM LEVER	1
32	8120810-700	KNOB	1
33	22D0516C0102	SCREW-TRUSS HEAD 5/16-16X1/2	1

**#24 SLIP ROLLER  
PARTS LIST  
CONTINUED**

ITEM	PART NUMBER	DESCRIPTION	QTY
34	8421111-000	FENDER WASHER 5/16X1-1/4	1
35	8410110-802	ADJUSTMENT SCREW STOP	1
36	8422811-400	HANDLE-PINCH ROLL	1
37	19A0308X1000	DOWEL PIN 3/8 X 1	1
38	30X0308C	NUT-FULL 3/8-16	1
39	31X0308C	NUT-JAM 3/8-16(NOT SHOWN) GOES ON ITEM 22	1
40	8150650-110	SERIAL TAG (NOT SHOWN GOES ON FRONT OF MACHINE BASE)	1

**SLIP ROLLER LEFT HAND SIDE  
PARTS LIST**

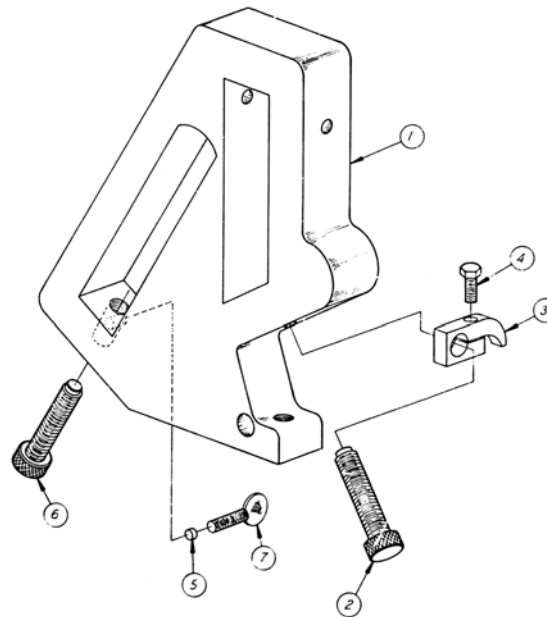

ITEM	PART NUMBER	DESCRIPTION	QTY
1	421-1103003	SIDE FRAME LH	1
2	8410470-102	FRONT ADJUSTMENT SCREW	1
3	8410110-802	ADJUSTMENT SCREW STOP	1
4	20A0104C0304	SCREW-SOC HEAD 1/4X3/4	1
5	8410110-803	SPACER	1
6	8000470-102	REAR ADJUSTMENT SCREW	1
7	28A0104C0102	SCREW-THUMB 1/4X1/2	1

**SLIP ROLLER RIGHT HAND SIDE  
PARTS LIST**

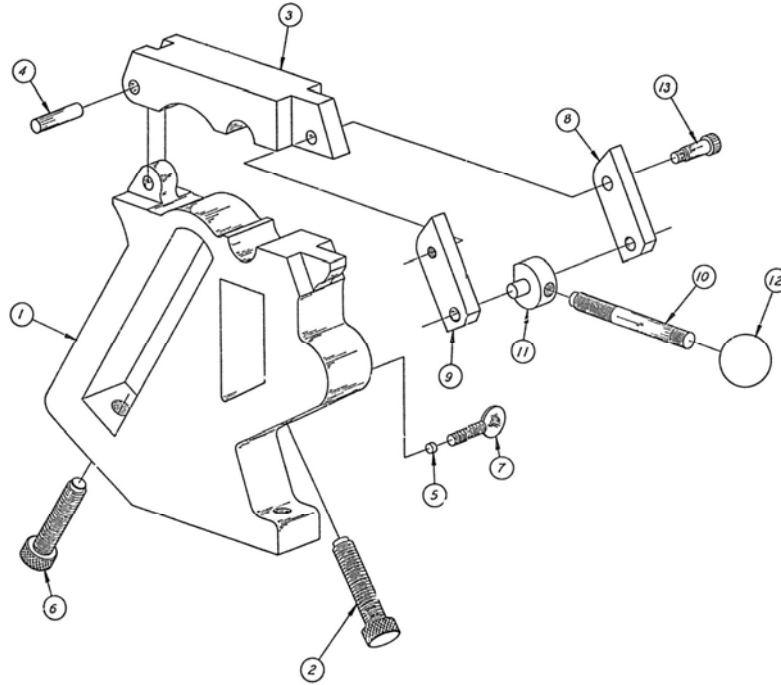

ITEM	PART NUMBER	DESCRIPTION	QTY
1	8421110-300	SIDE FRAME-RIGHT	1
2	8410470-102	FRONT ADJUSTMENT SCREW	1
3	8421111-001	CLAMP	1
4	19A0516X1104	PIN-DOWEL 5/16 X 1-1/4	1
5	8410110-803	SPACER	2
6	8000470-102	ADJUSTING SCREW-REAR	1
7	28A0104C0102	SCREW-THUMB 1/4X1/2	2
8	8000110-303	CLAMP LOCK LINK R	1
9	8421110-303	CLAMP LOCK LINK L	1
10	8421470-102	CLAMP STUD	1
11	8421120-203	CLAMP LOCK CAM	1
12	8120810-600	KNOB	1
13	25X0516X0304	SCREW-SHOULDER 5/16X3/4	1

**E. OPTIONAL STAND PART NUMBER 8346110-900  
 STAND DIMENSIONS ARE:  
 38" WIDE, 15" DEEP, 33-1/4" HIGH**

**CALL ACROTECH FOR PRICE AND AVAILABILITY**

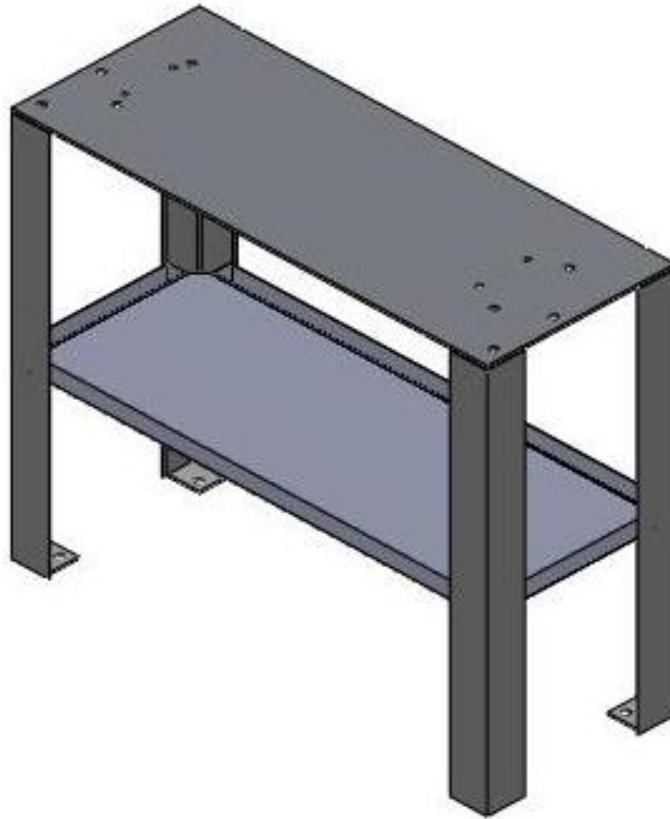

Fasteners needed to attach Roller to stand are the following:  
 Fasteners to attach stand to floor are not included.

PART NUMBER	DESCRIPTION	QTY
21A0102C3000	Screw-HHCS 1/2-20X3	4
61X0102	Washer-Flat 1/2	4
31X0102	Nut-Hex Jam 1/2-20	4

# Warranty & Limitation of Liability

Defective parts of a product manufactured by ACROTECH/DI-ACRO will be replaced or repaired at no charge for twelve (12) months following delivery to the original purchaser. Labor is included for the first 90 days. This warranty becomes void when products have not been used according to instructions furnished by ACROTECH/DI-ACRO, nor does it cover any altered parts or unauthorized repairs. We cannot be responsible for the cost of repairs made or attempted outside of our factory. All warranty claims are made FOB our plant, providing such item(s) is returned freight prepaid to our plant for examination.

This warranty does not apply to parts, components or systems not manufactured by ACROTECH/DI-ACRO. These products are covered instead by the existing warranties, if any, of their manufacturers. Normal service items with a reasonable life expectancy of less than one year are warranted only to the extent of the reasonable life under normal use and service.

Authorization must be obtained from ACROTECH/DI-ACRO before returning parts or equipment to the factory. ACROTECH/DI-ACRO will satisfy this warranty by replacing the product or refunding the purchase price upon receipt and inspection of the product.

ACROTECH/DI-ACRO's liability under this warranty shall not exceed the amount paid for the product.

**THIS IS ACROTECH/DI-ACRO'S SOLE WARRANTY IN LIEU OF ALL OTHER WARRANTIES, EXPRESS OR IMPLIED, WHICH ARE HEREBY EXCLUDED, INCLUDING IN PARTICULAR ALL WARRANTIES OF MERCHANTABILITY, FITNESS OR ANY LOSS, DAMAGE OR EXPENSES DIRECTLY OR INDIRECTLY RELATED TO THE USE OF ITS PRODUCT OR FROM ANY OTHER CAUSE OR FOR CONSEQUENTIAL DAMAGES INCLUDING, WITHOUT LIMITATION, LOSS OF TIME AND LOSS OF PRODUCTION.**

**IT IS EXPRESSLY UNDERSTOOD THAT ACROTECH IS NOT RESPONSIBLE FOR DAMAGE OR INJURY CAUSED TO OTHER PRODUCTS, MACHINERY, PROPERTY OR PERSONS BY REASON OF THE USE OF ITS PRODUCTS.**